



ALPHA  **SUPPLY**

IN STOCK | ON SITE | ON TIME

**ORDERING OF
HVAC MATERIALS
MADE EASY**

PRODUCT CATALOGUE - EDITION 2

Our mission is simple – To have your

HVAC Materials In Stock, On Site and On Time - Everytime

Since its inception, Alpha Supply has become the trusted supplier to many HVAC and Mechanical Services contractors across our great country. Alpha Supply is able to provide all installation materials for your HVAC project in one delivery.

Coming from a contracting background, we understand the demands of the industry and are focused on partnering with contractors to increase their project profitability through service, solutions and the ability to rely on a transparent supplier for all installation materials.

Our passion for the industry is evident, and this passion flows through the whole company culture.

**Alpha Supply has massive stocks
ready for your project.**

ORDERING OF HVAC MATERIALS MADE EASY



ALPHA  **SUPPLY**

IN STOCK | ON SITE | ON TIME

Alpha Supply Pty. Ltd.
51 Assembly Dr, Tullamarine VIC 3043
PO Box 132 Tullamarine VIC 3043
P: +61 (0) 3 9445 0848
F: +61 (0) 3 9445 0849
W: www.alphasupply.com.au
E: sales@alphasupply.com.au

CONTENTS

COPPER TUBE & FITTINGS	4
INSULATION	10
ZOOMLOCK BRAZE FREE FITTINGS	12
CONDENSATE REMOVAL	20
CONDENSER BRACKETS	32
BIGFOOT SYSTEMS	36
PIPE DUCTING	38
PIPE SUPPORTS	42
FASTENERS AND FIXINGS	48
GAS & PA SYSTEMS	70
QUICKZIP WIRE SUSPENSION SYSTEM	78
CABLE TRAY	82
FRAMO 80	84
SEALANTS AND ADHESIVES	86
VENTILATION	94
FIRE PROTECTION	102
ELECTRICAL	108
PPE & SAFETY	114
NITRO, OXY & ACETYLENE	118
TOOLS & MAINTENANCE EQUIPMENT	122
LASER MEASURERS & SITE STORAGE	146

COPPER TUBE & FITTINGS

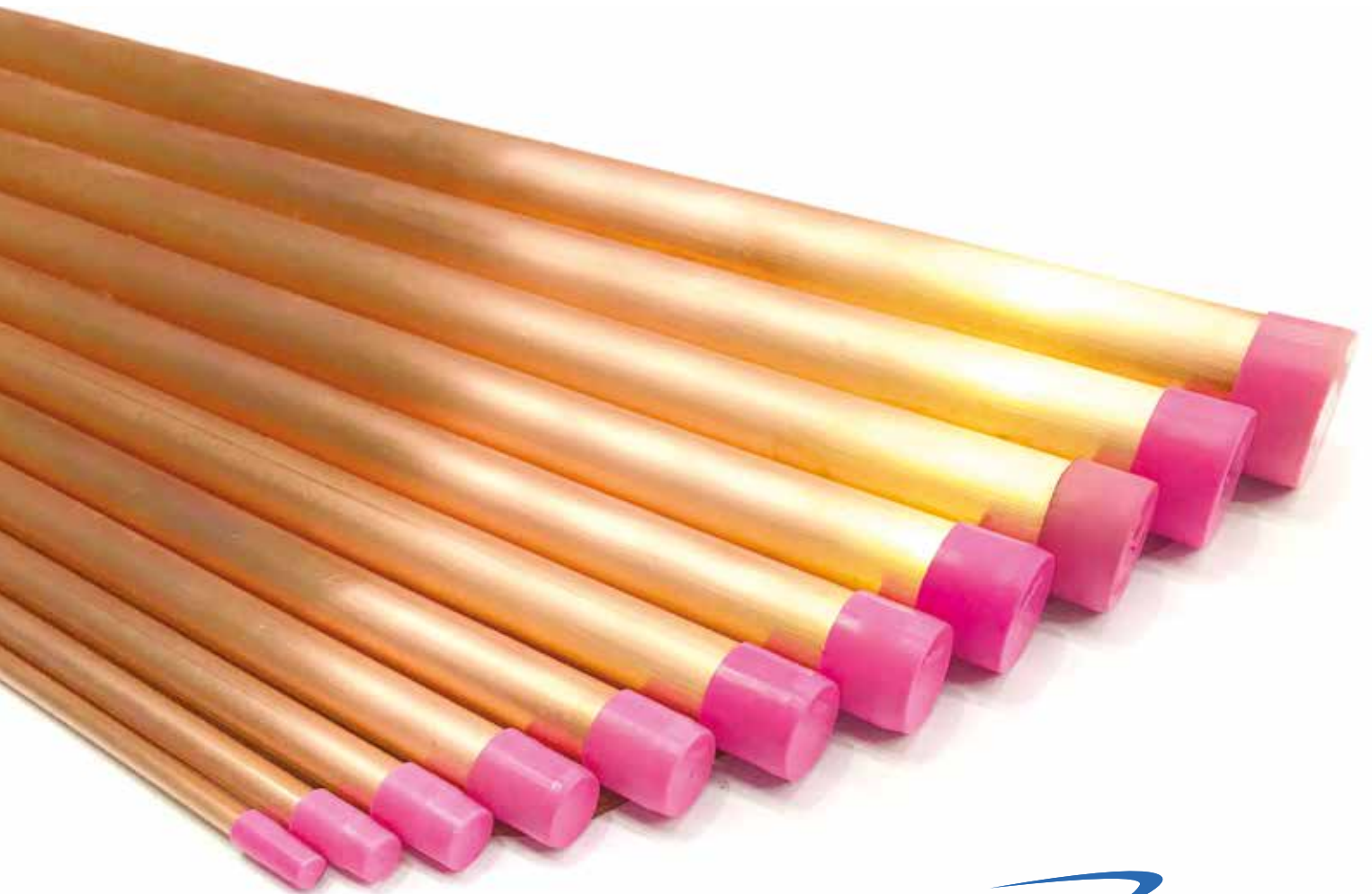

IN STOCK | ON SITE | ON TIME

ORDERING OF HVAC MATERIALS MADE EASY

Alpha Supply Pty. Ltd.
51 Assembly Dr, Tullamarine VIC 3043
PO Box 132 Tullamarine VIC 3043
P: +61 (0) 3 9445 0848
F: +61 (0) 3 9445 0849
W: www.alphasupply.com.au
E: sales@alphasupply.com.au

HARD DRAWN COPPER PIPE

REF CU HD R410A 6M-1/4	HDCU06
REF CU HD R410A 6M-3/8	HDCU10
REF CU HD R410A 6M-1/2	HDCU13
REF CU HD R410A 6M-5/8	HDCU16
REF CU HD R410A 6M-3/4	HDCU19
REF CU HD R410A 6M-7/8	HDCU22
REF CU HD R410A 6M-1	HDCU25
REF CU HD R410A 6M-1 1/8	HDCU28
REF CU HD R410A 6M-1 1/4	HDCU32
REF CU HD R410A 6M-1 3/8	HDCU35
REF CU HD R410A 6M-1 5/8	HDCU42



6 Meter Lengths

410a Rated

Manufactured To Australian Standards AS1432

SOFT DRAWN COPPER PIPE

1/4 R410a Soft Drawn Copper Tube - 30m Roll	SDCU06
3/8 R410a Soft Drawn Copper Tube - 18m Roll	SDCU10
1/2 R410a Soft Drawn Copper Tube - 18m Roll	SDCU13
5/8 R410a Soft Drawn Copper Tube - 18m Roll	SDCU16
3/4 R410a Soft Drawn Copper Tube - 18m Roll	SDCU19
7/8 R410a Soft Drawn Copper Tube - 18m Roll	SDCU22



Soft Drawn Roll Copper Tube

410a Rated

Manufactured To Australian Standards AS1432

COPPER PAIR COIL – NON FIRE RATED

PAIR COIL NON Fire Rated 20M -1/4 & 3/8	IPC0610
PAIR COIL NON Fire Rated 20M -1/4 & 1/2	IPC0613
PAIR COIL NON Fire Rated 20M -1/4 & 5/8	IPC0616
PAIR COIL NON Fire Rated 20M -3/8 & 5/8	IPC1016
PAIR COIL NON Fire Rated 20M -3/8 & 3/4	IPC1019
PAIR COIL NON Fire Rated 20M -1/2 & 3/4	IPC1319



20 Meter Rolls Of Copper Tube

410a Rated

Manufactured To Australian Standards AS1432

COPPER PAIR COIL – FIRE RATED 13mm WALL

PAIR COIL FIRE RATED 13MM 20M-1/4 & 3/8	13FR0610
PAIR COIL FIRE RATED 13MM 20M-1/4 & 1/2	13FR0613
PAIR COIL FIRE RATED 13MM 20M-1/4 & 5/8	13FR0616
PAIR COIL FIRE RATED 13MM 20M-3/8 & 5/8	13FR1016
PAIR COIL FIRE RATED 13MM 20M 3/8 & 3/4	13FR1019



20 Meter Rolls Of Copper Tube

Fire Rated

410a Rated

Manufactured To Australian Standards AS1432

COPPER PAIR COIL – FIRE RATED 19mm WALL

PAIR COIL FIRE RATED 19MM 18M-1/4 & 3/8	19FR0610
PAIR COIL FIRE RATED 19MM 18M-1/4 & 1/2	19FR0613
PAIR COIL FIRE RATED 19MM 18M-1/4 & 5/8	19FR0616
PAIR COIL FIRE RATED 19MM 18M-3/8 & 5/8	19FR1016



18 Meter Rolls Of Copper Tube

Fire Rated

410a Rated

Manufactured To Australian Standards AS1432

COPPER ELBOW F & F – 90 DEGREE

REF CU ELBOW 90DEG F+F R410A-1/4	CU9006
REF CU ELBOW 90DEG F+F R410A-3/8	CU9010
REF CU ELBOW 90DEG F+F R410A-1/2	CU9013
REF CU ELBOW 90DEG F+F R410A-5/8	CU9016
REF CU ELBOW 90DEG F+F R410A-3/4	CU9019
REF CU ELBOW 90DEG F+F R410A-7/8	CU9022
REF CU ELBOW 90DEG F+F R410A-1	CU9025
REF CU ELBOW 90DEG F+F R410A-1 1/8	CU9028
REF CU ELBOW 90DEG F+F R410A-1 1/4	CU9032
REF CU ELBOW 90DEG F+F R410A-1 3/8	CU9035
REF CU ELBOW 90DEG F+F R410A-1 5/8	CU9042



COPPER ELBOW F & F – 45 DEGREE

REF CU ELBOW 45DEG R410A-3/8	CU4506
REF CU ELBOW 45DEG R410A-1/2	CU4510
REF CU ELBOW 45DEG R410A-5/8	CU4513
REF CU ELBOW 45DEG R410A-3/4	CU4516
REF CU ELBOW 45DEG R410A-7/8	CU4522
REF CU ELBOW 45DEG R410A-1"	CU4525
REF CU ELBOW 45DEG R410A-1 1/8	CU4528
REF CU ELBOW 45DEG R410A-1 1/4	CU4532
REF CU ELBOW 45DEG R410A-1 3/8	CU4535
REF CU ELBOW 45DEG R410A-1 5/8	CU4542



COPPER ELBOW F & F – 45 DEGREE

REF CU COUPLING F+F R410A-1/4	CUC06
REF CU COUPLING F+F R410A-3/8	CUC10
REF CU COUPLING F+F R410A-1/2	CUC13
REF CU COUPLING F+F R410A-5/8	CUC16
REF CU COUPLING F+F R410A-3/4	CUC19
REF CU COUPLING F+F R410A-7/8	CUC22
REF CU COUPLING F+F R410A-1	CUC25
REF CU COUPLING F+F R410A-1 1/8	CUC28
REF CU COUPLING F+F R410A-1 1/4	CUC32
REF CU COUPLING F+F R410A-1 3/8	CUC35
REF CU COUPLING F+F R410A-1 5/8	CUC42



COPPER REDUCING COUPLING F+F

REF CU RED COUPLING F+F R410A-3/8ID x 1/4ID	CURC1006
REF CU RED COUPLING F+F R410A-1/2ID x 1/4ID	CURC1306
REF CU RED COUPLING F+F R410A-1/2ID x 3/8ID	CURC1310
REF CU RED COUPLING F+F R410A-5/8ID x 3/8ID	CURC1610
REF CU RED COUPLING F+F R410A-5/8ID x 1/2ID	CURC1613
REF CU RED COUPLING F+F R410A-3/4ID x 3/8ID	CURC1910
REF CU RED COUPLING F+F R410A-3/4ID x 1/2ID	CURC1913
REF CU RED COUPLING F+F R410A-3/4ID x 5/8ID	CURC1916
REF CU RED COUPLING F+F R410A-7/8ID x 1/2ID	CURC2213
REF CU RED COUPLING F+F R410A-7/8ID x 5/8ID	CURC2216
REF CU RED COUPLING F+F R410A-7/8ID x 3/4ID	CURC2219
REF CU RED COUPLING F+F R410A-1-1/8ID x 5/8ID	CURC2816
REF CU RED COUPLING F+F R410A-1-1/8ID x 3/4ID	CURC2819
REF CU RED COUPLING F+F R410A-1-1/8ID x 7/8ID	CURC2822



COPPER BUSH

REF CU BUSH M+F R410A-1-1/8OD x 5/8ID	CUBUR411858
REF CU BUSH M+F R410A-1-1/8OD x 7/8ID	CUBUR411878
REF CU BUSH M+F R410A-1/2OD x 1/4ID	CUBUR41214
REF CU BUSH M+F R410A-1/2OD x 3/8ID	CUBUR41238
REF CU BUSH M+F R410A-1-3/8OD x 1 1/8ID	CUBUR4138118
REF CU BUSH M+F R410A-1-3/8OD x 7/8ID	CUBUR413878
REF CU BUSH M+F R410A-1-5/8OD x 1 3/8ID	CUBUR4158138
REF CU BUSH M+F R410A-3/4OD x 1/2ID	CUBUR43412
REF CU BUSH M+F R410A-3/4OD x 5/8ID	CUBUR43458
REF CU BUSH M+F R410A-3/8OD x 1/4ID	CUBUR43814
REF CU BUSH M+F R410A-5/8OD x 1/2ID	CUBUR45812
REF CU BUSH M+F R410A-5/8OD x 3/8ID	CUBUR45838
REF CU BUSH M+F R410A-7/8OD x 1/2ID	CUBUR47812
REF CU BUSH M+F R410A-7/8OD x 3/4ID	CUBUR47834
REF CU BUSH M+F R410A-7/8OD x 5/8ID	CUBUR47858



COPPER END STOP

REF CU STOP END R410A-3/8	CUEND10
REF CU STOP END R410A-1/2	CUEND13
REF CU STOP END R410A-5/8	CUEND16
REF CU STOP END R410A-3/4	CUEND19
REF CU STOP END R410A-7/8	CUEND22
REF CU STOP END R410A-1	CUEND25
REF CU STOP END R410A-1 1/8	CUEND28
REF CU STOP END R410A-1 3/8	CUEND35
REF CU STOP END R410A-1 5/8	CUEND42



COPPER EQUAL TEE

REF CU EQUAL TEE R410A-1/4	CUTEE06
REF CU EQUAL TEE R410A-3/8	CUTEE10
REF CU EQUAL TEE R410A-1/2	CUTEE13
REF CU EQUAL TEE R410A-5/8	CUTEE16
REF CU EQUAL TEE R410A-3/4	CUTEE19
REF CU EQUAL TEE R410A-7/8	CUTEE22
REF CU EQUAL TEE R410A-1 1/8	CUTEE28
REF CU EQUAL TEE R410A-1 3/8	CUTEE35



COPPER P TRAP

REF CU P TRAP 410a - 5/8	CUPT58
REF CU P TRAP 410a - 3/4	CUPT34
REF CU P TRAP 410a - 7/8	CUPT78
REF CU P TRAP 410a - 1-1/8	CUPT118
REF CU P TRAP 410a - 1-3/8	CUPT138
REF CU P TRAP 410a - 1-5/8	CUPT158



BRASS MALE FLARE UNION

UNION BR MFL-1/2 x 1/2	BRMFU1212
UNION BR MFL-1/4 x 1/4	BRMFU1414
UNION BR MFL-3/4 x 3/4	BRMFU3434
UNION BR MFL-3/8 x 3/8	BRMFU3838
UNION BR MFL-5/8 x 5/8	BRMFU5858



SCHRADER ACCESS VALVE

SCHRADER VALVE 1/4 CU TAIL-1/4FL	SV06
SCHRADER VALVE 1/4 CU TAIL-5/16FL	SV08
SCHRADER CAP BR R410A	SCR410A
SCHRADER VALVE CORE R410A	VCORE



FLARE NUTS

FLARE NUT BR -1/4	BRFN06
FLARE NUT BR -3/8	BRFN10
FLARE NUT BR -1/2	BRFN13
FLARE NUT BR -5/8	BRFN16
FLARE NUT BR -3/4	BRFN19



SILVER SOLDER

SILVER SOLDER 2.5MMX750MM 2%	SBR02
SILVER SOLDER 2.5MMX750MM 5%	SBR05
SILVER SOLDER 2.5MMX750MM 15%	SBR15



FLUX PASTE

FLUX PASTE EZYFLO	EASYF
-------------------	-------



Preferred General Purpose Flux
Suitable For Most Engineering Materials

FLUX PASTE

STAY BRITE SOLDER 453G	STAYB
STAY CLEAN FLUX 110G	STAYC



Low Temperature Silver Solder
Ability To Solder Up To 1 1/8 With A Hand Torch
Suitable For Ferrous & Non-Ferrous Metals
Lead Free
Must Use Stay-Clean Flux STAYC With Stay Brite Solder

INSULATION



IN STOCK | ON SITE | ON TIME

ORDERING OF HVAC MATERIALS MADE EASY

Alpha Supply Pty. Ltd.
51 Assembly Dr, Tullamarine VIC 3043
PO Box 132 Tullamarine VIC 3043
P: +61 (0) 3 9445 0848
F: +61 (0) 3 9445 0849
W: www.alphasupply.com.au
E: sales@alphasupply.com.au

FIRE RATED PIPE INSULATION - 9MM

PIPE INSULATION FR 9MM WALL 1/4	FR9INS06
PIPE INSULATION FR 9MM WALL 3/8	FR9INS10
PIPE INSULATION FR 9MM WALL 1/2	FR9INS13
PIPE INSULATION FR 9MM WALL 5/8	FR9INS16
PIPE INSULATION FR 9MM WALL 3/4	FR9INS19
PIPE INSULATION FR 9MM WALL 7/8	FR9INS22
PIPE INSULATION FR 9MM WALL 1	FR9INS25
PIPE INSULATION FR 9MM WALL 1 1/8	FR9INS28
PIPE INSULATION FR 9MM WALL 1 1/4	FR9INS32
PIPE INSULATION FR 9MM WALL 1 3/8	FR9INS35
PIPE INSULATION FR 9MM WALL 1 5/8	FR9INS42



FIRE RATED PIPE INSULATION - 13MM

PIPE INSULATION FR 13MM WALL 1/4	FR13INS06
PIPE INSULATION FR 13MM WALL 3/8	FR13INS10
PIPE INSULATION FR 13MM WALL 1/2	FR13INS13
PIPE INSULATION FR 13MM WALL 5/8	FR13INS16
PIPE INSULATION FR 13MM WALL 3/4	FR13INS19
PIPE INSULATION FR 13MM WALL 7/8	FR13INS22
PIPE INSULATION FR 13MM WALL 1	FR13INS25
PIPE INSULATION FR 13MM WALL 1 1/8	FR13INS28
PIPE INSULATION FR 13MM WALL 1 1/4	FR13INS32
PIPE INSULATION FR 13MM WALL 1 3/8	FR13INS35
PIPE INSULATION FR 13MM WALL 1 5/8	FR13INS42



FIRE RATED PIPE INSULATION - 19MM

PIPE INSULATION FR 19MM WALL 1/4	FR19INS06
PIPE INSULATION FR 19MM WALL 3/8	FR19INS10
PIPE INSULATION FR 19MM WALL 1/2	FR19INS13
PIPE INSULATION FR 19MM WALL 5/8	FR19INS16
PIPE INSULATION FR 19MM WALL 3/4	FR19INS19
PIPE INSULATION FR 19MM WALL 7/8	FR19INS22
PIPE INSULATION FR 19MM WALL 1	FR19INS25
PIPE INSULATION FR 19MM WALL 1 1/8	FR19INS28
PIPE INSULATION FR 19MM WALL 1 1/4	FR19INS32
PIPE INSULATION FR 19MM WALL 1 3/8	FR19INS35
PIPE INSULATION FR 19MM WALL 1 5/8	FR19INS42



FIRE RATED PIPE INSULATION - 25MM

PIPE INSULATION FR 25MM WALL 3/8	FR25INS10
PIPE INSULATION FR 25MM WALL 1/2	FR25INS13
PIPE INSULATION FR 25MM WALL 5/8	FR25INS16
PIPE INSULATION FR 25MM WALL 3/4	FR25INS19
PIPE INSULATION FR 25MM WALL 7/8	FR25INS22
PIPE INSULATION FR 25MM WALL 1	FR25INS25
PIPE INSULATION FR 25MM WALL 1 1/8	FR25INS28
PIPE INSULATION FR 25MM WALL 1 1/4	FR25INS32
PIPE INSULATION FR 25MM WALL 1 3/8	FR25INS35
PIPE INSULATION FR 25MM WALL 1 5/8	FR25INS42



INSULATION ADHESIVE

INSULATION ADHESIVE	PIA
---------------------	-----



6 Meter Lengths

410a Rated

Manufactured To Australian Standards AS1432

ZOOMLOCK BRAZE FREE FITTINGS

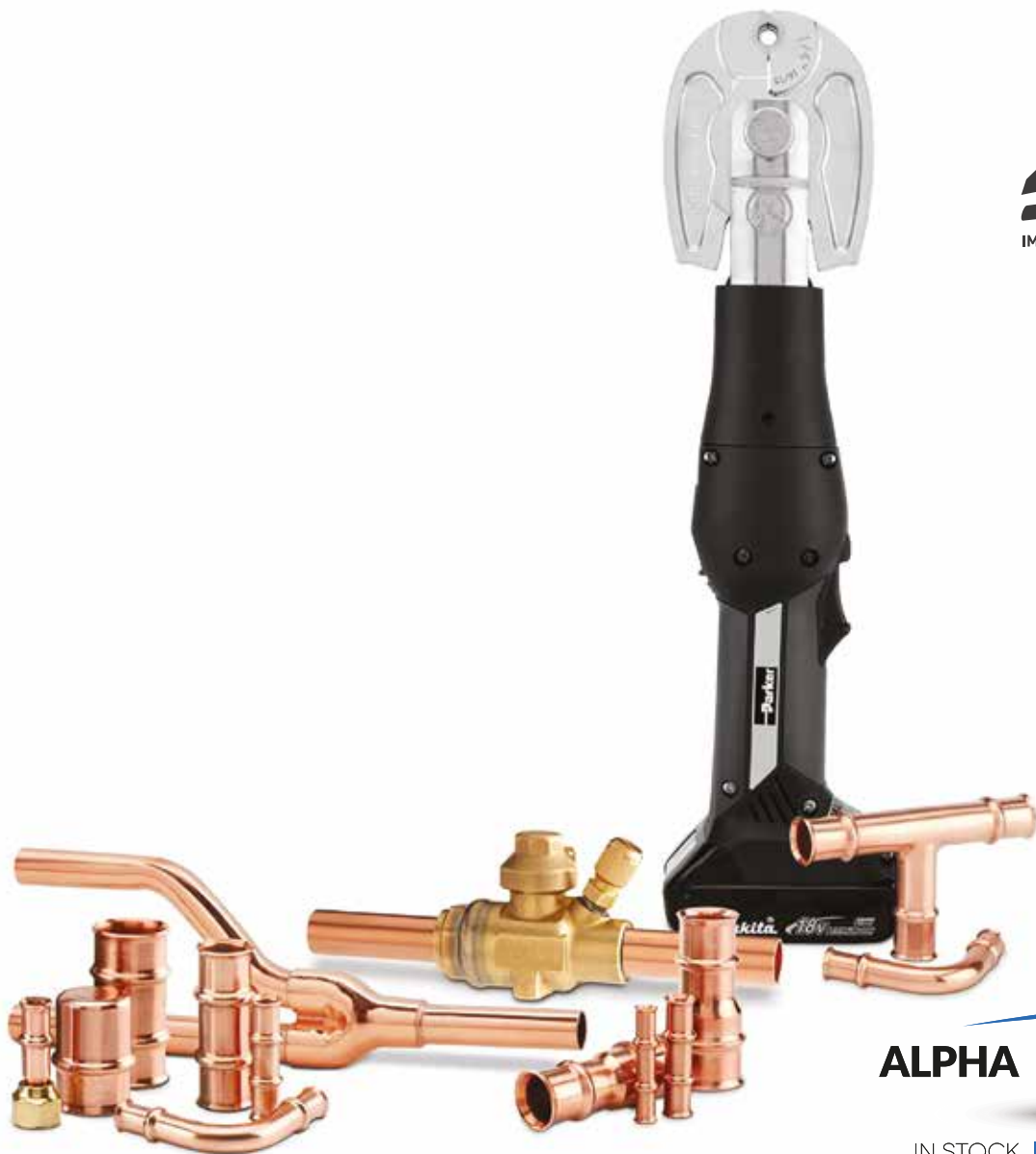

ZoomLock
IMAGINE LIFE WITHOUT BRAZING.

ALPHA  **SUPPLY**

IN STOCK | ON SITE | ON TIME

ORDERING OF HVAC MATERIALS MADE EASY

Alpha Supply Pty. Ltd.
51 Assembly Dr, Tullamarine VIC 3043
PO Box 132 Tullamarine VIC 3043
P: +61 (0) 3 9445 0848
F: +61 (0) 3 9445 0849
W: www.alphasupply.com.au
E: sales@alphasupply.com.au

Welcome to ZoomLock!

MEET ZOOMLOCK THE 10-SECOND FLAME-FREE REFRIGERANT FITTING.



- Ten-second leak-proof refrigerant fitting.
- Reduce labour cost up to 60%
- No brazing. No flame. No fire warden.



ZoomLock offers a braze-free alternative to using Refrigeration Copper Fittings.

With feedback from the many contractors who have already invested in ZoomLock, we confidently guarantee ZoomLock will increase the Speed, Quality, Productivity and Profitability of your installations!

Significant labour savings gives you a quick return on your investment, along with saying goodbye to hassle factors associated with traditional brazing. No more hot works permits, or nitrogen purging, fire wardens, or cooling down time.

A Brilliant Idea. A Simple Solution.

The ZoomLock braze-free connecting process is based on exclusive, patented crimping technology. You only need two hands and a few simple tools. No brazing, no experience and practically no time at all.

ZoomLock BRAZE-FREE TUBE FITTINGS CHANGES EVERYTHING

ZoomLock fittings are specially designed to work without brazing, which automatically makes your job simpler and faster when joining copper tube. In addition, the one-piece fittings are reliably secure, leak-proof and more repeatable than brazed connections - so there's no compromise on quality or performance.



**Fast,
Safe, Clean,
Simple**
Gives your company significant time savings

ZOOMLOCK BRAZE FREE FITTINGS

ORDERING OF HVAC MATERIALS MADE EASY

ZoomLock™

IMAGINE LIFE WITHOUT BRAZING.



Features & Benefits of ZoomLock

ZoomLock™ fittings are specially designed to work without brazing, which automatically makes your job simpler and faster when joining refrigeration copper tubes.

The ZoomLock Advantage

- Increases speed and quality of installations
- No hot work permits required
- No need to nitrogen-purge
- Gives you a clean system
- More flexible access to job sites
- Less equipment and no gas needed
- Safer conditions, no fire hazards
- More environment friendly



Brazing VS ZoomLock Fittings



Quick. Easy. Clean. Repeatable.

- ZoomLock Crimping Tool
- Tube cutter
- De-burring tool
- Depth Gauge
- Scotch-Brite
- Marker Pen

Time-Consuming. Risky. Dirty. Imperfect.

- Torch kit with gas regulators
- Gas tanks (3 - Nitrogen, Acetylene, Oxygen)
- Tube cutter
- De-burring tool
- Brazing Rods
- Scotch-Brite
- Cooling rag
- Access to water
- Solder and flux
- Fire extinguisher
- Fire safety equipment
- Hot Works Permit
- Fire Warden
- Goggles
- Gloves
- Pliers
- Expanders

All together in one simple carry case.



ZoomLock Accessories and Spares

Replacement Parts and Accessories



ZoomLock Jaw



ZoomLock Makita 18V Battery Charger

240V battery charger for 18V Li-Ion batteries. Extremely short charging time.



ZoomLock Makita 18V 1.5Ah Rechargeable Battery

High performance, 1.5 Ah, 18V Li-Ion battery.

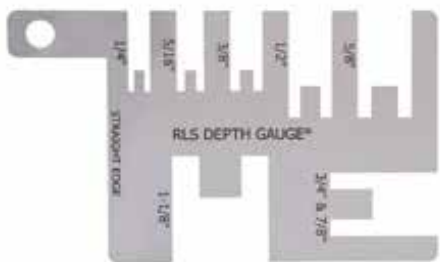

ZoomLock Insertion Depth Tool

Metal depth gauge confirms the proper insertion depth of the tubing.



ZoomLock Crimp Gauge

Confirms the measurement of the finished crimp band diameter



For illustration purposes only

Tubing Cutter

ZoomLock approved tubing cutter



ZoomLock Tube Deburring Tool



For illustration purposes only

ZoomLock Marker Pen



ZoomLock Scotch Brite Scourer Pad

Installation Instructions



Step 1

Slide battery into charger. Plug charger into a power source. Check to see that the charging light is on. When red lights turn off and green light turns on, battery is fully charged - 20 minutes.

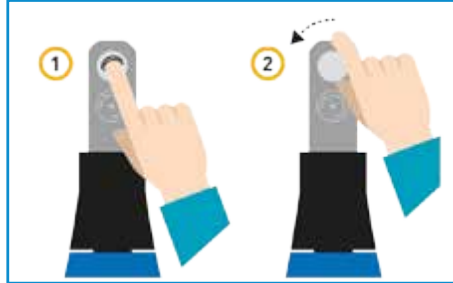

Step 2

Press the locking pin, then rotate 45° to release.

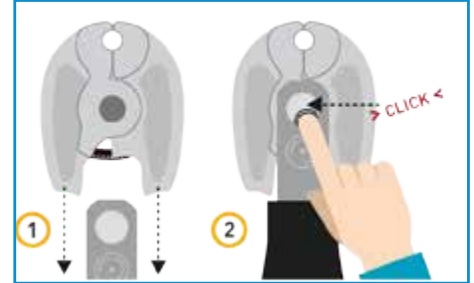

Step 3

Slide jaws over Crimping Tool head, then depress locking pin until it clicks.



Step 4

Slide charged battery into base of Crimping Tool.



Step 5

Press and hold trigger and Crimping Tool to calibrate. **Calibration is recommended daily, prior to use.**



Step 6

Cut the copper tube using the **supplied** tube cutter. Do **NOT** use a hacksaw or reciprocating saw as this creates a rough surface that may damage the o-ring.

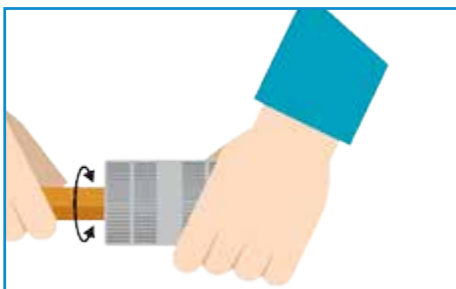

Step 7

Use the **supplied** deburring tool to remove any residual burrs from the outside and inside of the copper tube.

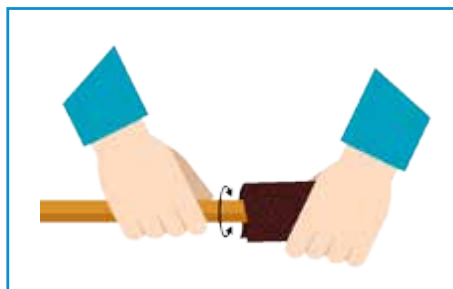

Step 8

Use a heavy duty scouring pad to clean the ends of the copper tubes to be joined. Tube ends should be free and clear of oxidation, or debris.

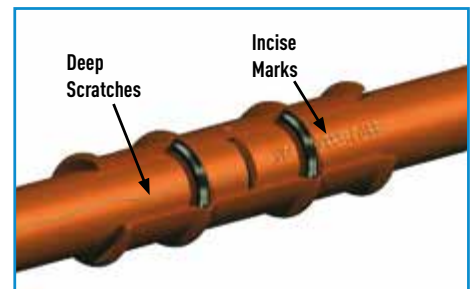

Step 9

Inspect the copper tube for imperfections such as deep surface scratches and incise marks within the o-ring sealing area that may provide a leak path for refrigerant. If scratches are present, cut off the affected area or sand thoroughly to remove.

WARNING: COPPER TUBE ENDS SHOULD BE INSPECTED AND ANY SHARP EDGES SHOULD BE ADDRESSED, SHARP EDGES MAY CAUSE DAMAGE TO THE O-RING.

Installation Instructions Cont

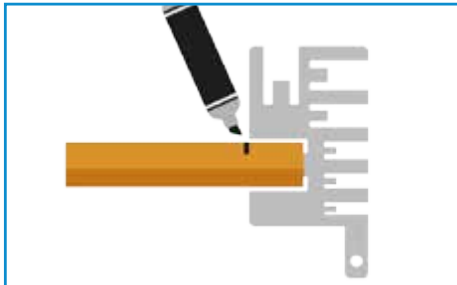

Step 10

Using the depth gauge provided determine the minimum insertion depth. Mark the tubing with a permanent marker to indicate proper insertion depth on every tube.



Step 11

Ensure both 'O' rings are correctly located in the fittings. Push the fitting onto the tube. Use the mark to assure insertion depth and secure fit.

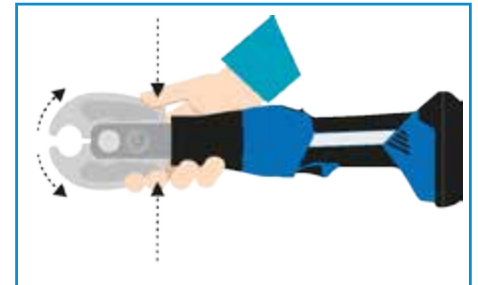

Step 12

Open the jaws of the ZoomLock Crimping Tool.

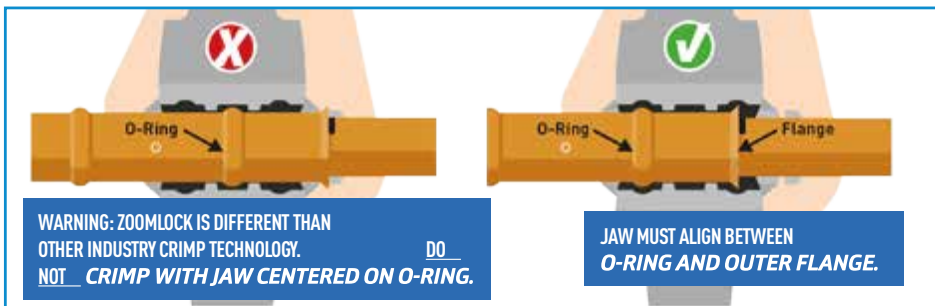

Step 13

Properly place the crimping jaws onto the fitting. Grooves in the jaws make it easy to align. See illustration above right for proper crimping alignment.



Step 14

Press and hold the trigger on the ZoomLock Crimping Tool to begin the crimping process. Continue to hold the trigger until the ZoomLock Crimping Tool completes its cycle.

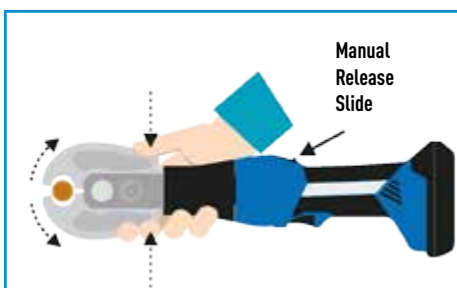

Step 15

Open the jaws of the ZoomLock Crimping Tool and remove from the fitting. If the jaws do not open, the crimping cycle was not completed. For manual override, slide the manual release button down to open the jaw in case of emergency.

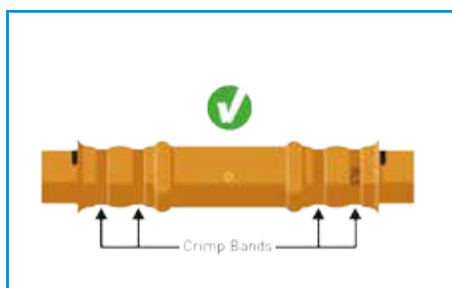

Step 16

A special "RLS" mark will be displayed on the tube to let you know the connection is crimped properly.



Step 17

The supplied RLS CrimpGauge will confirm the measurement of the finished crimp band diameter. See crimp band locations noted in Step 16. It may be necessary to rotate the gauge in order to not interfere with the copper tube flashing left from the crimping process.

ZOOMLOCK 410a BRAZE FREE CRIMPING TOOL

ZOOMLOCK TOOL ZMLTOOL



For HVAC/R up to 700 psi

NO torch needed!

Hard and soft Copper Tube to Copper Connections

Short pressing cycle, 5-7 seconds!

JAWS

ZOOMLOCK JAW KL 1/4	ZLKJAW14
ZOOMLOCK JAW KL 3/8	ZLKJAW38
ZOOMLOCK JAW KL 1/2	ZLKJAW12
ZOOMLOCK JAW KL 5/8	ZLKJAW58
ZOOMLOCK JAW KL 3/4	ZLKJAW34
ZOOMLOCK JAW KL 7/8	ZLKJAW78
ZOOMLOCK JAW KL 1 - 1/8	ZLKJAW118
ZOOMLOCK JAW KL 1 - 3/8	ZLKJAW138



ACCESSORIES

ZOOMLOCK DEPTH INS GAUGE-Metal	ZLDIGM
ZOOMLOCK DEPTH INS GAUGE-Plastic	ZLDIGP
ZOOMLOCK DEBURRING TOOL	ZLDT
ZOOMLOCK CRIMP GAUGE	ZLCG



COUPLINGS

ZOOMLOCK COUPLING-1/4	ZLCC06
ZOOMLOCK COUPLING-3/8	ZLCC10
ZOOMLOCK COUPLING-1/2	ZLCC13
ZOOMLOCK COUPLING-5/8	ZLCC16
ZOOMLOCK COUPLING-3/4	ZLCC19
ZOOMLOCK COUPLING-7/8	ZLCC22
ZOOMLOCK COUPLING-1 1/8	ZLCC28
ZOOMLOCK COUPLING-1 3/8	ZLCC35



ELBOWS

ZOOMLOCK 90 LR ELBOW-1/4	ZL90LR06
ZOOMLOCK 90 LR ELBOW-3/8	ZL90LR10
ZOOMLOCK 90 LR ELBOW-1/2	ZL90LR13
ZOOMLOCK 90 LR ELBOW-5/8	ZL90LR16
ZOOMLOCK 90 LR ELBOW-3/4	ZL90LR19
ZOOMLOCK 90 LR ELBOW-7/8	ZL90LR22
ZOOMLOCK 90 LR ELBOW-1 1/8	ZL90LR28
ZOOMLOCK 90 LR ELBOW-1 3/8	ZL90LR35



CONDENSATE REMOVAL



ALPHA  **SUPPLY**

IN STOCK | ON SITE | ON TIME

ORDERING OF HVAC MATERIALS MADE EASY

Alpha Supply Pty. Ltd.
51 Assembly Dr, Tullamarine VIC 3043
PO Box 132 Tullamarine VIC 3043
P: +61 (0) 3 9445 0848
F: +61 (0) 3 9445 0849
W: www.alphasupply.com.au
E: sales@alphasupply.com.au

AIRCONDITIONING & REFRIGERATION CONDENSATE PIPE

AC&R PVC DRAIN PIPE (3.9M)-15mm	ACRDP415
AC&R PVC DRAIN PIPE (3.9M)-20mm	ACRDP420
AC&R PVC DRAIN PIPE (3.9M)-25mm	ACRDP425
AC&R PVC DRAIN PIPE (3.9M)-32mm	ACRDP432



90 DEGREE ELBOW PRESSURE FITTING

PVC ELBOW 90DEG-15mm	PVC90EL15
PVC ELBOW 90DEG-20mm	PVC90EL20
PVC ELBOW 90DEG-25mm	PVC90EL25
PVC ELBOW 90DEG-32mm	PVC90EL32



45 DEGREE ELBOW PRESSURE FITTING

PVC ELBOW 45DEG-15mm	PVC45EL15
PVC ELBOW 45DEG-20mm	PVC45EL20
PVC ELBOW 45DEG-25mm	PVC45EL25
PVC ELBOW 45DEG-32mm	PVC45EL32



PVC EQUAL TEE PRESSURE FITTING

PVC EQUAL TEE-15mm	PVCTEE15
PVC EQUAL TEE-20mm	PVCTEE20
PVC EQUAL TEE-25mm	PVCTEE25
PVC EQUAL TEE-32mm	PVCTEE32



PVC DOUBLE END SOCKET PRESSURE FITTING

PVC D/ENC SOCKET-15mm	PVCDS15
PVC D/ENC SOCKET-20mm	PVCDS20
PVC D/ENC SOCKET-25mm	PVCDS25
PVC D/ENC SOCKET-32mm	PVCDS32



PVC REDUCING SOCKET PRESSURE FITTING

PVC RED SOCKET-20mm x 15mm	PVCRS2015
PVC RED SOCKET-25mm x 15mm	PVCRS2515
PVC RED SOCKET-25mm x 20mm	PVCRS2520
PVC RED SOCKET-32mm x 20mm	PVCRS3220
PVC RED SOCKET-32mm x 25mm	PVCRS3225



PVC REDUCING BUSH PRESSURE FITTING

PVC RED BUSH-20mm x 15mm	PVCRB2015
PVC RED BUSH-25mm x 15mm	PVCRB2515
PVC RED BUSH-25mm x 20mm	PVCRB2520
PVC RED BUSH-32mm x 20mm	PVCRB3220
PVC RED BUSH-32mm x 25mm	PVCRB3225

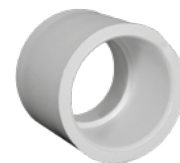

PVC FEMALE THREADED ADAPTOR PRESSURE FITTING

PVC FEMALE THREADED ADAPTOR -15mm	PVCFI15
PVC FEMALE THREADED ADAPTOR -20mm	PVCFI20
PVC FEMALE THREADED ADAPTOR -25mm	PVCFI25



PVC FEMALE THREADED ADAPTOR PRESSURE FITTING

PVC MALE THREADED ADAPTOR-15mm	PVCFMI15
PVC MALE THREADED ADAPTOR-20mm	PVCFMI20
PVC MALE THREADED ADAPTOR-25mm	PVCFMI25



PVC END CAP PRESSURE FITTING

PVC END CAP-15mm	PVCCAP15
PVC END CAP-20mm	PVCCAP20
PVC END CAP-25mm	PVCCAP25
PVC END CAP-32mm	PVCCAP32



DRAIN WASTE VENT (DWV) PIPE

DWV PIPE SWJ 6M -40mm	DWVLEN040
DWV PIPE SWJ 6M -50mm	DWVLEN050
DWV PIPE SWJ 6M -65mm	DWVLEN065
DWV PIPE SWJ 6M -80mm	DWVLEN080
DWV PIPE SWJ 6M -100mm	DWVLEN100
DWV PIPE SWJ 6M -150mm	DWVLEN150



DRAIN WASTE VENT (DWV) 85 DEGREE ELBOW

DWV ELBOW 85DEG-40mm	DWV90040
DWV ELBOW 85DEG-50mm	DWV90050
DWV ELBOW 85DEG-65mm	DWV90065
DWV ELBOW 85DEG-80mm	DWV90080
DWV BEND 85DEG-100mm	DWV90100
DWV BEND 85DEG-150mm	DWV90150



DRAIN WASTE VENT (DWV) 45 DEGREE

DWV ELBOW 45DEG-40mm	DWV45040
DWV ELBOW 45DEG-50mm	DWV45050
DWV ELBOW 45DEG-65mm	DWV45065
DWV ELBOW 45DEG-80mm	DWV45080
DWV ELBOW 45DEG-100mm	DWV45100
DWV ELBOW 45DEG-150mm	DWV45150



DRAIN WASTE VENT (DWV) JUNCTION

DWV JUNCTION F+F 85DEG-40mm	DWVJ040
DWV JUNCTION F+F 85DEG-50mm	DWVJ050
DWV JUNCTION F+F 85DEG-65mm	DWVJ065
DWV JUNCTION F+F 85DEG-80mm	DWVJ080
DWV JUNCTION F+F 85DEG-100mm	DWVJ100
DWV JUNCTION F+F 85DEG-150mm	DWVJ150



DRAIN WASTE VENT (DWV) COUPLING

DWV COUPLING F+F-40mm	DWVC040
DWV COUPLING F+F-50mm	DWVC050
DWV COUPLING F+F-65mm	DWVC065
DWV COUPLING F+F-80mm	DWVC080
DWV COUPLING F+F-100mm	DWVC100
DWV COUPLING F+F-150mm	DWVC150



STORMWATER PIPE – 6 METER LENGTHS

STORMWATER PIPE SWJ 6M-90mm	SWP090
STORMWATER PIPE SWJ 6M-150mm	SWP150
STORMWATER PIPE SWJ 6M-225mm	SWP225



Used also in ventilation applications

STORMWATER 90 DEGREE ELBOW

STORMWATER BEND 87D F+F-90mm	SW90090
STORMWATER BEND 87D F+F-150mm	SW90150
STORMWATER BEND 87D F+F-225mm	SW90225



STORMWATER 45 DEGREE ELBOW

STORMWATER BEND 45D F+F-90mm	SW45090
STORMWATER BEND 45D F+F-150mm	SW45150
STORMWATER BEND 45D F+F-225mm	SW45225



STORMWATER JUNCTION

STORMWATER JUNCTION 87D F+F-90mm	SWJ090
STORMWATER JUNCTION 87D F+F-150mm	SWJ150
STORMWATER JUNCTION 87D F+F-225mm	SWJ225



CONDENSATE REMOVAL

ORDERING OF HVAC MATERIALS MADE EASY

EZ TRAP

EZTRAP-20mm	EZTRAP20
EXTRAP-25mm	EZTRAP25



25mm Ez Trap comes complete with a service cleaning brush

Watertight caps for easy access to clean

Transparent trap for easy visual service inspection

HVAC AIR TRAP

HVAC AIR TRAP	HVACAT
---------------	--------



Never freeze and break

Reduces trap height by up to 60%

For Use as Negative or Positive Trap

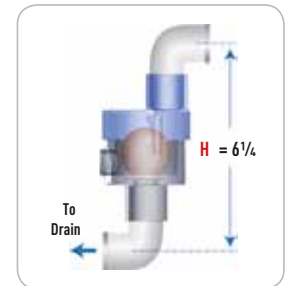
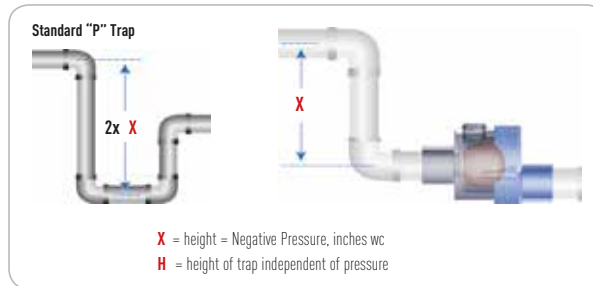
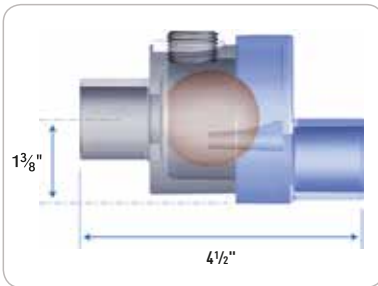

No More Troublesome "P" Traps

- The **Air-Trap** will never freeze and break
- No more issues caused by traps drying out
- **Air-Trap** is predesigned to prevent field errors
- **Air-Trap** reduces trap height by up to 60%
- Eliminates sludge build-up at bottom of "U" tube
- No more geysers when there is negative pressure
- No more blow through with positive pressure

Negative Pressure - Orientation is Horizontal

- Condensate flow up to 4 GPM at any negative pressure
- Schedule 40 PVC with clean out port
- Retains no water after condensing has ceased
- 3/4" slip internal or 1" fitting external connection - with bushings can connect to 1/2, 1 1/4, 1 1/2 and 2" tubes
- Meets general building codes. For use on HVAC equipment only. Not for use as a sanitary trap.

Positive Pressure - Orientation is Vertical

- Up to 3-inches positive pressure
- Up to 0.5 GPM water flow 40 (€ons)

CLEAR VINYL TUBE

CLEAR VINYL TUBE-6mm	CVT06
CLEAR VINYL TUBE-10mm	CVT10
CLEAR VINYL TUBE-20mm	CVT20
CLEAR VINYL TUBE-25mm	CVT25
CLEAR VINYL TUBE-32mm	CVT32
CLEAR VINYL TUBE-40mm	CVT40



CLEAR VINYL TUBE CONNECTOR

CVT CONNECTOR-6mm	CVTCON6
-------------------	---------



XTRA ACCESSORIES KIT

XTRA ACCESSORIES KIT	XTRAKIT
----------------------	---------



HOSE CLAMPS

HOSE CLAMP-13-20mm	HCSS1320
HOSE CLAMP-16-27mm	HCSS1627
HOSE CLAMP-22-32mm	HCSS2232
HOSE CLAMP-30-42mm	HCSS3042
HOSE CLAMP-40-57mm	HCSS4057



FLEXIBLE DRAIN HOSE

REINFORCED FLEXI DRAIN HOSE 16MM X 25M	SWFDH2516
--	-----------



STAND OFF BRACKET

STAND OFF BRACKET	SOBRAC
CLIP HEAD SUIT PVC 15mm	CHPVC15
CLIP HEAD SUIT PVC 20mm	CHPVC20
CLIP HEAD SUIT PVC 25mm	CHPVC25
CLIP HEAD SUIT PVC 32mm	CHPVC32
CLEAR VINYL TUBE-40mm	CVT40



PIPE SADDLE – POWDERCOATED

P/COAT SADDLE SUIT PVC-15mm	SADPVC015
P/COAT SADDLE SUIT PVC-20mm	SADPVC020
P/COAT SADDLE SUIT PVC-25mm	SADPVC025
P/COAT SADDLE SUIT PVC-32mm	SADPVC032
P/COAT SADDLE SUIT PVC-40mm	SADPVC040
P/COAT SADDLE SUIT PVC-50mm	SADPVC050



Manufactured To Suit Pressure Pipe Drain Sizes

MAX FIT DOUBLE BOLTED WELDED NUT CLIP

MAX FIX NUT CLIP 20-25mm (Suit 15mm PVC)	MFNC020025
MAX FIX NUT CLIP 26-30mm (Suit 20mm PVC)	MFNC026030
MAX FIX NUT CLIP 32-36mm (Suit 25mm PVC)	MFNC032036
MAX FIX NUT CLIP 38-43mm (Suit 32mm PVC)	MFNC038043



Non Insulated

Suits M10 Threaded Rod

Zinc Plated High Strength Design

Ideal For Installing PVC Air Conditioning & Refrigeration Drain

DRAIN WASTE VENT (DWV) SADDLE

DWV SADDLE-40mm	DWVSAD040
DWV SADDLE-65mm	DWVSAD065
DWV SADDLE-80mm	DWVSAD080
DWV SADDLE-100mm	DWVSAD100



CONDENSATE REMOVAL

ORDERING OF HVAC MATERIALS MADE EASY

CONDENSATE PUMP – ASPEN MINI ORANGE

MINI ORANGE PUMP MINORG



World's best selling mini pump!

Submersible secondary reservoir included

Plug & play

Anti siphon device

IN THE BOX

Mini Orange pump • 1.5m Plug & play power cable • Reservoir Reservoir lid with 1.5m sensor cable • Submersible reservoir • Anti siphon device Float & filter • 1.5m Suction tube 6mm ID • 220mm Orange inlet hose 14mm ID 150mm Vinyl breather tube 6mm ID • Drain connector kit • Fixing kit • Install manual



12L/h max. flow

KEY FEATURES

- Submersible secondary reservoir included
- Plug & play
- Anti siphon device



10m max. rec. head (flow rate 6L/h)



21dB(A)

SUITABILITY

- Up to 16kW / 54,000Btu/h
- High wall split systems; Ducted units; Floor standing & Chassis units



MINI ORANGE SPECIFICATIONS

Max. flow	12L/h @ 0 head
Max. rec. head	10m
Max. suction lift	2m
Sound level@1m	21dB(A)
Power supply	230 VAC, 0.11A, 16W, 50/60Hz
Rated	Non continuous
Class	II appliance <input type="checkbox"/>
Max. unit output	16kW / 54,000 Btu/h
Max. water temp	40 °C / 104 °F
Discharge tube	6mm ID
IP Protection	IP21
Safety switch	3.0A Normally closed
Thermal protection	✓
Fully potted	✓
Self priming	✓

✓ Perfect for... Smaller commercial & domestic units

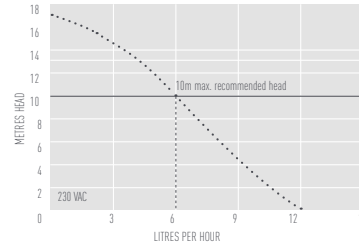
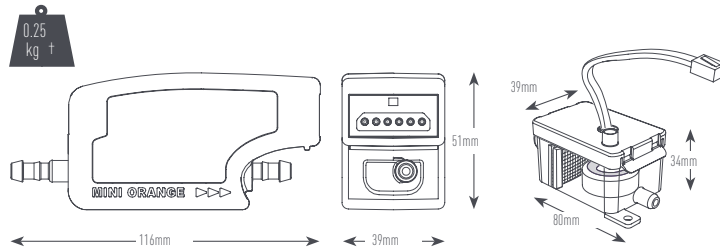

CONDENSATE PUMP – ASPEN MAXI ORANGE

MAXI ORANGE PUMP MAXORG



Designed for larger units

Extra power when you need it

Submersible secondary reservoir included

IN THE BOX

Maxi Orange pump • 1.5m Plug & play power cable • Reservoir • Reservoir lid with 1.5m sensor cable • Submersible reservoir • Anti siphon device • Float & filter • 1.5m Suction tube 6mm ID • 220mm Orange inlet hose 14mm ID • 150mm Vinyl breather tube 6mm ID • Drain connector kit • Fixing kit • Install manual



35L/h max. flow

KEY FEATURES

- High power motor
- Superior performance
- Submersible secondary reservoir included



15m max. rec. head (flow rate 10L/h)



35dB(A)

SUITABILITY

- Up to 46kW / 157,000Btu/h
- High wall split systems; Ducted units; Floor standing & Chassis units



MAXI ORANGE SPECIFICATIONS

Max. flow	35L/h @ 0 head
Max. rec. head	15m
Max. suction lift	2m
Sound level@1m	35dB(A)
Power supply	230 VAC, 0.11A, 16W, 50/60Hz
Rated	Non continuous
Class	II appliance <input type="checkbox"/>
Max. unit output	46kW / 157,000Btu/h
Max. water temp	40 °C / 104 °F
Discharge tube	6mm ID
IP Protection	IP21
Safety switch	3.0A Normally closed
Thermal protection	✓
Fully potted	✓
Self priming	✓

✓ Perfect for... Large commercial units

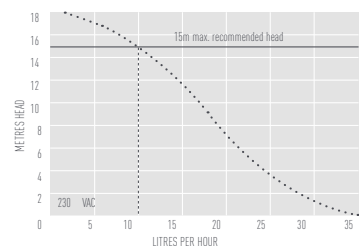
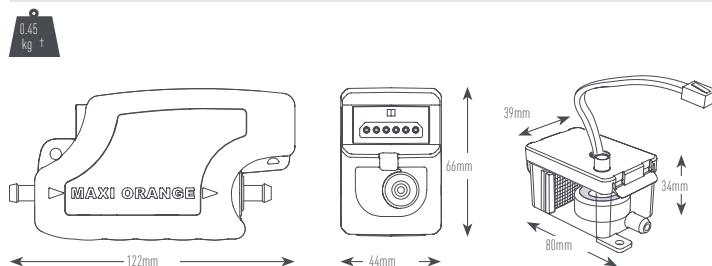

CONDENSATE PUMP – MICRO V14 PUMP

MICRO V14 PUMP MICROV14



Small sensor with visual pump status diagnostics

Continuous rating

Soft start

No breather tube

IN THE BOX

- Micro-v i4 pump includes: Water sensor fitted with 850mm interface cable terminated with a plug (removable sensor bracket attached) • Adaptive pump fitted with 1m interface cable and 1m x 6mm violet tube (anti siphon device fitted) • Universal voltage power supply fitted with 500mm plug and play combined power and high water level cores • AV Pump bracket & sleeve • 1 amp fuse
- Inline filter • 90° elbow drain connector & fixing kit • Install manual



14.5L/h max. flow

KEY FEATURES

- Continuous rating
- Soft start
- No breather tube
- Plug & Play
- UniVolt



10m max. rec. head (flow rate 6L/h)

SUITABILITY

- Up to 19.3kW / 66,000Btu/h
- High wall split systems; Ducted units; Floor standing & Chassis units



19dB(A)

✓ Perfect for... Installing directly inside the unit

MICRO-V i4 SPECIFICATIONS

Max. flow	14.5L/h @ 0 head
Max. rec. head	10m
Max. suction lift	2m
Sound level@1m	19dB(A)
Power supply	100-240V, 50-60Hz 0.45A*
Rated	Continuous
Class	II appliance <input type="checkbox"/>
Max. unit output	19.3kW / 66,000Btu/h
Max. water temp	40 °C / 104 °F
Discharge tube	6mm ID
IP Protection	IPX4
Safety switch	3.0A Normally closed
Thermal protection	✓
Fully potted	✓
Self priming	✓

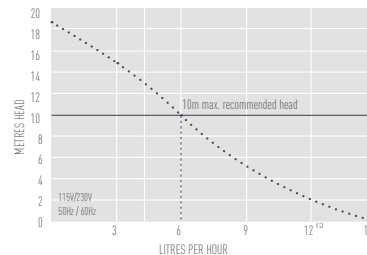
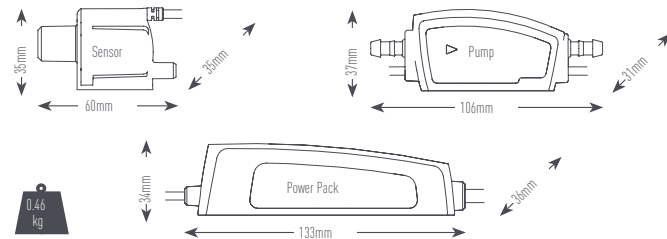

CONDENSATE PUMP – ASPEN MINI LIME

MINI LIME SILENT PUMP MINLIME



One piece elbow pump

Compact design

Left or right install

Trunking system options

IN THE BOX

- Mini Lime pump (including 300mm 6mm ID discharge tube with connector and 1.5m hard wired power cable) • 220mm Lime green inlet hose 14mm ID • 150mm Vinyl breather tube 6mm ID
- Anti siphon device • Elbow front and back • 800mm Conduit front and back • Internal conduit sleeve (Slimline system only) • Gasket (Slimline, BBJ and Inoac/Inaba systems only)
- Ceiling plate • Drain connector kit • Fixing kit • Install manual



12L/h max. flow

KEY FEATURES

- One piece pump
- Left or right install
- Trunking system options
- Easy access for servicing



10m max. rec. head (flow rate 6L/h)

SUITABILITY

- Up to 16kW / 54,000Btu/h
- High wall split systems



23dB(A)

✓ Perfect for... Commercial use eg. offices, restaurants

MINI LIME SPECIFICATIONS

Max. flow	12L/h @ 0 head
Max. rec. head	10m
Max. suction lift	n/a
Sound level@1m	23dB(A)
Power supply	230V AC 50-60Hz 0.1A*
Rated	Non continuous
Class	II appliance <input type="checkbox"/>
Max. unit output	16kW / 54,000Btu/h
Max. water temp	40 °C / 104 °F
Discharge tube	6mm ID
IP Protection	IPX4
Safety switch	3.0A Normally closed
Thermal protection	✓
Fully potted	✓
Self priming	✓

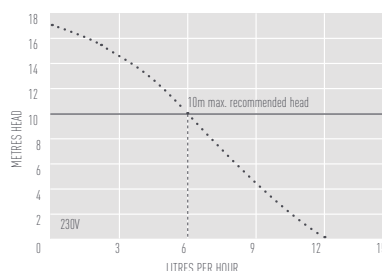
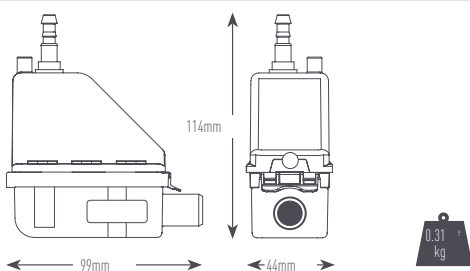

CONDENSATE REMOVAL

ORDERING OF HVAC MATERIALS MADE EASY

CONDENSATE PUMP – ASPEN MAXI LIME

MAXI LIME PUMP MAXLIME



- Sits in trunking elbow
- Range of trunking system
- Left or right install
- Easy access for servicing

IN THE BOX

- Maxi Lime pump (inc. 750mm discharge tube with 6mm ID connector and 1.5m hard wired power cable)
- 220mm Lime green inlet hose 14mm ID
- 150mm Vinyl breather tube 6mm ID
- Anti siphon device
- Elbow front and back
- 800mm conduit front and back
- Internal conduit sleeve (Slimline system only)
- Gasket (BBJ and Inoac/Inaba systems only)
- Ceiling plate
- Drain connector kit
- Fixing kit
- Install manual



35L/h max. flow

KEY FEATURES

- Sits in trunking elbow
- Left or right install
- Range of trunking systems
- Easy access for servicing



15m max. rec. head (flow rate 10L/h)

SUITABILITY

- Up to 46kW / 157,000Btu/h
- High wall split systems



35dB(A)

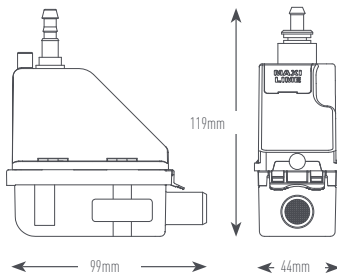

0.47 kg

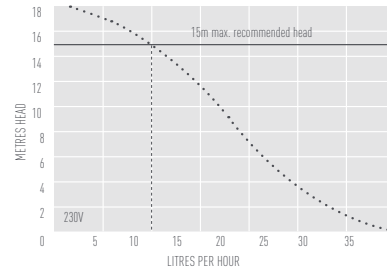

MAXI LIME SPECIFICATIONS

Max. flow	35L/h @ 0 head
Max. rec. head	15m
Max. suction lift	n/a
Sound level@1m	35dB(A)
Power supply	230V AC 50-60Hz 0.1A*
Rated	Non continuous
Class	II appliance <input type="checkbox"/>
Max. unit output	46kW / 157,000Btu/h
Max. water temp	40 °C / 104 °F
Discharge tube	6mm ID
IP Protection	IPX4
Safety switch	3.0A Normally closed
Thermal protection	✓
Fully potted	✓
Self priming	✓

CONDENSATE PUMP – ASPEN MINI BLANC

MINI BLANC PUMP MINBLC

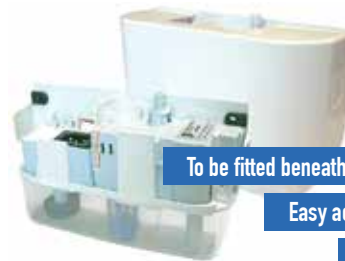

- To be fitted beneath high wall indoor units
- Easy access for maintenance
- Ultra quiet operation

IN THE BOX

- Mini Blanc pump (including hard wired 1.5m power cable)
- Anti siphon device
- Drain connector kit
- Fixing kit
- Install manual



12L/h max. flow

KEY FEATURES

- Extra quick to fit
- Compact & discreet
- Clear removable reservoir
- Ultra quiet operation



10m max. rec. head (flow rate 4L/h)

SUITABILITY

- Up to 16kW / 54,000Btu/h
- High wall mini split systems



21dB(A)

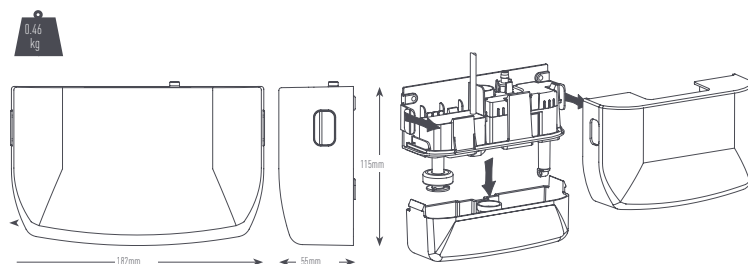

0.46 kg



✓ Perfect for... Domestic use – where easy maintenance is key

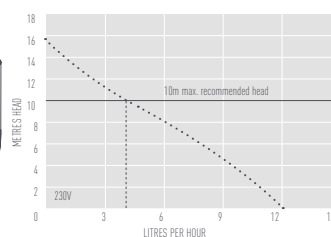

MINI BLANC SPECIFICATIONS

Max. flow	12L/h @ 0 head
Max. rec. head	10m
Max. suction lift	n/a
Sound level@1m	21dB(A)
Power supply	230V AC 50-60Hz 0.1A*
Rated	Non continuous
Class	II appliance <input type="checkbox"/>
Max. unit output	16kW / 54,000Btu/h
Max. water temp	40 °C / 104 °F
Inlet/outlet	20mm in, 6mm out
IP Protection	IPX1
Safety switch	3.0A Normally closed
Thermal protection	✓
Fully potted	✓
Self priming	n/a

CONDENSATE PUMP – ASPEN MINI TANK PUMP

MINI TANK PUMP 1LT MINTANK



Can be located in drain pan

Four ways to install

Compact & discreet

IN THE BOX

Mini Tank pump (including hard wired 1.5m power cable) • x2 Rubber adaptors (21.5mm & 31mm) • Anti siphon device • Fixing kit • Install manual



35L/h max. flow

KEY FEATURES

- Four ways to install
- Compact & discreet
- Can be located in drain pan
- Easy maintenance

SUITABILITY

- Up to 46kW / 157,000Btu/h
- Ducted units; Floor standing & chassis units; Cassette units



MINI TANK SPECIFICATIONS

Max. flow	35L/h @ 0 head
Max. rec. head	15m
Tank capacity	0.24L
Sound level@1m	35dB(A)
Power supply	230V AC 50-60Hz 0.1A*
Rated	Non continuous
Class	II appliance <input type="checkbox"/>
Max. unit output	46kW / 157,000Btu/h
Max. water temp	40 °C / 104 °F
Inlets	x2 22mm, 12mm & 27mm
Outlets	6mm & 10mm
IP Protection	IP67
Safety switch	3.0A Normally closed
Thermal protection	✓
Fully potted	✓
Self priming	✓

✓ Perfect for... Installation versatility

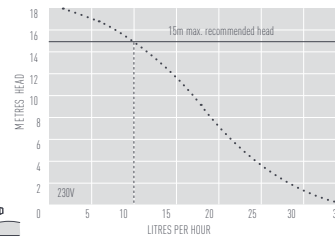
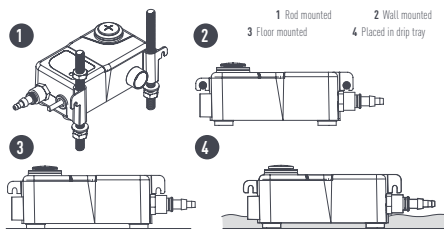
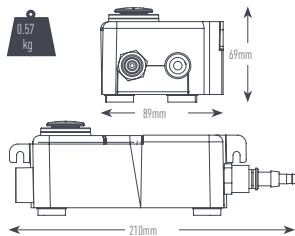

CONDENSATE PUMP – ASPEN MAX HI FLOW

MAX HI FLOW TANK PUMP 2ltr HIFLOTANK



IP24 - Splash proof

Built in spirit level

Plug & play

IN THE BOX

Max Hi-Flow tank pump • Plug & Play power cable • Fixing kit incl. rod mount and wall mount clips • Install manual



550 L/h max. flow

KEY FEATURES

- IP24 - Splash proof
- Easy access tank
- Built in spirit level
- Plug & play

SUITABILITY

- Up to 733kW / 2.5m Btu/h
- Ducted units; Floor standing & Chassis units; Cassette units



HI FLOW SPECIFICATIONS

Max. flow	550L/h @ 0 head
Max. rec. head	5m
Tank capacity	1.7L
Sound level@1m	44 dB(A)
Power supply	230 VAC, 0.8A, 50Hz
Rated	Non continuous
Class	I appliance
Max. unit output	733kW / 2.5m Btu/h
Max. water temp	40 °C / 104 °F
Inlets	x4 21-27mm
Outlets	6mm & 10mm
IP Protection	IP24
Safety switch	3.0A Normally closed
Thermal protection	✓
Fully potted	n/a
Self priming	n/a

✓ Perfect for... Installation versatility

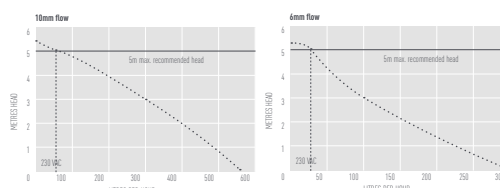
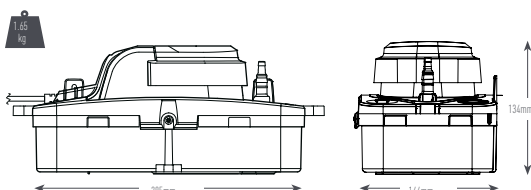

CONDENSATE REMOVAL

ORDERING OF HVAC MATERIALS MADE EASY

CONDENSATE PUMP – MINI BLUE

MINI BLUE PUMP	MINIBLU
BLUE SENSOR	BLUSENSOR



- Max head 8 meters +
- Quiet and low vibration
- Rotary diaphragm technology

KEY FEATURES

- Exceptional performance from a small package
- Proven rotary diaphragm technology as used in the Blue Diamond™
- Flow rate up to 8 litres/hour
- Max head 8 metres+
- Dry suction lift up to 5 metres - self priming
- Very quiet and low vibration
- Power supply 230V. Low power consumption 70 mA

Plot of Flow Rate Against Head

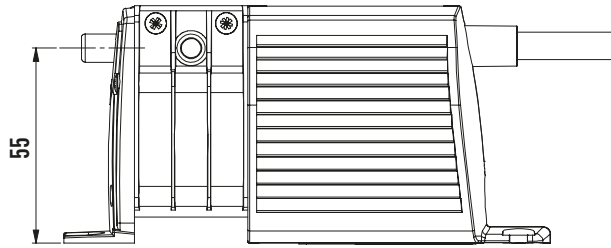
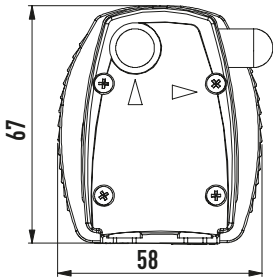
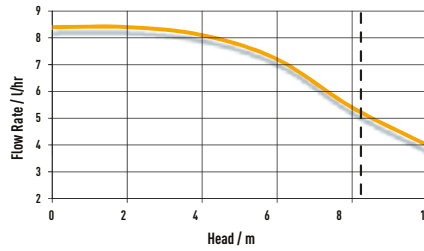

CONDENSOR PUMP – MAXI BLUE

MAXIBLU	MAXI BLUE PUMP
BLUSENSOR	BLUE SENSOR



- Energy Efficient
- Exceptionally quiet and no vibration
- Rotary diaphragm technology
- Can be mounted in any orientation

KEY FEATURES

- Proven rotary diaphragm technology as used in BlueDiamond™
- Flow rate up to 14 l/hr
- Dry suction lift up to 8m
- Self priming
- Energy Efficient
- Exceptionally quiet and no vibration
- Powered by unique water sensors
- Can be mounted in any orientation

Plot of Flow Rate against Head

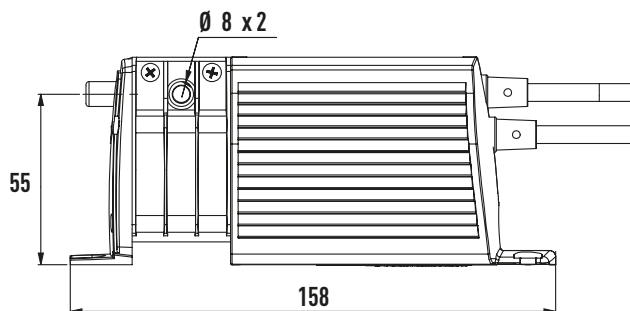
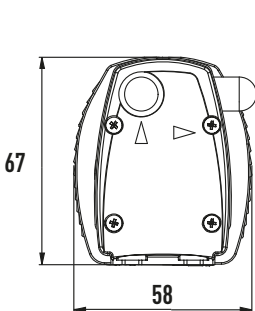
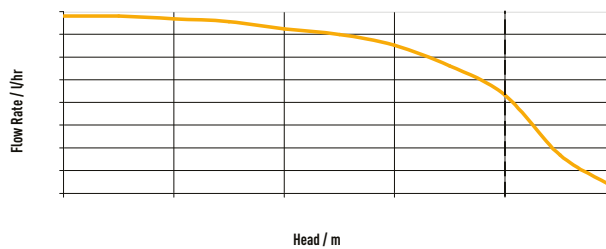

CONDENSATE REMOVAL – MEGA BLUE

MEGA BLUE PUMP	MEGABLU
BLUE SENSOR	BLUSENSOR

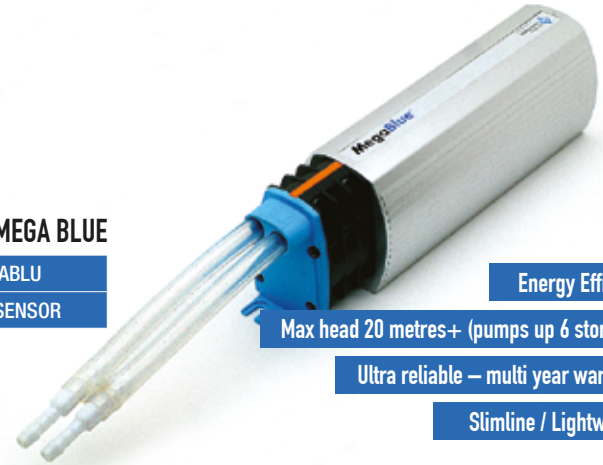

Energy Efficient

Max head 20 metres+ (pumps up 6 storeys!)

Ultra reliable – multi year warranty

Slimline / Lightweight

KEY FEATURES

- Exceptional performance from a small package:-
- Flow rate up to 50 litres/hour
- Max head 20 metres+ (pumps up 6 storeys!)
- Dry suction lift up to 7 metres - self priming
- Very quiet and low vibration
- Power supply 230V/115V - Internally transformed to 12V
- Thermally protected pump

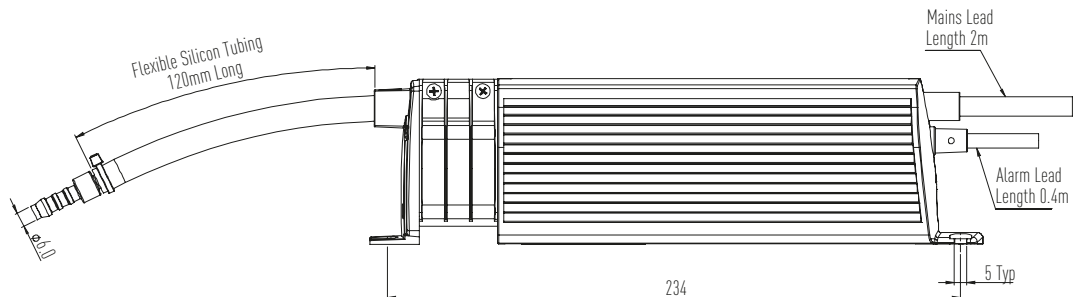
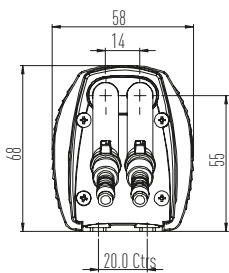
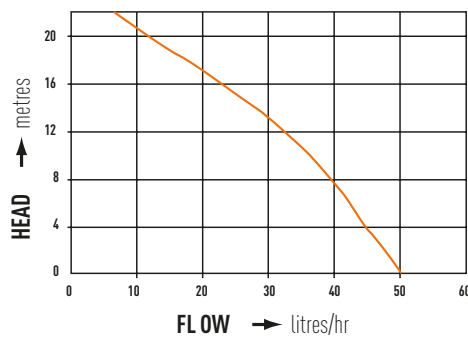

CONDENSER BRACKETS



ALPHA  **SUPPLY**

IN STOCK | ON SITE | ON TIME

ORDERING OF HVAC MATERIALS MADE EASY

Alpha Supply Pty. Ltd.
51 Assembly Dr, Tullamarine VIC 3043
PO Box 132 Tullamarine VIC 3043
P: +61 (0) 3 9445 0848
F: +61 (0) 3 9445 0849
W: www.alphasupply.com.au
E: sales@alphasupply.com.au

WALL BRACKETS

WALL BRACKET PREM-450x350x800 (180kg)	WBP450
WALL BRACKET PREM -550x450x850 (250kg)	WBP550



- Fast & Easy Installation
- Superior Quality
- Built In Level On Backing Plate
- Made From Heavy Duty Steel

ROOF BRACKETS

ROOF BRACKET 150KG	ARB150
--------------------	--------



- Superior Quality
- Made From Heavy Duty Steel

STAINLESS STEEL WALL BRACKETS

STAINLESS STEEL WALL BRACKET PREM - 450X350X800	WBSS450
STAINLESS STEEL WALL BRACKET PREM - 550X350X850	WBSS450



STAINLESS STEEL ROOF BRACKETS

STAINLESS STEEL ROOF BRACKET	ARBSS450
------------------------------	----------



RUBBER MOUNTING BASE

RUBBER BASE (SET 2)-400mm	RB0450
RUBBER BASE (SET 2)-600mm	RB0600
RUBBER BASE (SET 2)-1000mm	RB1000



- Great Absorption Of Vibration & Noise
- For VRF & VRV Condensing Units

PLASTIC MOUNTING BASE

MOUNT BLOCK (SET 2)-450mm	MB0450
MOUNT BLOCK (SET 2)-1000mm	MB1000
MOUNT BLOCK CAP	MBC100



- Stabilized Against UV Rays
- Anti-Vibration Strips
- Fixing Bolts Included

RUBBER MOUNTING FEET

RUBBER MOUNT (SET 4)-50mm	RM050
RUBBER MOUNT (SET 4)-75mm	RM075



- M8 Threaded Rod & Nut
- Isolate, Reduce & Eliminate Vibrations

CONDENSER BRACKETS

ORDERING OF HVAC MATERIALS MADE EASY

READY TO GO SET

READY TO GO SET-470mm	RTG470
READY TO GO SET-635mm	RTG635
READY TO GO SET-780mm	RTG780



Complete With All Strut fixing
Required To Mount A Heavy
Condensing Unit

UNBRACED CANTILEVER BRACKET

CANTILEVER BRACKET UNBRACED-300mm	CA300
CANTILEVER BRACKET UNBRACED-450mm	CA450
CANTILEVER BRACKET UNBRACED-600mm	CA600
CANTILEVER BRACKET UNBRACED-750mm	CA750



BRACED CANTILEVER BRACKET

CANTILEVER BRACKET BRACED-320mm	CAB320
CANTILEVER BRACKET BRACED-470mm	CAB470
CANTILEVER BRACKET BRACED-635mm	CAB635
CANTILEVER BRACKET BRACED-780mm	CAB780



CANTILEVER BRACKET VIBRATION MOUNT

STRUT RUBBER MOUNT (SET 4)	CBVM
----------------------------	------



TOP HAT – GALVANISED

TOP HAT GAL 20GX2.4M 50 x 30 x 20mm	THG5030
TOP HAT GAL 20GX2.4M 50 x 50 x 20mm	THG5050
TOP HAT GAL 20GX2.4M 50 x 70 x 20mm	THG5070

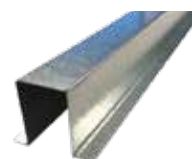

WAFFLEPAD – 10MM & 20MM(SUPER WAFFLE)

WAFFLE PAD 450 X 450MM X 10MM	WP10
SUPER WAFFLE PAD 450 X 450 X 20MM	SWP20



EZI CUT WAFFLEPAD

EZI CUT WAFFLE PAD 10MM	EWP10
-------------------------	-------

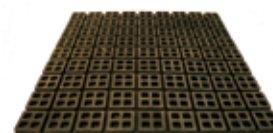

WAFFLE PAD STRIP

WAFFLE PAD 1000 X 100MM X 10MM STRIP **WPSTRIP**



MULTI LAYER PADS

MULTI LAYER PADS 100X100X32 **AVP101032**



For Use in Heavy Mechanical Services Works

Metal layered for extra support

RUBBER FLOOR MOUNTS

RUBBER FLOOR MOUNT-30kg **RFM30**

RUBBER FLOOR MOUNT-50kg **RFM50**



POLYSLABS

POLYSLAB -Medium 885 x 465mm **PS2**

POLYSLAB -Large 1100x650mm **PS3**



LIGHT WEIGHT CONCRETE SLABS

LIGHT WEIGHT CONCRETE SLAB-450mm x 450mm **LWCS4545**

LIGHT WEIGHT CONCRETE SLAB-450mm x 600mm **LWCS4560**

LIGHT WEIGHT CONCRETE SLAB-600mm x 600mm **LWCS6060**



RAPID SET CONCRETE – 20KG

RAPID SET CONCRETE 20KG **RSC**



CONDENSER CAGES

CONDENSER CAGE-Size 1 (1100 x 550 x 600mm) **CC1**

CONDENSER CAGE-Size 2 (1100 x 550 x 800mm) **CC2**

CONDENSER CAGE-Size 3 (1100 x 550 x 1100mm) **CC3**

CONDENSER CAGE-Size 4 (1100 x 550 x 1400mm) **CC4**

BACK PANEL SUIT COND CAGE 1-Size 1 (1100 x 550 x 600mm) **CCBP1**

BACK PANEL SUIT COND CAGE 2-Size 2 (1100 x 550 x 800mm) **CCBP2**

BACK PANEL SUIT COND CAGE 3-Size 3 (1100 x 550 x 1100mm) **CCBP3**

BACK PANEL SUIT COND CAGE 4-Size 4 (1100 x 550 x 1400mm) **CCBP4**

BASE PANEL SUIT COND CAGE- **BASE**



Quick To Assemble

Side & Top Access

Base Plate Available

BIGFOOT SYSTEMS



ALPHA  **SUPPLY**

IN STOCK | ON SITE | ON TIME

ORDERING OF HVAC MATERIALS MADE EASY

Alpha Supply Pty. Ltd.
51 Assembly Dr, Tullamarine VIC 3043
PO Box 132 Tullamarine VIC 3043
P: +61 (0) 3 9445 0848
F: +61 (0) 3 9445 0849
W: www.alphasupply.com.au
E: sales@alphasupply.com.au

BIG FOOT LOCK 'N' LOAD FRAMES

Lock 'N' Load Big Foot A/C Mount Frame	BFLACS
Lock 'N' Load Big Foot A/C Tower Frame Double Stack	BFLACD
Lock 'N' Load Big Foot Extender Kit	BFLACE



- Fast & Easy Installation
- 200MM (8") Feet
- Fully Adjustable Cross Bars
- Supports individual or multiple mini split units
- Galvanized steel frame
- Reinforced plastic connectors
- Anti-Vibration mounts

BIG FOOT STANDARD FRAMES

Big Foot Standard 2 Unit System 1 Meter	BFSF1
Big Foot Standard 4 Unit System 2 Meter	BFSF2
Big Foot Standard 6 Unit System 3 Meter	BFSF3



- Supplied with adjustable leg assemblies
- Feet supplied with rubber mats
- Supplied with clamp kits

BIG FOOT HD BEAMS

Big Foot HD Beam 450mm Feet - 600KG	BFHDB0450
Big Foot HD Beam 600mm Feet - 1000KG	BFHDB1000
Big Foot HD Beam Adjustable 450mm Feet - 600KG	BFHAB0450
Big Foot HD Beam Adjustable 600mm Feet - 1000KG	BFHAB1000



- Non-penetrative high load carrying capacity
- Elevates heavy services off the roof
- Hot dipped galvanised mild steel
- Adjustable height support

BIG FOOT MULTI FOOT

Big Foot Multi Foot 400mm	BFMF400
Big Foot Multi Foot 600mm	BFMF600



- Ridged nylon foot
- Quick & easy installation
- Versatile application
- Accepts a full range of strut sizes
- Supplied with adhered rubber mats for optimum roof protection

PIPE DUCTING



ALPHA  **SUPPLY**

IN STOCK | ON SITE | ON TIME

ORDERING OF HVAC MATERIALS MADE EASY

Alpha Supply Pty. Ltd.
51 Assembly Dr, Tullamarine VIC 3043
PO Box 132 Tullamarine VIC 3043
P: +61 (0) 3 9445 0848
F: +61 (0) 3 9445 0849
W: www.alphasupply.com.au
E: sales@alphasupply.com.au

STRAIGHT PIPE DUCT

PIPE DUCT 2M LENGTH	80mm	PTLT080
PIPE DUCT 2M LENGTH	110mm	PTLT110



FAST CLIP

FAST CLIP	PTFC
-----------	------

This unique fast rail guide along with the FAST CLIP allows you to use a cable tie to strap and keep the drain, suction and liquid lines in place.



JOINER

PIPE DUCT JOINER 80mm	PTJN080
PIPE DUCT JOINER 110mm	PTJN110

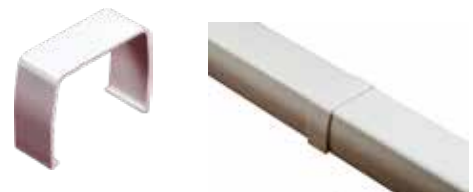

FLAT ELBOW – 90 DEGREE

PIPE DUCT FLAT ELBOW 90 DEG 80mm	PTFE080
PIPE DUCT FLAT ELBOW 90 DEG 110mm	PTFE110

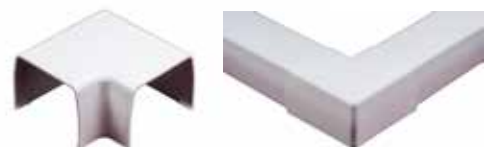

INTERNAL ELBOW – 90 DEGREE

PIPE DUCT INTERNAL CORNER 90 DEG 80mm	PTIN080
PIPE DUCT INTERNAL CORNER 90 DEG 110mm	PTIN110

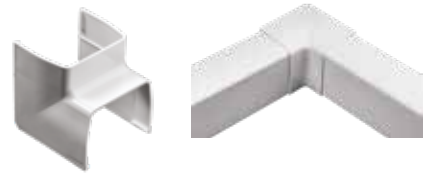

EXTERNAL CORNER ELBOW – 90 DEGREE

PIPE DUCT ETERNAL CORNER 90 DEG 80mm	PTEX080
PIPE DUCT ETERNAL CORNER 90 DEG 110mm	PTEX110



WALL ENTRY

PIPE DUCT WALL ENTRY 80mm	PTWE080
PIPE DUCT WALL ENTRY 110mm	PTWE110



END CAP

PIPE DUCT END CAP 80mm	PTEC080
PIPE DUCT END CAP 110mm	PTEC110

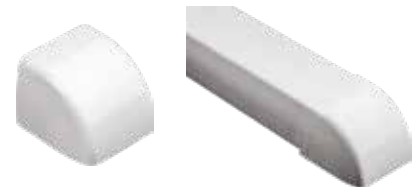

CEILING CAP

PIPE DUCT CEILING CAP 80mm	PTCC080
PIPE DUCT CEILING CAP 110mm	PTCC110



110MM – 80MM REDUCER

110MM-80MM REDUCER	PTR
--------------------	-----

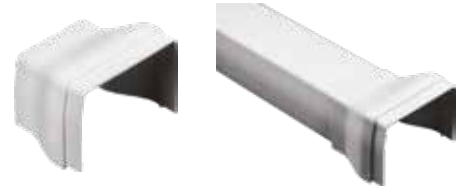

TEE JOINT

110MM TEE JOINT	PCTE
-----------------	------



CEILING CAP

FLEXI JOINT 75MM	FJ075
FLEXI JOINT 100MM	FJ100

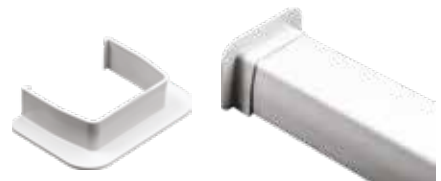

UNSLOTTED ROUND PIPE DUCT

PIPE DUCT ROUND 20M 50mm	PDR50
PIPE DUCT ROUND X 20MTS 65MM	PDR65



FLEXIBLE PIPE COVER

FJ075-FLEXI JOINT 75MM	FJ075
FJ100-FLEXI JOINT 100MM	FJ100



PIPE SUPPORTS



IN STOCK | ON SITE | ON TIME

ORDERING OF HVAC MATERIALS MADE EASY

Alpha Supply Pty. Ltd.
51 Assembly Dr, Tullamarine VIC 3043
PO Box 132 Tullamarine VIC 3043
P: +61 (0) 3 9445 0848
F: +61 (0) 3 9445 0849
W: www.alphasupply.com.au
E: sales@alphasupply.com.au

MAX FIT DOUBLE BOLTED WELDED NUT CLIP

MAX FIX NUT CLIP 20-25mm (Suit 15mm PVC)	MFNC020025
MAX FIX NUT CLIP 26-30mm (Suit 20mm PVC)	MFNC026030
MAX FIX NUT CLIP 32-36mm (Suit 25mm PVC)	MFNC032036
MAX FIX NUT CLIP 38-43mm (Suit 32mm PVC)	MFNC038043
MAX FIX NUT CLIP 47-51mm	MFNC047051
MAX FIX NUT CLIP 53-58mm	MFNC053058
MAX FIX NUT CLIP 60-64mm	MFNC060064
MAX FIX NUT CLIP 68-72mm	MFNC068072
MAX FIX NUT CLIP 75-80mm	MFNC075080
MAX FIX NUT CLIP 81-86mm	MFNC081086
MAX FIX NUT CLIP 87-92mm	MFNC087092
MAX FIX NUT CLIP 93-98mm	MFNC093098
MAX FIX NUT CLIP 99-105mm	MFNC099105
MAX FIX NUT CLIP 107-112mm	MFNC107112
MAX FIX NUT CLIP 113-118mm	MFNC113118
MAX FIX NUT CLIP 119-124mm	MFNC119124
MAX FIX NUT CLIP 125-130mm	MFNC125130
MAX FIX NUT CLIP 129-135mm	MFNC129135
MAX FIX NUT CLIP 132-137mm	MFNC132137
MAX FIX NUT CLIP 138-142mm	MFNC138142
MAX FIX NUT CLIP 159-165mm	MFNC159165



Suits M10 Threaded Rod
Zinc Plated High Strength Design
Ideal For Installing PVC Air Conditioning & Refrigeration Drain
Non Insulated

SINGLE BOLTED ACOUSTIC PIPE CLAMP

NUT CLIP HINGED ACOUSTIC LINED 12-14mm	SBANC1214
NUT CLIP HINGED ACOUSTIC LINED 15-19mm	SBANC1519
NUT CLIP HINGED ACOUSTIC LINED 26-28mm	SBANC2628
NUT CLIP HINGED ACOUSTIC LINED 32-35mm	SBANC3235
NUT CLIP HINGED ACOUSTIC LINED 40-43mm	SBANC4043
NUT CLIP HINGED ACOUSTIC LINED 48-52mm	SBANC4852
NUT CLIP HINGED ACOUSTIC LINED 54-58mm	SBANC5458
NUT CLIP HINGED ACOUSTIC LINED 63-67mm	SBANC6367



Suits M10 Threaded Rod
Insulated With EPDM Rubber Insulation
Single Bolted Design Making It Easy To Install
Other Sizes Available On Request

WELDED DOUBLE BOLTED NUTCLIP

NUT CLIP HD WHITE PVC 40NB	NCPVC040
NUT CLIP HD WHITE PVC 50NB	NCPVC050
NUT CLIP HD WHITE PVC 65NB	NCPVC065
NUT CLIP HD WHITE PVC 80NB	NCPVC080
NUT CLIP HD WHITE PVC 90NB	NCPVC090
NUT CLIP HD WHITE PVC 100NB	NCPVC100
NUT CLIP HD WHITE PVC 150NB	NCPVC150
NUT CLIP HD WHITE PVC 225NB	NCPVC225



Suits M10 Threaded Rod
Extra Heavy Duty For Added Strength
Non Insulated

BBJ METAL SUSPENDER CLIPS

BBJ CLIP METALSize 2 - 3/8 & 5/8	BBJM2
BBJ CLIP METALSize 3 - 1/2 & 7/8	BBJM3
BBJ CLIP METALSize 4 - 5/8 & 1 1/8	BBJM4



Suits M10 Threaded Rod
Ideal to Support Pair Coil
Avoids The Need For Cable Tray
Adjustable Clipping Mechanism

WELDED DOUBLE BOLTED NUTCLIP (Suits Copper Pipe)

NUT CLIP HD BROWN CU 15NB	NCCU015
NUT CLIP HD BROWN CU 20NB	NCCU020
NUT CLIP HD BROWN CU 25NB	NCCU025
NUT CLIP HD BROWN CU 32NB	NCCU032
NUT CLIP HD BROWN CU 40NB	NCCU040
NUT CLIP HD BROWN CU 50NB	NCCU050
NUT CLIP HD BROWN CU 65NB	NCCU065
NUT CLIP HD BROWN CU 80NB	NCCU080
NUT CLIP HD BROWN CU 100NB	NCCU100
NUT CLIP HD BROWN CU 125NB	NCCU125
NUT CLIP HD BROWN CU 150NB	NCCU150



Suits M10 Threaded Rod

Extra Heavy Duty For Added Strength

Ideal For Installing
Copper Class B Copper Pipe

Non Insulated

INSULATED CUSHION CLAMP

CUSHION CLAMP INS ZP 1/4"	ICC06
CUSHION CLAMP INS ZP 3/8"	ICC10
CUSHION CLAMP INS ZP 1/2"	ICC13
CUSHION CLAMP INS ZP 5/8"	ICC16
CUSHION CLAMP INS ZP 3/4"	ICC19
CUSHION CLAMP INS ZP 7/8"	ICC22
CUSHION CLAMP INS ZP 1 1/8"	ICC28
CUSHION CLAMP INS ZP 1 3/8"	ICC35
CUSHION CLAMP INS ZP 1 5/8"	ICC42



Suits 40x40 Slotted Strut

Perfect For Use With
Refrigeration Pipework

QUICK POSITIONING CLIP

QUICK POSITIONING CLIP 1/4"	QPC06
QUICK POSITIONING CLIP 3/8"	QPC10
QUICK POSITIONING CLIP 1/2"	QPC13
QUICK POSITIONING CLIP 5/8"	QPC16
QUICK POSITIONING CLIP 3/4"	QPC19
QUICK POSITIONING CLIP 7/8"	QPC22
QUICK POSITIONING CLIP 1 1/8"	QPC28
QUICK POSITIONING CLIP 1 3/8"	QPC35
QUICK POSITIONING CLIP 1 5/8"	QPC42



Twist and Clip Strut Clip

Easy Installation Into 40x40 and 40 X 20 Strut

Ideal For Air Conditioning and
Refrigeration Installations

Fits Pipes With 9mm Insulation

Helps Dampen Noise and vibrations

THREADED ROD CLIPS

ROD CLIP M106mm 1/4"	TRCL06
ROD CLIP M109mm 3/8"	TRCL10
ROD CLIP M1012mm 1/2"	TRCL13
ROD CLIP M1015mm 5/8"	TRCL16
ROD CLIP M1020mm 3/4"	TRCL19
ROD CLIP M1022mm 7/8"	TRCL22
ROD CLIP M1025mm 1"	TRCL25
ROD CLIP M1028mm 1 1/8"	TRCL28
ROD CLIP M1032mm 1 1/4"	TRCL32
ROD CLIP M1035mm 1 3/8"	TRCL35
ROD CLIP M1038mm 1 1/2"	TRCL38
ROD CLIP M1042mm 1 5/8"	TRCL42
ROD CLIP M1050mm 2"	TRCL50
ROD CLIP M1054mm 2 1/8"	TRCL54



Ratchet Design

Quick Installation and Adjustment

Ideal For Installing Airconditioning
and Refrigeration Drain

Fast Fixing Direct To M10 Rod

Polyblock Ferrule

10MM POLYBLOCK FERRULE SUIT REFRIGERATION TUBE 13MM WALL	PBF1310
13MM POLYBLOCK FERRULE SUIT REFRIGERATION TUBE 13MM WALL	PBF1313
16MM POLYBLOCK FERRULE SUIT REFRIGERATION TUBE 13MM WALL	PBF1316
19MM POLYBLOCK FERRULE SUIT REFRIGERATION TUBE 13MM WALL	PBF1319
22MM POLYBLOCK FERRULE SUIT REFRIGERATION TUBE 13MM WALL	PBF1322
28MM POLYBLOCK FERRULE SUIT REFRIGERATION TUBE 13MM WALL	PBF1328
10MM POLYBLOCK FERRULE SUIT REFRIGERATION TUBE 19MM WALL	PBF1910
13MM POLYBLOCK FERRULE SUIT REFRIGERATION TUBE 19MM WALL	PBF1913
16MM POLYBLOCK FERRULE SUIT REFRIGERATION TUBE 19MM WALL	PBF1916
19MM POLYBLOCK FERRULE SUIT REFRIGERATION TUBE 19MM WALL	PBF1919
22MM POLYBLOCK FERRULE SUIT REFRIGERATION TUBE 19MM WALL	PBF1922
28MM POLYBLOCK FERRULE SUIT REFRIGERATION TUBE 19MM WALL	PBF1928
35MM POLYBLOCK FERRULE SUIT REFRIGERATION TUBE 19MM WALL	PBF1935
15MM POLYBLOCK FERRULE SUIT PLUMBING TUBE 25MM WALL	PBF25015
20MM POLYBLOCK FERRULE SUIT PLUMBING TUBE 25MM WALL	PBF25020
25MM POLYBLOCK FERRULE SUIT PLUMBING TUBE 25MM WALL	PBF25025
32MM POLYBLOCK FERRULE SUIT PLUMBING TUBE 25MM WALL	PBF25032
40MM POLYBLOCK FERRULE SUIT PLUMBING TUBE 25MM WALL	PBF25040
50MM POLYBLOCK FERRULE SUIT PLUMBING TUBE 25MM WALL	PBF25050
65MM POLYBLOCK FERRULE SUIT PLUMBING TUBE 25MM WALL	PBF25065
80MM POLYBLOCK FERRULE SUIT PLUMBING TUBE 25MM WALL	PBF25080
100MM POLYBLOCK FERRULE SUIT PLUMBING TUBE 25MM WALL	PBF25100
125MM POLYBLOCK FERRULE SUIT PLUMBING TUBE 25MM WALL	PBF25125
15MM POLYBLOCK FERRULE SUIT PLUMBING TUBE 38MM WALL	PBF38015
20MM POLYBLOCK FERRULE SUIT PLUMBING TUBE 38MM WALL	PBF38020
25MM POLYBLOCK FERRULE SUIT PLUMBING TUBE 38MM WALL	PBF38025
32MM POLYBLOCK FERRULE SUIT PLUMBING TUBE 38MM WALL	PBF38032
40MM POLYBLOCK FERRULE SUIT PLUMBING TUBE 38MM WALL	PBF38040
50MM POLYBLOCK FERRULE SUIT PLUMBING TUBE 38MM WALL	PBF38050
65MM POLYBLOCK FERRULE SUIT PLUMBING TUBE 38MM WALL	PBF38065
80MM POLYBLOCK FERRULE SUIT PLUMBING TUBE 38MM WALL	PBF38080
100MM POLYBLOCK FERRULE SUIT PLUMBING TUBE 38MM WALL	PBF38100
125MM POLYBLOCK FERRULE SUIT PLUMBING TUBE 38MM WALL	PBF38125
15MM POLYBLOCK FERRULE SUIT PLUMBING TUBE 50MM WALL	PBF50015
20MM POLYBLOCK FERRULE SUIT PLUMBING TUBE 50MM WALL	PBF50020
25MM POLYBLOCK FERRULE SUIT PLUMBING TUBE 50MM WALL	PBF50025
32MM POLYBLOCK FERRULE SUIT PLUMBING TUBE 50MM WALL	PBF50032
40MM POLYBLOCK FERRULE SUIT PLUMBING TUBE 50MM WALL	PBF50040
50MM POLYBLOCK FERRULE SUIT PLUMBING TUBE 50MM WALL	PBF50050
65MM POLYBLOCK FERRULE SUIT PLUMBING TUBE 50MM WALL	PBF50065
80MM POLYBLOCK FERRULE SUIT PLUMBING TUBE 50MM WALL	PBF50080
100MM POLYBLOCK FERRULE SUIT PLUMBING TUBE 50MM WALL	PBF50100
125MM POLYBLOCK FERRULE SUIT PLUMBING TUBE 50MM WALL	PBF50125



- Quick and Easy Installation
- Manufactured From Durable Material
- Refrigeration Pipe Sizes Can Be Manufactured By Alpha Supply

BBJ PLASTIC SUSPENDER CLIPS

BBJ CLIP PLASTIC Size 2 - 3/8 & 5/8	BBJP2
BBJ CLIP PLASTIC Size 3 - 1/2 & 7/8	BBJP3
BBJ CLIP PLASTIC Size 4 - 5/8 & 1 1/8	BBJP4



- Suits M10 Threaded Rod
- Ideal to Support Pair Coil
- Avoids The Need For Cable Tray
- Zinc Coated To Avoid Corrosion
- Meet Fire Regulations

STRUT CLIPS

STRUT CLIP HD-38mm	SCDH038
STRUT CLIP HD-35mm	SCHD035
STRUT CLIP HD-43mm	SCHD043
STRUT CLIP HD-51mm	SCHD051
STRUT CLIP HD-57mm	SCHD057
STRUT CLIP HD-64mm	SCHD064
STRUT CLIP HD-70mm	SCHD070
STRUT CLIP HD-76mm	SCHD076
STRUT CLIP HD-83mm	SCHD083
STRUT CLIP HD-89mm	SCHD089
STRUT CLIP HD-95mm	SCHD095
STRUT CLIP HD-98mm	SCHD098
STRUT CLIP HD-102mm	SCHD102
STRUT CLIP HD-105mm	SCHD105
STRUT CLIP HD-108mm	SCHD108
STRUT CLIP HD-111mm	SCHD111
STRUT CLIP HD-114mm	SCHD114
STRUT CLIP HD-117mm	SCHD117
STRUT CLIP HD-121mm	SCHD121
STRUT CLIP HD-127mm	SCHD127
STRUT CLIP HD-132mm	SCHD132
STRUT CLIP HD-133mm	SCHD133
STRUT CLIP HD-140mm	SCHD140
STRUT CLIP HD-152mm	SCHD152
STRUT CLIP HD-159mm	SCHD159
STRUT CLIP HD-165mm	SCHD165
STRUT CLIP HD-171mm	SCHD171
STRUT CLIP HD-178mm	SCHD178
STRUT CLIP HD-191mm	SCHD191
STRUT CLIP HD-203mm	SCHD203
STRUT CLIP HD-228mm	SCHD228
STRUT CLIP HD 250MM	SCHD250



Designed and Manufactured To Be Installed Into Strut



Ferrule Supplied Separately

PIPE SADDLE TO SUIT COPPER PIPE

NYLON COATED SADDLE SUIT 15MM	SADNY15
NYLON COATED SADDLE SUIT 20MM	SADNY20
NYLON COATED SADDLE SUIT 25MM	SADNY25
NYLON COATED SADDLE SUIT 32MM	SADNY32
NYLON COATED SADDLE SUIT 40MM	SADNY40
NYLON COATED SADDLE SUIT 50MM	SADNY50



PIPE SADDLE – POWDERCOATED

P/COAT SADDLE SUIT PVC-15mm	SADPVC015
P/COAT SADDLE SUIT PVC-20mm	SADPVC020
P/COAT SADDLE SUIT PVC-25mm	SADPVC025
P/COAT SADDLE SUIT PVC-32mm	SADPVC032
P/COAT SADDLE SUIT PVC-40mm	SADPVC040
P/COAT SADDLE SUIT PVC-50mm	SADPVC050



Manufactured To Suit Pressure Pipe Drain Sizes

DRAIN WASTE VENT (DWV) SADDLE

DWV SADDLE-40mm	DWVSAD040
DWV SADDLE-65mm	DWVSAD065
DWV SADDLE-80mm	DWVSAD080
DWV SADDLE-100mm	DWVSAD100



STAND OFF BRACKET & CLIP HEAD

STAND OFF BRACKET	SOBRAC
CLIP HEAD SUIT PVC 15mm	CHPVC15
CLIP HEAD SUIT PVC 20mm	CHPVC20
CLIP HEAD SUIT PVC 25mm	CHPVC25
CLIP HEAD SUIT PVC 32mm	CHPVC32



HALF SADDLE – ZINC PLATE

HALF SADDLE ZP 16mm	CONHS16
HALF SADDLE ZP 20mm (SUITS ELECTRICAL CONDUIT 20mm)	CONHS20
HALF SADDLE ZP 25mm (SUITS ELECTRICAL CONDUIT 25mm)	CONHS25
HALF SADDLE ZP 32mm	CONHS32
HALF SADDLE ZP 50mm	CONHS50



FULL SADDLE – ZINC PLATE

FULL SADDLE ZP 25mm	CONF25
FULL SADDLE ZP 32mm	CONF32



CLEVIS HANGER

CLEVIS HANGER HDG M10 (M8 BOLT)	CHGM10
---------------------------------	--------



FASTENERS AND FIXINGS



IN STOCK | ON SITE | ON TIME

ORDERING OF HVAC MATERIALS MADE EASY

Alpha Supply Pty. Ltd.
51 Assembly Dr, Tullamarine VIC 3043
PO Box 132 Tullamarine VIC 3043
P: +61 (0) 3 9445 0848
F: +61 (0) 3 9445 0849
W: www.alphasupply.com.au
E: sales@alphasupply.com.au

THREADED ROD

THREADED ROD ZP 3M-8mm	TRZ08
THREADED ROD ZP 3M-10mm	TRZ10
THREADED ROD ZP 3M-12mm	TRZ12
THREADED ROD ZP 3M-20mm	TRZ20



Available In Galvanised On Request

Available In Stainless Steel On Request

SLOTTED ANGLE

SAZ3030-A0501301-SLOTTED ANGLE 3M-30mm x 30mm x 2.5mm	SAZ3030
SAZ4040-A0501302-SLOTTED ANGLE 3M-40mm x 40mm x 2.5mm	SAZ4040
SAZ5050-A0501303-SLOTTED ANGLE 3M-50mm x 50mm x 2.5mm	SAZ5050



SOLID ANGLE (DURAGAL) – 6 Meter Lengths

SOLID ANGLE 6M40mm x 40mm x 2.5mm	DGA640
SOLID ANGLE 6M50mm x 50mm x 2.5mm	DGA650



SLOTTED STRUT

SLOTTED STRUT GB 40X40X2.5 3m	SSZH40403
SLOTTED STRUT GB 40X40X2.5 6m	SSZH40406
SLOTTED STRUT LD GB 40X40X1.6 3m	SSZL40403
SLOTTED STRUT LD GB 40X40X1.6 6m	SSZL40406
SLOTTED STRUT GB 40X20X2.5 3m	SSZH40203
SLOTTED STRUT GB 40X20X2.5 6m	SSZH40206
SLOTTED STRUT LD GB 40X20X1.6 3m	SSZL40203
SLOTTED STRUT LD GB 40X20X1.6 6m	SSZL40206
SLOTTED STRUT HDG 40X40X2.5 3m	SSGH40403
SLOTTED STRUT HDG 40X40X2.5 6m	SSGH40406
SLOTTED STRUT BACK TO BACK 80X40X2.5 6m	SSZBB6



SOLID STRUT

SOLID STRUT 40X40X2.5 3m	USZH40403
SOLID STRUT 40X40X2.5 6m	USZH40406
SOLID STRUT HDG 40X40X2.5 3m	USGH40403
SOLID STRUT HDG 40X40X2.5 6m	USGH40406



LIGHT GAUGE GAL ANGLE (SHEETMETAL ANGLE)

ANGLE GAL 24GX2.4M 30mm x 30mm	ANGGAL30
ANGLE GAL 24GX2.4M 40mm x 40mm	ANGGAL40
ANGLE GAL 24GX2.4M50mm x 50mm	ANGGAL50



Ideal For Use With Cushion Boxes

TOP HAT – GALVANISED

TOP HAT GAL 20GX2.4M 50 x 30 x 20mm	THG5030
TOP HAT GAL 20GX2.4M 50 x 50 x 20mm	THG5050
TOP HAT GAL 20GX2.4M 50 x 70 x 20mm	THG5070

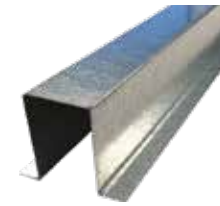

CANTILEVER BRACKETS

CANTILEVER BRACKET UNBRACED-300mm	CA300
CANTILEVER BRACKET UNBRACED-450mm	CA450
CANTILEVER BRACKET UNBRACED-600mm	CA600
CANTILEVER BRACKET UNBRACED-750mm	CA750
CANTILEVER BRACKET UNBRACED-900mm	CA900
CANTILEVER BRACKET BRACED-320mm	CAB320
CANTILEVER BRACKET BRACED-470mm	CAB470
CANTILEVER BRACKET BRACED-635mm	CAB635
CANTILEVER BRACKET BRACED-780mm	CAB780
CANTILEVER BRACKET BRACED-935mm	CAB935
CANTILEVER BRACKET BACK TO BACK-750mm	CABB750



STRUT NUT – NO SPRING

STRUT NUT NO SPRING ZP-M10	SNZ10
----------------------------	-------



STRUT NUT – SHORT SPRING

STRUT NUT SHORT SPRING ZP-M10	SNSZ10
STRUT NUT SHORT STRING HDG-M10	SNSH10



STRUT NUT LONG SPRING

STRUT NUT LONG SPRING ZP-M10	SNLZ10
STRUT NUT LONG SPRING HDG-M10	SNLH10
STRUT NUT LONG SPRING ZP-M12	SNLZ12



SPEED NUT

SPEED NUT M10	SNM10
---------------	-------

Speed nuts are a quicker alternative to using a standard strut nut.

Installation is simple. After inserting the speed nut in the strut, put pressure on the nut causing it to turn to the right and engage into the strut. De-installation simply requires the Speed Nut to be turned to the left and pulled free from the strut. Installation and de-installation does not require tools and can be repeated several times.



STRUT BASE PLATES

BASE PLATE 100X100X40X40	BP1
BASE PLATE 150X150X40X40	BP2
BASE PLATE 150X150X40X80	BP3



ANGLE BRACKETS

ANGLE BRACKET 90 DEG 2 HOLE	SAB902
ANGLE BRACKET 90 DEG 3 HOLE	SAB903
ANGLE BRACKET 90 DEG 4 HOLE	SAB904



FLAT PLATE FITTINGS

3 HOLE FLAT CORNER PLATE	FP3H
4 HOLE FLAT PLATE	FP4H
4 HOLE FLAT TEE BRACKET	4HTEE



SQUARE WASHERS

SQUARE WASHER 40X40 M10 3mm	SW40M103
SQUARE WASHER 40X40 M10 6mm	SW40M106



ANGLE BRACKET – WIDE TEE

ANGLE BRACKET WIDE TEE	ABWT
------------------------	------



ANGLE BRACKETS

EXTERNAL ANGLE BRACKET 45 DEG	ABEX45
INTERNAL ANGLE BRACKET 45 DEG	ABIN45



ANGLE BRACKETS – 45 DEGREE

ANGLE STRUT BRACE 45 DEG	ASB45
--------------------------	-------



STRUT WINDOW BRACKETS

STRUT WINDOW BRACKET 40X40	WB4040
----------------------------	--------



STRUT JOINERS

INTERNAL JOINER 40X40	INJ4040
EXTERNAL JOINER	EXJ4040



STRUT PLASTIC END CAPS

PLASTIC END CAP 40X20	PEC20
PLASTIC END CAP 40X40	PEC40



STRUT PLASTIC END CAPS

STRUT CLOSURE STRIP GREY	SCS3MG
--------------------------	--------



HEX NUTS

HEX NUT ZP -M8	HNZPM08
HEX NUT ZP -M10	HNZPM10
HEX NUT ZP -M12	HNZPM12
HEX NUT M8 -M8	HNHDGM08
HEX NUT M10 -M10	HNHDGM10
HEX NUT M12 -M12	HNHDGM12



Also Available In other sizes & galvanised

FLANGE NUTS – (WIZZ NUTS)

FLANGE NUT ZP – M10	FNZPM10
---------------------	---------



NYLOC NUT – ZINC PLATE

NYLOC NUT ZP -M10	NNZPM10
-------------------	---------



RETROFIT HEX NUT

HEX NUT RETROFIT	RHNM10
------------------	--------



T-NUT

TNUT1040	TNUT1040
----------	----------



WEDGE NUT

WEDGE NUT -M10	WNM10
----------------	-------



FLAT WASHER

FLAT WASHER ZP -M6	FWZPM06
FLAT WASHER ZP -M8	FWZPM08
FLAT WASHER ZP -M10	FWZPM10
FLAT WASHER ZP -M12	FWZPM12
FLAT WASHER HDG -M8	FWHDGM08
FLAT WASHER HDG -M10	FWHDGM10
FLAT WASHER HDG -M12	FWHDGM12



FLAT WASHER – MUDGAURD

MUD WASHER ZP M6	MWZPM06
MUD WASHER ZP M8	MWZPM08
MUD WASHER ZP M10	MWZPM10
MUD WASHER ZP M12	MWZPM12



FLAT WASHER – PENNY

PENNY WASHER ZP M8	PWZPM08
PENNY WASHER ZP M10	PWZPM10



CUPHEAD BOLTS & NUTS – ZINC PLATE

CUPHEAD BOLT & NUT	8x20	CBNZ08020
CUPHEAD BOLT & NUT	8x25	CBNZ08025
CUPHEAD BOLT & NUT	8x30	CBNZ08030
CUPHEAD BOLT & NUT	8x40	CBNZ08040
CUPHEAD BOLT & NUT	10x25	CBNZ10025
CUPHEAD BOLT & NUT	10x30	CBNZ10030
CUPHEAD BOLT & NUT	10x40	CBNZ10040



HEX BOLT & NUT – ZINC PLATE

HEX BOLT & NUT ZP	M8 x 20	HBNZ08020
HEX BOLT & NUT ZP	M8 x 25	HBNZ08025
HEX BOLT & NUT ZP	M8 x 30	HBNZ08030
HEX BOLT & NUT ZP	M8 x 35	HBNZ08035
HEX BOLT & NUT ZP	M8 x 40	HBNZ08040
HEX BOLT & NUT ZP	M10 x 25	HBNZ10025
HEX BOLT & NUT ZP	M10 x 30	HBNZ10030
HEX BOLT & NUT ZP	M10 x 35	HBNZ10035
HEX BOLT & NUT ZP	M10 x 40	HBNZ10040



HEX BOLT & NUT – GALVANISED

HEX BOLT & NUT GAL	M8 x 20	HBNG08020
HEX BOLT & NUT GAL	M10 x 25	HBNG10025
HEX BOLT & NUT GAL	M10 x 30	HBNG10030
HEX BOLT & NUT GAL	M10 x 35	HBNG10035
HEX BOLT & NUT GAL	M10 x 40	HBNG10040
HEX BOLT & NUT GAL	M10 x 50	HBNG10050
HEX BOLT & NUT GAL	M12 x 25	HBNG12025
HEX BOLT & NUT GAL	M16 x 40	HBNG16040
HEX BOLT & NUT GAL	M16 x 75	HBNG16075
HEX BOLT & NUT GAL	M16 x 120	HBNG16120
HEX BOLT & NUT GAL	M16 x 140	HBNG16140
HEX BOLT & NUT GAL	M20 x 50	HBNG20050



SET SCREW

SET SCREW ZP M10x20	SSZ10020
SET SCREW ZP M10x25	SSZ10025
SET SCREW ZP M10x30	SSZ10030
SET SCREW ZP M10x35	SSZ10035
SET SCREW ZP M10x40	SSZ10040
SET SCREW ZP M10x65	SSZ10065



VERTICAL MOUNTING PLATE

VERTICAL MOUNTING PLATE-M10	VMP10
-----------------------------	-------



CENTRE MOUNTING PLATE

CENTRE MOUNTING PLATE	CMP10
-----------------------	-------



HORIZONTAL MOUNTING PLATE

HORIZONTAL MOUNTING PLATE-M10	HMP10
-------------------------------	-------



HEX COUPLER – ZINC PLATE

HEX COUPLER ZP-M10	HCM10
HEX COUPLER ZP-M12	HCM12



PURLIN HANGER – HEAVY DUTY

PURLIN HANGER HD-M10	PH10
PURLIN HANGER HD-M12	PH12



PURLIN HANGER – LIGHT DUTY

PURLIN HANGER - LIGHT DUTY **PLDM10**



D PURLIN CLIP

DPURLIN **DPURLIN**



PURLIN CLAMP

2200 PURLIN CLAMP ZP **PC2200**



DUCT HANGING SUPPORT BOLT

DUCT HANGER BOLT M10 **DHBM10**



DUCT HANGING SUPPORT CORNER BRACKET

DUCT CORNER BRACKET **DCB**



DUCT HANGING SUPPORT Z BRACKET

Z BRACKET **ZBRACKET**



UNIVERSAL JOINT – M10

UNIVERSAL JOINT UGM10	UJM10
-----------------------	-------



POST HEAD

POST HEAD M10	PHM10
---------------	-------



BEAM CLAMP

BEAM CLAMP ZP-M10	BCZ10
BEAM CLAMP ZP-M12	BCZ12



VERTIGO CONCRETE

VERTIGO CONCRETE	VG C100
VERTIGO CONCRETE 500PK BUCKET	VG C500BK



VERTIGO TIMBER

VERTIGO TIMBER Side M10	VG TH
VERTIGO TIMBER Vertical M10x25	VG TS25
VERTIGO TIMBER Vertical M10x50	VG TS50



VERTIGO STEEL

VERTIGO STEEL HORIZONTAL (SIDE) M10	VG SH
VERTIGO STEEL HANGER VERTICAL M10	VG SS



VERTIGO DRIVERS

VERTIGO DRIVER CONCRETE	VDCON
VERTIGO DRIVER TIMBER/STEEL	VDTS



DROP IN ANCHOR – ZINC PLATED

DROP IN ANCHOR M8 x 30	DM08
DROP IN ANCHOR LIPPED M10 x 30	DLP1030
DROP IN ANCHOR LIPPED M10 x 40 Lipped	DLP1040
DROP IN ANCHOR LIPPED M12 x 50mm	DLP1050
DROP IN ANCHOR LIPPED M10 x 30 Bucket 500 Qty	DLPM1030BK



DROP IN SETTING TOOL

DROP IN SETTING TOOL LIP M10	DAI0M10010
------------------------------	------------



DROP IN SETTING TOOLKIT

DROP IN SETTING TOOLKIT M10X30	DISTKIT
--------------------------------	---------



SLEEVE ANCHOR – ZINC PLATED

SLEEVE ANCHOR ZY8 x 40	SANZ08040
SLEEVE ANCHOR ZY10 x 40	SANZ10040
SLEEVE ANCHOR ZY10 x 50	SANZ10050
SLEEVE ANCHOR ZY10 x 60	SANZ10060
SLEEVE ANCHOR ZY10 x 75	SANZ10075
SLEEVE ANCHOR ZY12 x 60	SANZ12060
SLEEVE ANCHOR ZY12 x 75	SANZ12075
SLEEVE ANCHOR ZY12 x 100	SANZ12100



SLEEVE ANCHOR – GALVANISED

SLEEVE ANCHOR GAL8 x 40	SAG08040
SLEEVE ANCHOR GAL10 x 40	SAG10040
SLEEVE ANCHOR GAL10 x 50	SAG10050
SLEEVE ANCHOR GAL10 x 60	SAG10060
SLEEVE ANCHOR GAL10 x 75	SAG10075
SLEEVE ANCHOR GAL12 x 60	SAG12060
SLEEVE ANCHOR ZY12 x 75	SANZ12075
SLEEVE ANCHOR ZY12 x 100	SANZ12100



SCREW BOLT

SCREW BOLT GALM10 x 60mm	SBG10060
SCREW BOLT GALM10 x 75mm	SBG10075
SCREW BOLT GALM12 x 75mm	SBG12075
SCREW BOLT GALM16 x 100mm	SBG16100



CONCRETE TAPPER

CONCRETE TAPPER HEX HEAD-6.5 x 45mm	CTH45
CONCRETE TAPPER HEX HEAD-6.5 x 58mm	CTH58
CONCRETE TAPPER HEX HEAD-6.5 x 70mm	CTH70
CONCRETE TAPPER HEX HEAD-6.5 x 83mm	CTH83
CONCRETE TAPPER HEX HEAD-6.5 x 100mm	CTH100



NYLON KNOCK IN

NYLON KNOCK IN 5 x 25mm	NNR05025
NYLON KNOCK IN 5 x 40mm	NNR05040
NYLON KNOCK IN 6.5 x 25mm	NNR65025
NYLON KNOCK IN 6.5 x 38mm	NNR65038
NYLON KNOCK IN 6.5 x 50mm	NNR65050



METAL DRIVE ANCHOR

METAL DRIVE ANCHOR 5 x22mm	MDA0522
METAL DRIVE ANCHOR 6.5 x20mm	MDA6520
METAL DRIVE ANCHOR 6.5 x25mm	MDA6525
METAL DRIVE ANCHOR 6.5 x32mm	MDA6532
METAL DRIVE ANCHOR 6.5 x38mm	MDA6538
METAL DRIVE ANCHOR 6.5 x50mm	MDA6550



TIRE WIRE STRIKE ANCHOR – ZINK PLATED

TIE WIRE STRIKE ANCHOR -5mm	TWSA50
TIE WIRE STRIKE ANCHOR -6.5mm	TWSA65



FRAMED WALL PLUGS

WALL PLUG 38MMBlue 38mm	WPPVC38B
WALL PLUG 38MMGreen 38mm	WPPVC38G
WALL PLUG 38MMRed 38mm	WPPVC38R



HEX HEAD DRILLPOINT SCREW – GALVANISED

HEX HEAD SD SCREW GAL 10-16x16	HXSDG101616
HEX HEAD SD SCREW GAL 10-16x25	HXSDG101625
HEX HEAD SD SCREW GAL 12-14x20	HXSDG121420
HEX HEAD SD SCREW GAL 12-14x35	HXSDG121435
HEX HEAD SD SCREW GAL 12-14x45	HXSDG121445
HEX HEAD SD SCREW GAL 12-14x55	HXSDG121455
HEX HEAD SD SCREW GAL 12-14x65	HXSDG121465
HEX HEAD SD SCREW GAL 14-10x25	HXSDG141025



HEX HEAD DRILLPOINT SCREW – ZINC CLEAR

HEX HEAD SD SCREW ZC 10-16x16	HXSDZC101616
HEX HEAD SD SCREW ZC 10-16x25	HXSDZC101625



HEX HEAD DRILLPOINT SCREW – ZINC YELLOW

HEX HEAD SD SCREW ZY ZY 10-16x16	HXSDZY101616
HEX HEAD SD SCREW ZY ZY 10-16x25	HXSDZY101625
HEX HEAD SD SCREW ZY ZY 12-14x20	HXSDZY121420



SERIES 500 DRILLPOINT SCREWS – GALVANISED

HEX HEAD SD SCREW 500 GAL 12x32	HXSD5G1232
HEX HEAD SD SCREW 500 GAL 12x50	HXSD5G1250
HEX HEAD SD SCREW 500 GAL 12x65	HXSD5G1265



HEX HEAD DRILLPOINT SCREWS WITH NEO WASHER – GALVANISED

HEX HEAD DP SCREW GAL NEO 10x16	HXSDGW1016
HEX HEAD DP SCREW GAL NEO 10x25	HXSDGW1025
HEX HEAD DP SCREW GAL NEO 12x35	HXSDGW1235
HEX HEAD DP SCREW GAL NEO 12x45	HXSDGW1245
HEX HEAD DP SCREW GAL NEO 12x55	HXSDGW1255
HEX HEAD DP SCREW GAL NEO 12x65	HXSDGW1265



HEX HEAD TYPE 17 SCREWS WITH NEO – GALVANISED (ROOFING SCREWS)

HEX HEAD TYPE 17 SCREW C4 NEO 12gx45mm	T17HXC4W1245
HEX HEAD TYPE 17 SCREW C4 NEO 12gx50mm	T17HXC4W1250
HEX HEAD TYPE 17 SCREW C4 NEO 14gx65mm	T17HXC4W1465
HEX HEAD TYPE 17 SCREW C4 NEO 14gx75mm	T17HXC4W1475



HEX HEAD TYPE 17 SCREWS – ZINC PLATED

HEX HEAD TYPE 17 SCREW ZY 12gx25mm	T17HXZY1225
HEX HEAD TYPE 17 SCREW ZY 12gx40mm	T17HXZY1240
HEX HEAD TYPE 17 SCREW ZY 12gx50mm	T17HXZY1250
HEX HEAD TYPE 17 SCREW ZY 12gx65mm	T17HXZY1265



PANHEAD DRILLPOINT SCREW – ZINC PLATED

PANHEAD DRILLPOINT 12MM - ZINC PLATE	PHDPZY12
PANHEAD DRILLPOINT 16MM - ZINC PLATE	PHDPZY16



PANHEAD NEEDLE POINT SCREW – ZINC YELLOW

PANHEAD NEEDLE POINT ZINC PLATE - 12MM	PHNPZY12
PANHEAD NEEDLE POINT ZINC PLATE - 20MM	PHNPZY20
PANHEAD NEEDLE POINT ZINC PLATE - 25MM	PHNPZY25
PANHEAD NEEDLE POINT ZINC PLATE - 30MM	PHNPZY30
PANHEAD NEEDLE POINT ZINC PLATE - 40MM	PHNPZY40
PANHEAD NEEDLE POINT ZINC PLATE - 50MM	PHNPZY50



BUTTONHEAD DRILLPOINT SCREW – GALVANISED

BUTTONHEAD DRILL SCREW GAL-8g x 12mm	BHDPG12
BUTTONHEAD DRILL SCREW GAL-8g x 16mm	BHDPG16
BUTTONHEAD DRILL SCREW GAL-8gx20mm	BHDPG20
BUTTONHEAD DRILL SCREW GAL-8gx25mm	BHDPG25
BUTTONHEAD DRILL SCREW GAL-8gx32mm	BHDPG32



BUTTONHEAD DRILLPOINT SCREW – ZINK PLATED

BUTTONHEAD DRILL SCREW ZY -8g x 12mm	BHDPZ12
BUTTONHEAD DRILL SCREW ZY -8g x 16mm	BHDPZ16
BUTTONHEAD DRILL SCREW ZY -8g x 20mm	BHDPZ20
BUTTONHEAD DRILL SCREW ZY -8-18x25mm	v
BUTTONHEAD DRILL SCREW ZY -8-18x32mm	BHDPZ32



FLAT TOP DRILLPOINT SCREW

FLAT TOP DRILL SCREW 10-16X16MM-ZP	FTDP16ZY
FLAT TOP DRILL SCREW 10-16X16MM-GAL	FTDP16C3



BUTTONHEAD NEEDLEPOINT SCREW – GALVANISED

BUTTONHEAD NEEDLE SCREW GAL 12MM	BHNPG12
BUTTONHEAD NEEDLE SCREW GAL 16MM	BHNPG16
BUTTONHEAD NEEDLE SCREW GAL-8-18x20mm	BHNPG20
BUTTONHEAD NEEDLE SCREW GAL-8-18x25mm	BHNPG25
BUTTONHEAD NEEDLE SCREW GAL-8-18x32mm	BHNPG32



BUTTONHEAD NEEDLEPOINT SCREW – ZINK PLATED

BUTTONHEAD NEEDLE SCREW ZY-8-18x12mm	BHNpz12
BUTTONHEAD NEEDLE SCREW ZY-8-18x16mm	BHNpz16
BUTTONHEAD NEEDLE SCREW ZY-8-18x20mm	BHNpz20
BUTTONHEAD NEEDLE SCREW ZY-8-18x25mm	BHNpz25
BUTTONHEAD NEEDLE SCREW ZY-8-18x32mm	BHNpz32



BUGLE HEAD SCREW – ZINK PLATED

BUGLE HEAD SCREW -20mm	BHS20
BUGLE HEAD SCREW -25mm	BHS25
BUGLE HEAD SCREW -32mm	BHS32
BUGLE HEAD SCREW -35mm	BHS35
BUGLE HEAD SCREW -41mm	BHS41
BUGLE HEAD SCREW -45mm	BHS45



CHIPBOARD SCREW – ZINK PLATED

CHIPBOARD SCREW ZY 8g x 20mm	CBSZY08020
CHIPBOARD SCREW ZY 8g x 25mm	CBSZY08025
CHIPBOARD SCREW ZY 8g x 32mm	CBSZY08032
CHIPBOARD SCREW ZY 8gx35mm	CBSZY08035
CHIPBOARD SCREW ZY 8gx40mm	CBSZY08040
CHIPBOARD SCREW ZY 8gx45mm	CBSZY08045
CHIPBOARD SCREW ZY 8gx50mm	CBSZY08050
CHIPBOARD SCREW ZY 8gx57mm	CBSZY08057
CHIPBOARD SCREW ZY 10gx65mm	CBSZY10065
CHIPBOARD SCREW ZY 10gx75mm	CBSZY10075
CHIPBOARD SCREW ZY 10gx100mm	CBSZY10100
CHIPBOARD SCREW ZY 10gx125mm	CBSZY10125
CHIPBOARD SCREW ZY 10gx150mm	CBSZY10150



ZIPPIT HOLLOW WALL ANCHOR

ZIPPIT ANCHOR METAL	ZIPMET
ZIPPIT ANCHOR NYLON	ZIPNYL



HOLLOW WALL ANCHOR – ZINC PLATED

HOLLOW WALL ANCHOR 1/8 10 12MM (100PK)	HWA
HOLLOW WALL ANCHOR HEAVY DUTY TOOL	HWAHDT



WALL DOG SCREWS – ZINC PLATED

WALL DOG ZP 32MM (20PK)	WD2032
-------------------------	--------



SPRING TOGGLE – ZINK PLATED

SPRING TOGGLE **RHST31650**



TOGGLE PLASTIC STRAP

PLASTIC M6 TOGGLE STRAP **PTSM06**



TDF/TDC CLAMP COMPLETE WITH NYLON BOLT

TDF/TDC CLAMP NYLON BOLT **TDFTDC**



NYLON SET SCREW – M10

NYLON BOLT - M10 x 30 **NSSM1030**

NYLON BOLT - M10 x 40 **NSSM1040**



NYLON NUT - M10

NYLON NUT - M10 **NHNM10**



RIVETS

RIVET ALUMINIUM-4-2	AS42
RIVET ALUMINIUM-4-3	AS43
RIVET ALUMINIUM-4-4	AS44
RIVET ALUMINIUM-4-5	AS45
RIVET ALUMINIUM-4-6	AS46
RIVET ALUMINIUM-4-8	AS48
RIVET ALUMINIUM-5-6	AS56
RIVET ALUMINIUM BLACK-4-4	ASB44B
RIVET ALUMINIUM WHITE-4-4	ASW44
RIVET STEEL-4-2	SS42
RIVET STEEL-4-4	SS44



CEILING HANGER CLIP

CEILING HANGER CLIP	CHC100
---------------------	--------



J CLEAT

J CLEAT -Long	CLEATL
J CLEAT-Short	CLEATS



FLANGE – 6 METER LENGTHS

FLANGE 6M-20mm	FLANGE20
FLANGE 6M-35mm	FLANGE35



FLANGE CORNERS

FLANGE CORNER-20mm	FCRN20
FLANGE CORNER-35mm	FCRN35



REGISTER SPRINGS

REGISTER SPRING-10 x 75 Unplated length 124	RS1075
REGISTER SPRING-20 x 35 Unplated length 120	RS2035



CABEL TIES – BLACK

CABLE TIE BLK (100PK)-200mm x 4.8mm	CT200
CABLE TIE BLK (100PK)-300mm x 4.8mm	CT300
CABLE TIE BLK (100PK)-370mm x 4.8mm	CT370



PANDUIT STRAPS – HEAVT DUTY

CABLE TIE HD 9MM-1220 x 9.0 (up to 350dia.)	CTHD12
CABLE TIE HD 9MM-1550 x 9.0 (up to 450dia.)	CTHD15
CABLE TIE HD 9MM-830 x 9.0 (up to 250dia.)	CTHD90



CABLE TIE TENSIONING TOOL

CABLE TIE TENSIONER TOOL HD 9MM **CTTHD**



HOOP IRON BUILDERS STRAP

HOOP IRON BUILDERS STRAP 25MM X 30MT **HI25**



AQUATITES

AQUATITE EPDM BLACK-#0 3-20mm	AQUA0
AQUATITE EPDM BLACK-#1 5-45mm	AQUA1
AQUATITE EPDM BLACK-#2 25-70mm	AQUA2
AQUATITE EPDM BLACK-#3 50-100mm	AQUA3
AQUATITE EPDM BLACK-#4 90-150mm	AQUA4
AQUATITE EPDM BLACK-#5 125-200mm	AQUA5
AQUATITE EPDM BLACK-#6 150-230mm	AQUA6
AQUATITE EPDM BLACK-#8 230-380mm	AQUA8
RETRO FIT AQUATITE SIZE: #1 8-40MM	PRAQ



WALL FLASHER

AQUATITE WALL #3 0-125MM **ATWF3**
 AQUATITE RETROFIT CLIP SS **ATSSRC**



AQUATITE ENVIRO-LEAD

AQUATITE ENVIRO-LEAD #3 Black 100-150mm **ATL3B**



DEKS TOP HAT ROOF KIT

DEKS TOP HAT ROOF KIT 65mm **DEKS065**
 DEKS TOP HAT ROOF KIT 110mm **DEKS110**



MALTHOID

MALTHOID 150 X 20MTS **MALD150**



ELEMENT WASHER M10

RUBBER WASHER M10 **ERWM10**



RUBBER WASHER 30KG

RUBBER ELEMENT 30KG **RW30**



SPLIT RUBBER WASHER - M10

SPLIT RUBBER WASHER M10 **SRWM10**



WAFFLE PAD – 10MM & 20MM (SUPER WAFFLE)

WAFFLE PAD 450 X 450MM X 10MM **WP10**
SUPER WAFFLE PAD 450 X 450 X 20MM **SWP20**



EZI CUT WAFFLE PAD – 450MM X 450MM X 10MM

EZI CUT WAFFLE PAD 10MM **EWP10**

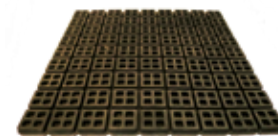

WAFFLE PAD STRIP – 1000MM X 100MM X 10MM

WAFFLE PAD 1000 X 100MM X 10MM STRIP **WPSTRIP**



MULTI LAYER PAD – 100MM X 100MM X 32MM

MULTI LAYER PADS 100X100X32 **AV101032**



HANGER BOX RUBBER ELEMENT

HANGER BOX RUBBER ELEMENT **HBRE30**



MINI SPRING KIT

MINI SPRING KIT **MS30**



MINI SPRING HANGER BOX

MINI SPRING HANGER BOX **MSHB30**



SPRING MOUNT KITS

SPRING MOUNT-30kg **SM30**

SPRING MOUNT-50kg **SM50**

SPRING MOUNT-70kg **SM70**



HANGER BOX – GALVANISED

SPRING HANGER BOX HD **SHBHD**



RUBBER FLOOR MOUNT

RUBBER FLOOR MOUNT-30kg **RFM30**

RUBBER FLOOR MOUNT-50kg **RFM50**



RUBBER MOUNTING FEET

RUBBER MOUNT (SET 4)-50mm **RM050**

RUBBER MOUNT (SET 4)-75mm **RM075**



PLASTIC STUD GROMMETS – 32MM

PLASTIC STUD GROMMETS 32MM X QTY 100 **PSG32**



METAL STUD PUNCH KIT

METAL STUD PUNCH KIT **MSPKIT**



JOINT BACKING FOAM ROD

BACKER ROD **JBFR13**



GAS & PA SYSTEMS



ALPHA  **SUPPLY**

IN STOCK | ON SITE | ON TIME

ORDERING OF HVAC MATERIALS MADE EASY

Alpha Supply Pty. Ltd.
51 Assembly Dr, Tullamarine VIC 3043
PO Box 132 Tullamarine VIC 3043
P: +61 (0) 3 9445 0848
F: +61 (0) 3 9445 0849
W: www.alphasupply.com.au
E: sales@alphasupply.com.au

GT-5 GAS TOOL

C5-ST SHORT TRAK-IT GAS TOOL **GT-5ST**



FUEL CELL

TRAK-IT® C3 FUEL CELL (BLUE) **FUELGT3**
 TRAK-IT® C5 FUEL CELL (BLACK) **FUELGT5**



TRAK-IT® C5 PINS & FUEL CELL

2.6MM X 20MM STRAIGHT SHANK PINS & FUEL CELL **GT520**



TRAK-IT® C5 PINS & FUEL CELL

22MM HARD CONCRETE PINS & FUEL CELL **GT5HC22**



GT EXTENSION POLE (6 FOOT)

6' POLE TOOL KIT (INCLUDES HANDLE, HEAD AND 280MM, 580MM & 690MM POLE EXTENSIONS) **GT-POLE4**
 EXTENSION POLE (280MM) **GT-POLE1**
 EXTENSION POLE (580MM) **GT-POLE2**
 EXTENSION POLE (690MM) **GT-POLE3**



CONTRACTORS PACK OPTION 1

CONTRACTORS PACK OPTION 1 - GTHC22 X 1000 PINS & GAS / GT3CTM X 1000 MOUNTS / GTCT200 X 1000 TIES **GT3-CTP1**



APOLO GTMAC METAL ANGLE

FIRE RATED - METAL ANGLE CLIP FOR GT-6 TOOLS **GTMAC-FR**



DOUBLE SHOT ROD HANGER

TRAKIT DOUBLE SHOT ROD HANGER **DSRH**



APOLO CABLE TIE MOUNT

DELUXE CABLE TIE MOUNT SUITS GT3 GAS TOOL (9TBB) **GT3CTM**
DELUXE CABLE TIE MOUNT **GT5CTM**



APOLO CONDUIT SADDLE

16MM PVC SINGLE CONDUIT SADDLE (FP16)	GTPVC16
20MM PVC SINGLE CONDUIT SADDLE (FP20)	GTPVC20
25MM PVC SINGLE CONDUIT SADDLE (FP25)	GTPVC25
25MM METAL SINGLE CONDUIT SADDLE (FT-25) - FIRE RATED	GTMT25



APOLO QUICK CLIP SELF LOCKING POLYAMIDE PIPE CLAMP

14 TO 18MM QUICK CLIP POLYAMIDE SELF LOCKING PIPE CLIPS (ABT18)	GTQC14-18
20 TO 25MM QUICK CLIP POLYAMIDE SELF LOCKING PIPE CLIPS (ABT25)	GTQC20-25
26 TO 32MM QUICK CLIP POLYAMIDE SELF LOCKING PIPE CLIPS (ABT32)	GTQC26-32
35 TO 42MM QUICK CLIP POLYAMIDE SELF LOCKING PIPE CLIPS (ABT42)	GTQC35-42



APOLO CHANNEL STRUT FOR QUICK CLIP SYSTEM

PVC CHANNEL STRUT FOR QUICK CLIP SYSTEM (P1000PVC)	CSPVC
METAL CHANNEL STRUT FOR QUICK CLIP SYSTEM (2000PG)	CSM



PX9C - Collated Drive Pin - 9mm Head

Powder Actuated Tool	PX375
Cleaning Kit for PX375	PX350



PXC - Collated Drive Pin - 8mm Head

16MM COLLATED 10 STRIP DRIVE PIN	PXC16M
19MM COLLATED 10 STRIP DRIVE PIN	PXC19M
27MM COLLATED 10 STRIP DRIVE PIN	PXC27M
32MM COLLATED 10 STRIP DRIVE PIN	PXC32M
37MM COLLATED 10 STRIP DRIVE PIN	PXC37M
42MM COLLATED 10 STRIP DRIVE PIN	PXC42M
52MM COLLATED 10 STRIP DRIVE PIN	PXC52M
62MM COLLATED 10 STRIP DRIVE PIN	PXC62M
72MM COLLATED 10 STRIP DRIVE PIN	PXC72M*



For use with ICCONS™ PX60M (Magazine)

Suits most brands with magazine attachment

PX9C - Collated Drive Pin - 9mm Head

20mm Collated 10 strip Drive Pin with Rubber Spring	PX9C20MRS
50mm Collated 10 strip Drive Pin with Rubber Spring	PX9C50MRS
60mm Collated 10 strip Drive Pin with Rubber Spring	PX9C60MRS
75mm Collated 10 strip Drive Pin with Rubber Spring	PX9C75MRS



PXLS - LOAD SAFETY STRIP - .27 CALIBER

.27 CALIBER 10 LOAD SAFETY STRIP (GREEN)	PXLSG (3LVS27)
.27 CALIBER 10 LOAD SAFETY STRIP (YELLOW)	PXLSY (4LVS27)
.27 CALIBER 10 LOAD SAFETY STRIP (RED)	PXLSR (5LVS27)



PXLD - LOAD DISK - .25 CALIBER

.25 CALIBER 10 LOAD DISK (YELLOW)	PXLDY (4060)
.25 CALIBER 10 LOAD DISK (RED)	PXLDR (5060)



PSV - LOAD SINGLE - .22 CALIBER

GREEN .22 CALIBER STANDARD VELOCITY CARTRIDGE	PSVG
YELLOW .22 CALIBER STANDARD VELOCITY CARTRIDGE	PSVY
RED .22 CALIBER STANDARD VELOCITY CARTRIDGE	PSVR
PURPLE .22 CALIBER STANDARD VELOCITY CARTRIDGE	PSVP



PXS - Drive Pin - 8mm Head

16mm Drive Pin	PXS16
19mm Drive Pin	PXS19
25mm Drive Pin	PXS25
32mm Drive Pin	PXS32
38mm Drive Pin	PXS38
45mm Drive Pin	PXS45
50mm Drive Pin	PXS50
57mm Drive Pin	PXS57
60mm Drive Pin	PXS60
65mm Drive Pin	PXS65
70mm Drive Pin	PXS70
75mm Drive Pin	PXS75
100mm Drive Pin	PXS99*



MICKEY PINS

20 X 2.5MM WASHERED MICKEY PIN HAND DRIVE NAIL	MPW20
25 X 2.5MM WASHERED MICKEY PIN HAND DRIVE NAIL	MPW25
30 X 2.5MM WASHERED MICKEY PIN HAND DRIVE NAIL	MPW30
40 X 2.5MM WASHERED MICKEY PIN HAND DRIVE NAIL	MPW40
50 X 2.5MM WASHERED MICKEY PIN HAND DRIVE NAIL	MPW50



PXSC - BALLISTIC POINT - 8MM HEAD

50MM BALLISTIC POINT DRIVE PIN	PXSC50
60MM BALLISTIC POINT DRIVE PIN	PXSC60
75MM BALLISTIC POINT DRIVE PIN	PXSC75



PHV DRIVE PIN - 6MM HEAD

50MM X 6MM HEAD	PHV50
65MM X 6MM HEAD	PHV65
75MM X 6MM HEAD	PHV75
90MM X 6MM HEAD	PHV90



PXTH - TOP HAT ASSEMBLY

16MM DRIVE PIN WITH TOP HAT ASSEMBLY	PXTH16
19MM DRIVE PIN WITH TOP HAT ASSEMBLY	PXTH19
25MM DRIVE PIN WITH TOP HAT ASSEMBLY	PXTH25



PXW - METAL WASHER ASSEMBLY

25MM DRIVE PIN WASHERED	PXW25
32MM DRIVE PIN WASHERED	PXW32
38MM DRIVE PIN WASHERED	PXW38



PXWTH - METAL WASHER WITH TOP HAT

20MM DRIVE PIN WASHERED WITH TOP HAT ASSEMBLY	PXWTH20
25MM DRIVE PIN WASHERED WITH TOP HAT ASSEMBLY	PXWTH25
30MM DRIVE PIN WASHERED WITH TOP HAT ASSEMBLY	PXWTH30



PXIW - METAL INSULATION WASHER

38MM DRIVE PIN WITH INSULATION WASHER	PXIW38
65MM DRIVE PIN WITH INSULATION WASHER	PXIW65



PXIF - INSULATION FASTENERS

INSULATION FASTENER WITH 37MM DRIVE PIN FOR 25MM INSULATION	PXIF025
INSULATION FASTENER WITH 42MM DRIVE PIN FOR 30MM INSULATION	PXIF030
INSULATION FASTENER WITH 42MM DRIVE PIN FOR 35MM INSULATION	PXIF035
INSULATION FASTENER WITH 52MM DRIVE PIN FOR 40MM INSULATION	PXIF040
INSULATION FASTENER WITH 52MM DRIVE PIN FOR 50MM INSULATION	PXIF050
INSULATION FASTENER WITH 52MM DRIVE PIN FOR 75MM INSULATION	PXIF075
INSULATION FASTENER WITH 52MM DRIVE PIN FOR 100MM INSULATION	PXIF100



PXCC - ANGLE CLIP

PX - DRIVE PIN 27MM WITH ANGLE CLIP	PXCC27
25MM DRIVE PIN WITH ANGLE CLIP	PXCC25
32MM DRIVE PIN WITH ANGLE CLIP	PXCC32
25MM DRIVE PIN WASHERED - ANGLE CLIP WITH TOP HAT	PXCCT25



PXCCSC - ANGLE CLIP - BALLISTIC POINT

PX - DRIVE PIN 32MM BALLISTIC WITH ANGLE CLIP	PXCCSC32
---	----------



PXTR - M10 THREADED ROD HANGER

M10 ROD HANGER ASSEMBLY WITH 27MM TWIST SHANK DRIVE PIN	PXTRM10
---	---------



PXCON - CONDUIT CLIP - METAL

25MM CONDUIT CLIP - METAL WITH 25MM DRIVE PIN	PXCON25
---	---------



PXCT - CABLE TIE ASSEMBLY

240MM CABLE TIE WITH 32MM DRIVE PIN	PXCT240
-------------------------------------	---------



KNURLED SHANK MASONRY NAIL

3.7X25MM	KMN25
3.7X40MM	KMN40
3.7X50MM	KMN50
3.7X65MM	KMN65
3.7X75MM	KMN75



QUICKZIP WIRE SUSPENSION SYSTEM

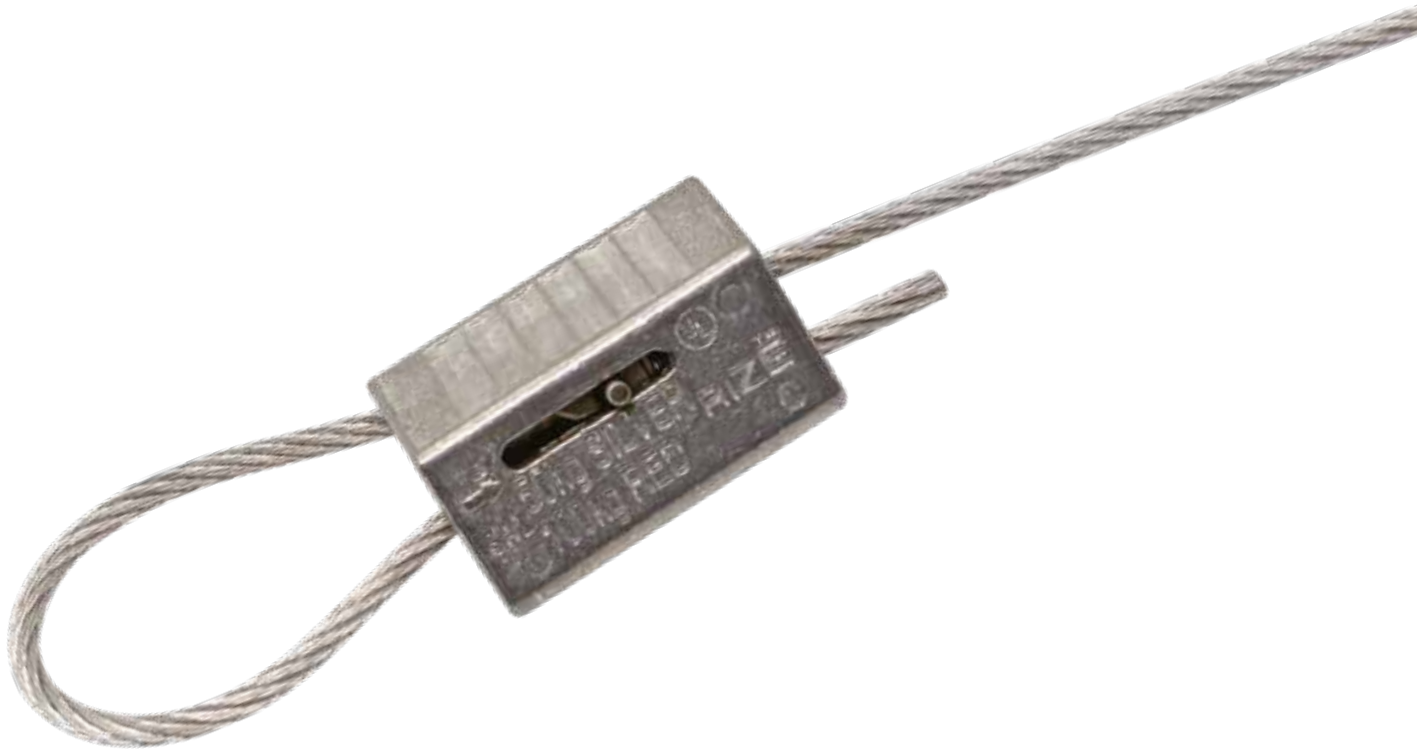

ALPHA  **SUPPLY**

IN STOCK | ON SITE | ON TIME

ORDERING OF HVAC MATERIALS MADE EASY

Alpha Supply Pty. Ltd.
51 Assembly Dr, Tullamarine VIC 3043
PO Box 132 Tullamarine VIC 3043
P: +61 (0) 3 9445 0848
F: +61 (0) 3 9445 0849
W: www.alphasupply.com.au
E: sales@alphasupply.com.au

QUICKZIP CLUTCHES

ZIP CLIP KL100 – 50KG	KL100
ZIP CLIP KL150 – 100KG	KL150



QUICKZIP DUCT BRACKET WITH CLUTCH

KV12 DUCT BRACKET	KV12
-------------------	------



Ideal to screw to ductwork utilising an internally mounted Quickzip Clutch.

QUICKZIP WIRE

WIRE ROPE 7X7 GAL PER METRE 2MM	WR100
---------------------------------	-------



QUICKZIP WIRE ROPE CUTTER

TOLEDO WIRE ROPE AND SPRING CUTTER	WRSC
------------------------------------	------



QUICKZIP WITH 2MM LOOPEND

QUICKZIP 2MM LOOPEND 1M	KL2LED1
QUICKZIP 2MM LOOPEND 2M	KL2LED2
QUICKZIP 2MM LOOPEND 3M	KL2LED3
QUICKZIP 2MM LOOPEND 4M	KL2LED4
QUICKZIP 2MM LOOPEND 5M	KL2LED5



Ideal for looping around structurally sound roof trusses, beams or purlins

Custom lengths available on request

QUICKZIP WITH 2MM CEILING CLIP

QUICKZIP 2MM CEILING CLIP 1M	KL2CCP1
QUICKZIP 2MM CEILING CLIP 2M	KL2CCP2
QUICKZIP 2MM CEILING CLIP 3M	KL2CCP3
QUICKZIP 2MM CEILING CLIP 4M	KL2CCP4
QUICKZIP 2MM CEILING CLIP 5M	KL2CCP5



Ideal for hanging from purlins directly

Custom lengths available on request

QUICKZIP WITH 2MM POSTHEAD

QUICKZIP 2MM M10 POSTHEAD 1M	KL2PHD1
QUICKZIP 2MM M10 POSTHEAD 2M	KL2PHD2
QUICKZIP 2MM M10 POSTHEAD 3M	KL2PHD3
QUICKZIP 2MM M10 POSTHEAD 4M	KL2PHD4
QUICKZIP 2MM M10 POSTHEAD 5M	KL2PHD5



Ideal to fix the M10 posthead to existing or newly installed M10 threaded rod

Custom lengths available on request

QUICKZIP 2MM WITH STUD END

QUICKZIP 2MM STUD END 1M	KL2SED1
QUICKZIP 2MM STUD END 2M	KL2SED2
QUICKZIP 2MM STUD END 3M	KL2SED3
QUICKZIP 2MM STUD END 4M	KL2SED4
QUICKZIP 2MM STUD END 5M	KL2SED5



Ideal to screw directly into an M10 drop in anchor (bulldog)

Custom lengths available on request

QUICKZIP 2MM WITH STRIKE ANCHOR 5MM & 6MM

QUICKZIP 2MM STRIKE ANCHOR 5MM 1M	KL2SA51
QUICKZIP 2MM STRIKE ANCHOR 5MM 2M	KL2SA52
QUICKZIP 2MM STRIKE ANCHOR 5MM 3M	KL2SA53
QUICKZIP 2MM STRIKE ANCHOR 5MM 4M	KL2SA54
QUICKZIP 2MM STRIKE ANCHOR 5MM 5M	KL2SA55
QUICKZIP 2MM STRIKE ANCHOR 6.5MM 1M	KL2SA61
QUICKZIP 2MM STRIKE ANCHOR 6.5MM 2M	KL2SA62
QUICKZIP 2MM STRIKE ANCHOR 6.5MM 3M	KL2SA63
QUICKZIP 2MM STRIKE ANCHOR 6.5MM 4M	KL2SA64
QUICKZIP 2MM STRIKE ANCHOR 6.5MM 5M	KL2SA65



Ideal for fixing directly into concrete structures

Custom lengths available on request

QUICKZIP 2MM WITH ANGLE CLIP 27MM

QUICKZIP 2MM PX DRIVE PIN 27MM ANGLE CLIP 1M	KL2PX271
QUICKZIP 2MM PX DRIVE PIN 27MM ANGLE CLIP 2M	KL2PX272
QUICKZIP 2MM PX DRIVE PIN 27MM ANGLE CLIP 3M	KL2PX273
QUICKZIP 2MM PX DRIVE PIN 27MM ANGLE CLIP 4M	KL2PX274
QUICKZIP 2MM PX DRIVE PIN 27MM ANGLE CLIP 5M	KL2PX275



Ideal for fixing into concrete structures using a P.A gun

Custom lengths available on request

QUICKZIP 2MM WITH ANGLE CLIP 25MM

QUICKZIP 2MM PX DRIVE PIN 25MMWITH ANGLE CLIP 1M	KL2PX251
QUICKZIP 2MM PX DRIVE PIN 25MMWITH ANGLE CLIP 2M	KL2PX252
QUICKZIP 2MM PX DRIVE PIN 25MMWITH ANGLE CLIP 3M	KL2PX253
QUICKZIP 2MM PX DRIVE PIN 25MMWITH ANGLE CLIP 4M	KL2PX254
QUICKZIP 2MM PX DRIVE PIN 25MMWITH ANGLE CLIP 5M	KL2PX255



Ideal for fixing into concrete structures using a P.A gun

Custom lengths available on request

CABLE TRAY

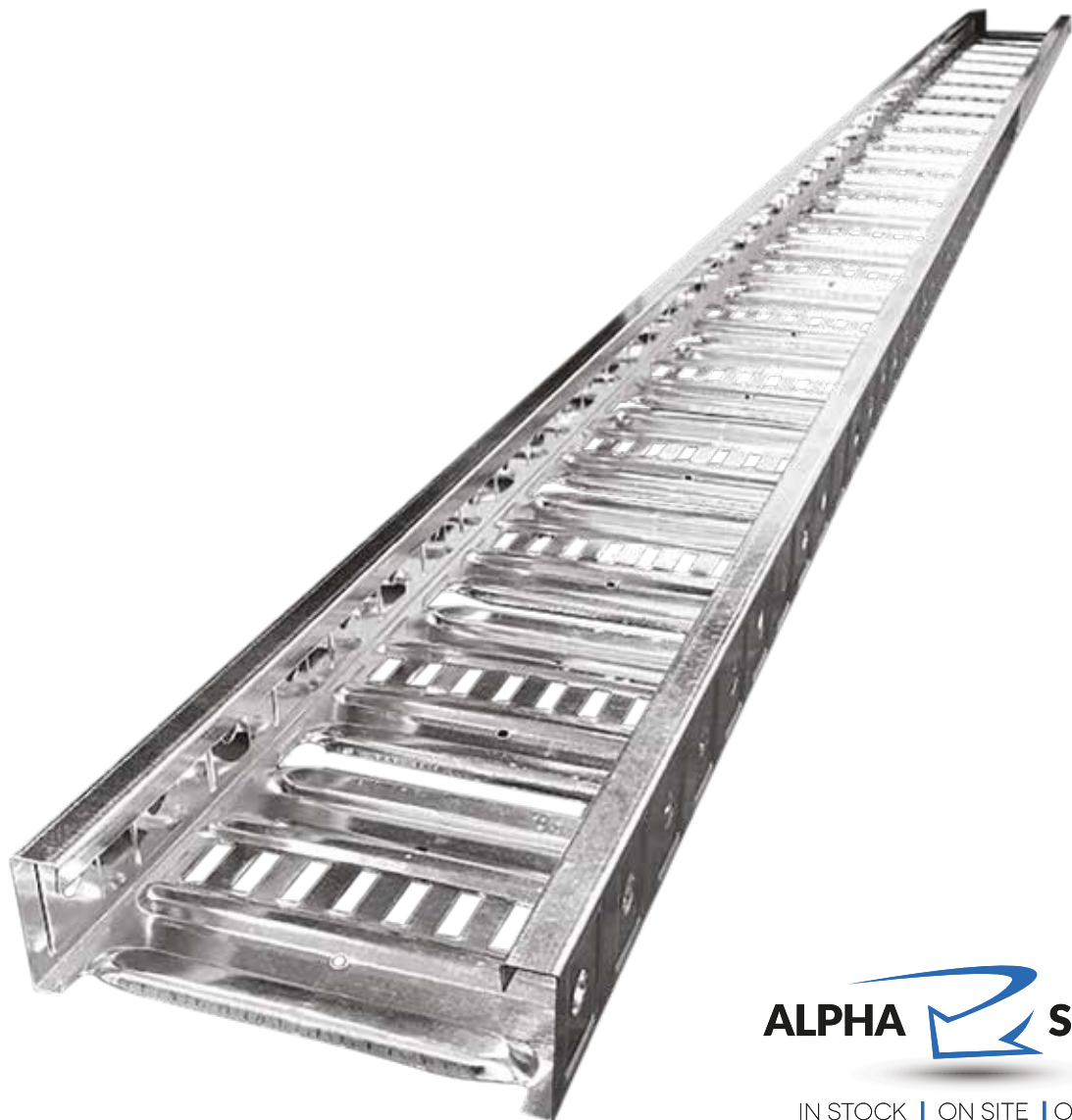

ALPHA  **SUPPLY**

IN STOCK | ON SITE | ON TIME

ORDERING OF HVAC MATERIALS MADE EASY

Alpha Supply Pty. Ltd.
51 Assembly Dr, Tullamarine VIC 3043
PO Box 132 Tullamarine VIC 3043
P: +61 (0) 3 9445 0848
F: +61 (0) 3 9445 0849
W: www.alphasupply.com.au
E: sales@alphasupply.com.au

T3 CABLE TRAY

LADDER TRAY T3 GB 3M 150MM	T3LT150
LADDER TRAY T3 GB 3M 300MM	T3LT300
LADDER TRAY T3 GB 3M 450MM	T3LT450
LADDER TRAY T3 GB 3M 600MM	T3LT600



T3 CABLE TRAY COVER

T3 FLAT COVER GB 3M 150MM	T3FC150
T3 FLAT COVER GB 3M 300MM	T3FC300
T3 FLAT COVER GB 3M 450MM	T3FC450



T3 CABLE TRAY SPLICE PLATE

T3 SPLICE PLATE GB	T3SP
--------------------	------



T3 BOLTS AND NUTS

T3 BOLT ZP M10	T3BOLT
T3 NUT ZP M10	T3NUT



T3 CABLE TRAY RADIUS PLATE

T3 LADDER TRAY RADIUS PLATE GB 3M	T3RPL
-----------------------------------	-------



T3 CABLE TRAY TX BRACKET

T3 TX BRACKET	T3TX
---------------	------



T3 CABLE TRAY TRAPEZE SUPPORT

TRAPEZE SUPPORT GB150MM	T3TS150
TRAPEZE SUPPORT GB300MM	T3TS300
TRAPEZE SUPPORT GB 450MM	T3TS450



FRAMO 80



ALPHA  **SUPPLY**

IN STOCK | ON SITE | ON TIME

ORDERING OF HVAC MATERIALS MADE EASY

Alpha Supply Pty. Ltd.
51 Assembly Dr, Tullamarine VIC 3043
PO Box 132 Tullamarine VIC 3043
P: +61 (0) 3 9445 0848
F: +61 (0) 3 9445 0849
W: www.alphasupply.com.au
E: sales@alphasupply.com.au

FRAMO 80 BEAM SECTION

FRAMO 80 BEAM SECTION **F80BS**



FRAMO 80 END CAP

FRAMO 80 END CAP **F80EC**



FRAMO 80 HEX SELF FORMING SCREW

FRAMO 80 HEX SELF FORMING SCREW **F80HS**



FRAMO 80 END SUPPORT – CENTRE

FRAMO 80 END SUPPORT – CENTRE **F80ESC**



FRAMO 80 END SUPPORT – OFF CENTRE

FRAMO 80 END SUPPORT – OFF CENTRE **F80ESO**



FRAMO 80 END SUPPORT BASE PLATE

FRAMO 80 END SUPPORT **F80BP**



FRAMO 80 STRUT ADAPTOR

FRAMO 80 STRUT ADAPTOR **F80SA**



FRAMO 80 – BEAM SECTION HOLDER

FRAMO 80 BEAM SECTION HOLDER **F80SH**



SEALANTS AND ADHESIVES



ALPHA  **SUPPLY**

IN STOCK | ON SITE | ON TIME

ORDERING OF HVAC MATERIALS MADE EASY

Alpha Supply Pty. Ltd.
51 Assembly Dr, Tullamarine VIC 3043
PO Box 132 Tullamarine VIC 3043
P: +61 (0) 3 9445 0848
F: +61 (0) 3 9445 0849
W: www.alphasupply.com.au
E: sales@alphasupply.com.au

DUCT TAPE

NITTO DUCT TAPE 48MMX30M BLACK	DTBLACK
NITTO DUCT TAPE 48MMX30M GREY	DTGREY
NITTO DUCT TAPE 48MMX30M WHITE	DTWHITE



HANGING STRAP

BLUE HANGING STRAP 25MMX50M	HANGB
-----------------------------	-------



DUCT SADDLE BRACE

DUCT BRACE	BRADH
------------	-------



DUCT SADDLE BRACE – ADHESIVE BACK

DUCT BRACE ADHESIVE	DSBER
---------------------	-------

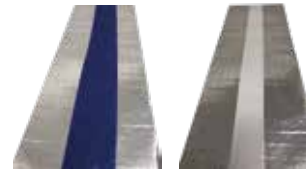

DUCT SADDLE BRACE – PERFERATED

DUCT SADDLE BRACE PERF	SBP75
------------------------	-------

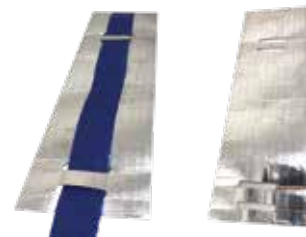

ALUMINIUM REINFORCED FOIL TAPE

ALUM FOIL TAPE REINFORCED 48MM	AFTR048
ALUM FOIL TAPE REINFORCED 72MM	AFTR072



ALUMINIUM FOIL TAPE

ALUM FOIL TAPE 48MM	AFT048
ALUM FOIL TAPE 72MM	AFT072



FOAM TAPE

FOAM TAPE 15M ROLL-5MM X 12MM	FT512
FOAM TAPE 15M ROLL-5MM X 18MM	FT518



ELECTRICAL TAPE

ELECTRICAL TAPE 19MM X 20M BLACK	ETBLA
ELECTRICAL TAPE 19MM X 20M BLUE	ETBLU
ELECTRICAL TAPE 19MM X 20M EARTH	ETEAR
ELECTRICAL TAPE 19MM X 20M RED	ETRED
ELECTRICAL TAPE 19MM X 20M WHITE	ETWHT



DUCT PROTECTION FILM

HVAC PROTECTION FILM BLUE 1220mmx60mx50um	FILM1220
---	----------



PVC CEMENT

SOLVENT CEMENT 500ML BLUE	SC500B
SOLVENT CEMENT 500ML CLEAR	SC500C
SOLVENT CEMENT 500ML GREEN	SC500G



PRIMING FLUID

PRIMING FLUID 500ML CLEAR	PF500C
PRIMING FLUID 500ML RED	PF500R



DUCT SEALANT

FOSTERS DUCT SEALANT WB 420G	DSWB
DUCT SEALANT - 4L	DSWB4L



SILICONE

SILICONE CARTRIDGE TRANS	SCHBT
SILICONE CARTRIDGE GREY	SCHBG
SILICONE CARTRIDGE ALUMINIUM	SCHBA
SILICONE CARTRIDGE BLACK	SCHBB
SILICONE CARTRIDGE WHITE	SCHBW

Fulaseal 780 Plumbers Silicone is a neutral cure sealant which does not corrode materials commonly use in roof and gutters. Used in sheet metal and aluminium roofing application, exterior cladding, guttering, flashing and downpipes.



FIRESOUND FIRE RATED SILICONE

FIRESOUND GREY SEALANT 450G CARTRIDGE **FSGC**

FIRESOUND GREY SEALANT 600ML SAUSAGE **FSGS**

Firesound is a one part, water based construction sealant for sealing joints and penetrations where fire resistance is required, or where an acoustic rated sealant is required.



FIRE MASTIC – BOSS HPE

FIRE MASTIC HPE 300ML CARTRIDGE **FMHPE**

FireMastic-HPE is a new High Pressure Exerting fire sealant to surpass all other sealants. The sealant is tested and approved to change the way firestopping is applied to pipes and penetrations.



HI TEMP SILICONE

HI TEMP SILICONE HBF260 300G **HBF260R**

FulasealPRO 260 Hi Temp Silicone is a multipurpose one component RTV silicone used for industrial sealing and bonding where temperature resistance is required. It forms a tough rubber like film which outperforms standard grade silicones.



FIRE RESISTANT EXPANDING FOAM

FIRE RESISTANT EXPANDING FOAM 500ML **FREXP500**



TOOLBOX ADHESIVE

TOOLBOX ADHESIVE 400G GREY **TBOXCG**

Toolbox™ is a hybrid moisture curing adhesive and sealant with high grab strength for use in a wide variety of critical adhesive and sealing applications. Toolbox™ cures to form a tough, waterproof seal and will adhere to a wide range of substrates. Its versatility means it can replace most water based and solvent based construction adhesives, polyurethane adhesive and sealants as well as silicones in construction, marine, transport and industrial assembly applications.



SUPERSEAL HPR RANGE

SUPERSEAL HPR 25 CARTRIDGE	BLACK	HPR25B
SUPERSEAL HPR 25 CARTRIDGE	GREY	HPR25G
SUPERSEAL HPR 25 CARTRIDGE	WHITE	HPR25W

Superseal HPR 25 is a high performance, one part hybrid moisture curing construction sealant, which cures to form a seal that is tough, elastic and weatherproof. Superseal HPR Construction MS is a low modulus product for use in situations that may experience significant expansion and contraction. Superseal HPR 25 is easy to apply and tool off. Fast skinning allows for rapid job turnaround.



CONSTRUCTION ADHESIVE

CONSTRUCTION ADHESIVE 320G **CONAD**

Fuller Trade construction adhesive is ideal for bonding timber and most common construction materials including particle board, MDF board, brick, concrete, gypsum board, galvanized metal and aluminum. Fuller Trade construction adhesive is a synthetic rubber based adhesive designed primarily for installation of flooring and wall panels. Fuller Trade construction adhesive can be used in many general household applications.



CONSTRUCTION ACRYLIC GAPE FILLER – WHITE

ACRYLIC GAP FILLER WHITE 450G AGFWHT

Fuller Trade Gap Filler is a premium quality general purpose acrylic based gap filler.



COOLROOM MASTIC

FULASEAL PRO COOLROOM MASTIK 420GM CRM420

FulasealPRO 840NS is a butyl-based nonsagging, non-skinning gunnable small joint sealant that provides excellent moisture resistance. It has been designed for use in cool room construction, refrigerated container components and other types of insulation panels. It is suitable for applications requiring a non-skinning, durable and permanently plastic sealant.



FOOD GRADE SILICONE

FULLASEAL PRO 730 FOOD GRADE SILICONE FGS730

FulaSealPRO 730™ Industrial Grade Silicone forms a tough rubber like film which out-performs standard grade silicones and is UV, vibration and temperature resistant.



CHEMSET

CHEMSELECT POLYESTER STYRENE FREE 300ML M50E

Styrene free, medium duty, two part polyester injection system for anchoring threaded rod and rebar



MARKING PAINT

MARKING PAINT FLUORO 350G-Blue	MPBLUE
MARKING PAINT FLUORO 350G-Green	MPGREEN
MARKING PAINT FLUORO 350G-Orange	MPORANGE
MARKING PAINT FLUORO 350G-Pink	MPPINK
MARKING PAINT FLUORO 350G-Red	MPRED
MARKING PAINT FLUORO 350G-Yellow	MPYELLOW



SPRAY PAINT

SPRAY PAINT 250G-Matt Black	SPMB
SPRAY PAINT 250G-Gloss Black	SPGB
SPRAY PAINT 250G-Gloss White	SPGW



COLD GALVANISING SPRAY

COLD GAL SPRAY 350G	CGS
---------------------	-----



Protective barrier against corrosion

CLEANING ABRASIVE

RED BACK CLEANING ABRASIVE	RBCA
----------------------------	------



Waterproof

Silicone carbide abrasive strips

Replaces steel wool or emery paper

FIT OFF TAPE

RED BACK FIT OFF TAPE	RBFOT
-----------------------	-------



Approved thread tape for water, air and gas

PIPE INSULATION ADHESIVE

INSULATION ADHESIVE	PIA
---------------------	-----



Quick drying adhesive

High resistance to water vapour

VENTILATION



ALPHA  **SUPPLY**

IN STOCK | ON SITE | ON TIME

ORDERING OF HVAC MATERIALS MADE EASY

Alpha Supply Pty. Ltd.
51 Assembly Dr, Tullamarine VIC 3043
PO Box 132 Tullamarine VIC 3043
P: +61 (0) 3 9445 0848
F: +61 (0) 3 9445 0849
W: www.alphasupply.com.au
E: sales@alphasupply.com.au

R1 SILVER 3 ZERO FLEXIBLE DUCT – 6 METER

R1 SILVER 3ZERO DUCT 6M-150mm (6")	R13Z06
R1 SILVER 3ZERO DUCT 6M-200mm (8")	R13Z08
R1 SILVER 3ZERO DUCT 6M-250mm (10")	R13Z10
R1 SILVER 3ZERO DUCT 6M-300mm (12")	R13Z12
R1 SILVER 3ZERO DUCT 6M-350mm (14")	R13Z14
R1 SILVER 3ZERO DUCT 6M-400mm (16")	R13Z16
R1 SILVER 3ZERO DUCT 6M-450mm (18")	R13Z18
R1 SILVER 3ZERO DUCT 6M-500mm (20")	R13Z20
R1 SILVER 3ZERO DUCT 6M-550mm (22")	R13Z22



R1.5 SILVER 3 ZERO DUCT – 6 METER

R1.5 SILVER 3 ZERO DUCT 6M-150mm (6")	R153Z06
R1.5 SILVER 3 ZERO DUCT 6M-200mm (8")	R153Z08
R1.5 SILVER 3 ZERO DUCT 6M-250mm (10")	R153Z10
R1.5 SILVER 3 ZERO DUCT 6M-300mm (12")	R153Z12
R1.5 SILVER 3 ZERO DUCT 6M-350mm (14")	R153Z14
R1.5 SILVER 3 ZERO DUCT 6M-400mm (16")	R153Z16
R1.5 SILVER 3 ZERO DUCT 6M-450mm (18")	R153Z18
R1.5 SILVER 3 ZERO DUCT 6M-500mm (20")	R153Z20
R1 SILVER 3ZERO DUCT 6M-550mm (22")	R13Z22



R2 SILVER 3 ZERO DUCT – 6 METER

R2 SILVER 3 ZERO DUCT 6M-150mm (6")	R23Z06
R2 SILVER 3 ZERO DUCT 6M-200mm (8")	R23Z08
R2 SILVER 3 ZERO DUCT 6M-250mm (10")	R23Z10
R2 SILVER 3 ZERO DUCT 6M-300mm (12")	R23Z12
R2 SILVER 3 ZERO DUCT 6M-350mm (14")	R23Z14
R2 SILVER 3 ZERO DUCT 6M-400mm (16")	R23Z16
R2 SILVER 3 ZERO DUCT 6M-450mm (18")	R23Z18
R2 SILVER 3 ZERO DUCT 6M-500mm (20")	R23Z20
R1 SILVER 3ZERO DUCT 6M-550mm (22")	R13Z22



ACCOUSTIC R1 SILVER 3 ZERO DUCT – 6 METER

R1 SILVER 3ZERO ACC DUCT 6M-150mm (6")	3ZR1AC06
R1 SILVER 3ZERO ACC DUCT 6M-200mm (8")	3ZR1AC08
R1 SILVER 3ZERO ACC DUCT 6M-250mm (10")	3ZR1AC10
R1 SILVER 3ZERO ACC DUCT 6M-300mm (12")	3ZR1AC12
R1 SILVER 3ZERO ACC DUCT 6M-350mm (14")	3ZR1AC14
R1 SILVER 3ZERO ACC DUCT 6M-400mm (16")	3ZR1AC16
R1 SILVER 3ZERO ACC DUCT 6M-450mm (18")	3ZR1AC18
R1 SILVER 3ZERO ACC DUCT 6M-500mm (20")	3ZR1AC20



3 ZERO NUDE CORE FLEX

NUDE CORE FLEX 3 ZERO-100mm (4")	NC3Z04
NUDE CORE FLEX 3 ZERO-125mm (5")	NC3Z05
NUDE CORE FLEX 3 ZERO-150mm (6")	NC3Z06
NUDE CORE FLEX 3 ZERO-200mm (8")	NC3Z08
NUDE CORE FLEX 3 ZERO-250mm (10")	NC3Z10
NUDE CORE FLEX 3 ZERO-300mm (12")	NC3Z12
NUDE CORE FLEX 3 ZERO-350mm (14")	NC3Z14
NUDE CORE FLEX 3 ZERO-400mm (16")	NC3Z16
NUDE CORE FLEX 3 ZERO-450mm (18")	NC3Z18
NUDE CORE FLEX 3 ZERO-500mm (20")	NC3Z20



SEMI RIGID ALUMINIUM DUCT

SEMI RIGID ALU DUCT 3M-125mm - (5")	SRAD5
SEMI RIGID ALU DUCT 3M-150mm - (6")	SRAD6
SEMI RIGID ALU DUCT 3M 200MM	SRAD8



METAL DUCT JOINER

METAL JOINER 150mm (6")	MJ06
METAL JOINER 200mm (8")	MJ08
METAL JOINER 250mm (10")	MJ10
METAL JOINER 300mm (12")	MJ12
METAL JOINER 350mm (14")	MJ14
METAL JOINER 400mm (16")	MJ16
METAL JOINER 450mm (18")	MJ18
METAL JOINER 500mm (20")	MJ20



METAL STARTING COLLAR

METAL STARTING COLLAR 150MM	MSC06
METAL STARTING COLLAR 200MM	MSC08
METAL STARTING COLLAR 300MM	MSC12
METAL STARTING COLLAR 350MM	MSC14
METAL STARTING COLLAR 400MM	MSC16
METAL STARTING COLLAR 450MM	MSC18



PLAIN BRANCH TAKE OFF

BTO PLAIN 150.150.150	BTOP666
BTO PLAIN 200.150.150	BTOP866
BTO PLAIN 200.200.150	BTOP886
PLAIN 200.200.200	BTOP888



INSULATED BRANCH TAKE OFF

BTO INSULATED 200.150.150	BTOI866
BTO INSULATED 250.200.150	BTOI10.8.6
BTO INSULATED 250.200.200	BTOI1088
BTO INSULATED 300.250.250	BTOI12.10.10
BTO INSULATED 300.250.150	BTOI12106
BTO INSULATED 350.300.250	BTOI141210
BTO INSULATED 350.300.300	BTOI14.12.12



INSULATED DOUBLE BTO

DBTO INSULATED 200.150.150.150	DBTOI8666
DBTO INSULATED 250.200.150.250	DBTOI10866
DBTO INSULATED 250.200.200.200	DBTOI10888
DBTO INSULATED 300.250.250.250	DBTOI12101010
DBTO INSULATED 300.250.200.200	DBTOI121088



POLY REDUCER

Y BRANCH PLAIN150.150.150	YBP666
Y BRANCH PLAIN200.150.150	YBP866



Y BRANCH – PLAIN

POLY REDUCER 150-100mm	PR65
POLY REDUCER 200-150mm	PR68



CONE DIFFUSER – PLASTIC

CONE DIFFUSER 150mm	CD06
CONE DIFFUSER 200mm	CD08
CONE DIFFUSER 250mm	CD10
CONE DIFFUSER 300mm	CD12



EGG CRATE GRILLE – T BAR

EGG CRATE GRILLE 1/2 T-BAR 550 X 550	ECGHT
EGG CRATE GRILLE FULL T-BAR 1150 X 550	ECGFT



EGG CRATE GRILLE WITH ADAPTOR

EGG CRATE 150 X 150 - NECK 150	ECG150
EGG CRATE 200 X 200 - NECK 200	ECG200
EGG CRATE 250 X 250 - NECK 250	ECG250



ALUMINIUM LAY IN DIFFUSER – 4 WAY

595 X 595 LAY IN ALUMINIUM DIFFUSER - 4 WAY - 450 NECK **LID4W**



ALUMINIUM LAY IN DIFFUSER – SWIRL

595 X 595 LAY IN ALUMINIUM SWIRL DIFFUSER - 450 NECK **LISWL**



DOOR RELIEF GRILLE

DOOR RELIEF GRILLE 600 X 150	DG6015
DOOR RELIEF GRILLE 600 X 200	DG6020
DOOR RELIEF GRILLE 600 X 250	DG6025
DOOR RELIEF GRILLE 600 X 300	DG6030
DOOR RELIEF GRILLE 600 X 400	DG6040
DOOR RELIEF GRILLE 600 X 600	DG6045



CUSHION HEAD BOXES – T BAR

450 X 450 CUSHION HEAD BOX - 200 NECK SIZE	CHB4520
450 X 450 CUSHION HEAD BOX - 250 NECK SIZE	CHB4525
450 X 450 CUSHION HEAD BOX - 300 NECK SIZE	CHB4530
450 X 450 CUSHION HEAD BOX - 350 NECK SIZE	CHB4535
450 X 450 CUSHION HEAD BOX - 400 NECK SIZE	CHB4540



BELLMOUTH SPIGOT WITH DAMPER

150MM LONG NECK BELLMOUTH SPIGOT WITH DAMPER	BSD15
200MM LONG NECK BELLMOUTH SPIGOT WITH DAMPER	BSD20
250MM LONG NECK BELLMOUTH SPIGOT WITH DAMPER	BSD25
300MM LONG NECK BELLMOUTH SPIGOT WITH DAMPER	BSD30
350MM LONG NECK BELLMOUTH SPIGOT WITH DAMPER	BSD35
400MM LONG NECK BELLMOUTH SPIGOT WITH DAMPER	BSD40



NON RETURN DAMPER – BUTTERFLY TYPE

150mm Non Return Damper	NRD15
200mm Non Return Damper	NRD20
250mm Non Return Damper	NRD25



INLINE FAN – MIXED FLOW

150mm Mixed Flow Inline Fan	MFF15
200mm Mixed Flow Inline Fan	MFF20
250mm Mixed Flow Inline Fan	MFF25



FASTCLAMP TO SUIT INLINE FAN

FASTCLAMP TO SUIT 150MM INLINE FAN	FFC150
FASTCLAMP TO SUIT 200MM INLINE FAN	FFC200



HEADER BOX FAN

HEADER BOX FAN 150MM	HBF150
HEADER BOX FAN 150MM WITH RUN ON TIMER	HBFT150



DRIP TRAY

830 X 830 x 50 DRIP TRAY	DT1
1130 X 830 x 50 DRIP TRAY	DT2
1430 X 830 x 50 DRIP TRAY	DT3
1730 X 830 x 50 DRIP TRAY	DT4
1250 X 750 x 50 DRIP TRAY	DT5
1500 X 950 x 50 DRIP TRAY	DT6



CHINA HAT ROOF COWL

CHINA HAT COWL-150mm	RCOWL15
CHINA HAT COWL-200mm	RCOWL20



DOWNPIPE

DOWNPIPE 1.8M-150mm	DP1815
---------------------	--------



MUSHROOM COWL KIT

MUSHROOM COWL KIT 600MM 150mm	RMC6
MUSHROOM COWL KIT 600MM 200mm	RMC8



FLAT DUCT LENGTHS

FLAT DUCT 2M-220 x 90mm	FDLEN220
FLAT DUCT 2M-350 x 75mm	FDLEN350

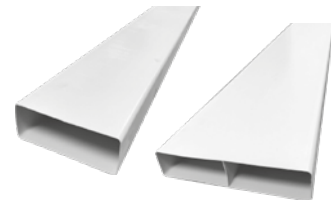

FLAT DUCT JOINER

FLAT DUCT JOINER 220 x 90mm	FDJ220
FLAT DUCT JOINER 350 x 75mm	FDJ350

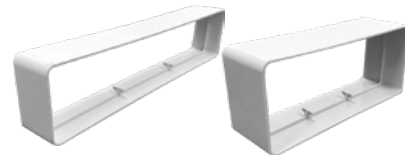

FLAT DUCT METAL SUPPORT BRACKET

FLAT DUCT METAL SUPPORT BRACKET 220X90	FDMB220
FLAT DUCT METAL SUPPORT BRACKET 350X75	FDMB350

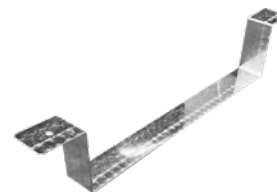

FLAT DUCT HORIZONTAL 90 DEGREE ELBOW

FLAT DUCT 90 DEG FLAT H ELBOW 220 x 90mm	FDH90220
FLAT DUCT 90 DEG FLAT H ELBOW 350 x 75mm	FDH90350

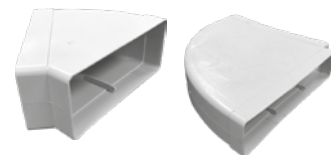

FLAT DUCT HORIZONTAL 45 DEGREE ELBOW

FLAT DUCT 45 DEG FLAT H ELBOW 220 x 90mm	FDH45220
FLAT DUCT 45 DEG FLAT H ELBOW 350 x 75mm	FDH45350



FLAT DUCT 90 DEGREE VERTICAL ELBOW

FLAT DUCT 90 DEG VERTICAL ELBOW 220 x 90mm	FDV90220
FLAT DUCT 90 DEG VERTICAL ELBOW 350 x 75mm	FDV90350

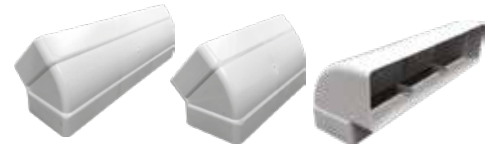

FLAT DUCT 45 DEGREE VERTICAL ELBOW

FLAT DUCT 45 DEG VERTICAL ELBOW 220 x 90mm	FDV45220
FLAT DUCT 45 DEG VERTICAL ELBOW 350 x 75mm	FDV45350



FLAT DUCT SQUARE TO ROUND ADAPTOR

FLAT DUCT ROUND TO REC 150MM 220 x 90mm	FDA6220
FLAT DUCT ROUND TO REC 150MM 350 x 75mm	FDA6350



FLAT DUCT RANGE HOOD ADAPTOR

FLAT DUCT RANGHOOD ADAPTOR 220 x 90mm	FDRH220
FLAT DUCT RANGHOOD ADAPTOR 350 x 75mm	FDRH350



FLAT DUCT TEE

FLAT DUCT TEE 220 x 90mm	FDT220
FLAT DUCT TEE 350 x 75mm	FDT350



FLAT DUCT ROUND TO ROUND ADAPTOR

FLAT DUCT ROUND TO ROUND ADAPTOR 150-125mm	FDRR65
FLAT DUCT ROUND TO ROUND ADAPTOR 200-150mm	FDRR86



FIRE PROTECTION



ALPHA  **SUPPLY**

IN STOCK | ON SITE | ON TIME

ORDERING OF HVAC MATERIALS MADE EASY

Alpha Supply Pty. Ltd.
51 Assembly Dr, Tullamarine VIC 3043
PO Box 132 Tullamarine VIC 3043
P: +61 (0) 3 9445 0848
F: +61 (0) 3 9445 0849
W: www.alphasupply.com.au
E: sales@alphasupply.com.au

MICRO RETROFIT FIRE COLLAR

RETROFIT FIRE COLLAR MICRO	20mm	RFCM20
RETROFIT FIRE COLLAR MICRO	25mm	RFCM25
RETROFIT FIRE COLLAR MICRO	32mm	RFCM32



RETROFIT FIRE COLLAR

RETROFIT FIRE COLLAR	50mm	RFC50
RETROFIT FIRE COLLAR	65mm	RFC65

Retrofit fire collars are a premium collar designed to provide maximum protection against the spread of fire and smoke through walls, floors and ceiling that are penetrated by plastic pipes



UNICOLLAR

UNICOLLAR ROLL 2.5METERS	UNICOL
--------------------------	--------

PROMASTOP® UniCollar® is an intumescent device designed to maintain the integrity of the fire resistant elements through which various plastic pipes pass. It is suitable for installation in various floors and walls similar to that in which it has been tested. In the event of a fire, the intumescent material in the PROMASTOP® UniCollar® rapidly expands, closing off the plastic pipe or combustible insulation and forming an insulating barrier



FIRE PILLOW

FIRE PILLOW Small	FPLPS
FIRE PILLOW Medium	FPLPM

Trafalgar Fyreplug fire pillows, or fire barrier pillows, consist of a high temperature resistant and granulated fire stopping material enclosed in a durable and fire resistant covering, generally used for temporary fire stopping of penetrations.



FYREWRAF INSULATION

FYREWRAF 7.6m x 600mm	FW0600
FYREWRAF 7.6m x 1200mm	FW1200

FyreWrap is a foil-faced, fire protection wrap/blanket designed to provide fire rating to ducts, kitchen exhausts and fan enclosures. FyreWrap is fire tested and approved for both two and three hour ratings in accordance with AS1530.4.



FIRE DAMPER PACKING

FIRE DAMPER PACKING 3.6M 100mm	FDP100
FIRE DAMPER PACKING 3.6M 150mm	FDP150
FIRE DAMPER PACKING 3.6M 200mm	FDP200



FIRE RATED ACCESS PANEL

FIRE RATED ACCESS PANEL 708 X 538	FRAP1
FIRE RATED ACCESS PANEL 558 X 433	FRAP2
FIRE RATED ACCESS PANEL 433 X 301	FRAP3
FIRE RATED ACCESS PANEL 304 X 214	FRAP4

Fire Rated Ceiling Access Panels are manufactured in Australia and have been designed to use where fire rated protection is a requirement. They feature concealed hinges and provide lockable access to services. These panels have been fire tested in fire rated ceilings to Australian Standards AS1530.4 and have attained up to a two hour incipient fire rating for ceilings.



Easy installation

Additional plasterboard not required

Suitable for use in up to a 2 hour incipient fire rated ceiling

Fully concealed hinges

INTUMESCENT FIRE DAMPER – CIRCULAR

CIRCULAR INTUMESCENT FIRE DAMPER - 100MM	IFDR100
CIRCULAR INTUMESCENT FIRE DAMPER - 125MM	IFDR125
CIRCULAR INTUMESCENT FIRE DAMPER - 150MM	IFDR150
CIRCULAR INTUMESCENT FIRE DAMPER - 200MM	IFDR200
CIRCULAR INTUMESCENT FIRE DAMPER - 250MM	IFDR250
CIRCULAR INTUMESCENT FIRE DAMPER - 300MM	IFDR300

Creating fire-resistant compartments to subdivide a building is a recognised method to limit the spread of fire and smoke.

Intumescent fire dampers can assist with this process and largely reduce the space and time dependent spread of fire and smoke during a fire.



INTUMESCENT FIRE DAMPER – SQUARE

SQUARE INTUMESCENT FIRE DAMPER - 100 X 100	IFDS10
SQUARE INTUMESCENT FIRE DAMPER - 150 X 150	IFDS15
SQUARE INTUMESCENT FIRE DAMPER - 200 X 200	IFDS20
SQUARE INTUMESCENT FIRE DAMPER - 250 X 250	IFDS25
SQUARE INTUMESCENT FIRE DAMPER - 300 X 300	IFDS30
SQUARE INTUMESCENT FIRE DAMPER - 350 X 350	IFDS35
SQUARE INTUMESCENT FIRE DAMPER - 400 X 400	IFDS40



MAXILITE FIRE RATED BOARD – WHITE

FIRE RATED BOARD 1520 X 1000 X 30MM	FRBD30
FIRE RATED BOARD 1520 X 1000 X 40MM	FRBD40
FIRE RATED BOARD 1520 X 1000 X 60MM	FRBD60

Maxilite is a calcium silicate based lightweight, high performance fire rated board. It is completely free from asbestos, volatile organic compounds (VOCs) and ozone depleting potential (ODP).

The board is stable under high temperature stress and remains strong and crack free, even when exposed to fully developed fire.



MAXILITE FIRE RATED BOARD – BLUE PREMIUM RANGE

PREM FIRE RATED BOARD 2040 X 1220 X 30MM	FRBP30
PREM FIRE RATED BOARD 2040 X 1220 X 40MM	FRBP40
PREM FIRE RATED BOARD 2040 X 1220 X 60MM	FRBP60



FYRESAFE BATTS

FYRESAFE BATTS 1000 X 600 X 60	FSB60
--------------------------------	-------

Fyresafe FR Batts are a coated mineral fibre batt, designed for use as a fire seal for service penetrations. Consisting of a high density fibrous lamella core, sealed on both sides with a flexible fire rated ablative coating, Fyresafe Batts offer a high fire protection, along with an effective smoke and acoustic seal.

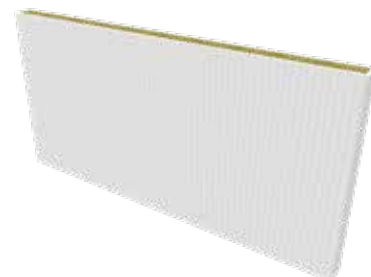

MINI FYREBOX – SQUARE AND ROUND

MINI FYREBOX SQUARE 65 X 65MM	MINFBS065
MINI FYREBOX SQUARE 100 X 100MM	MINFBS100
MINI FYREBOX ROUND 50MM DIA	MINFBR050
MINI FYREBOX ROUND 100MM DIA	MINFBR100
MINI FYREBOX ROUND 150MM DIA	MINFBR150

The Fyrebox Mini is an intumescent type product designed to prevent the spread of fire through service penetrations. It removes the need to separate service penetrations such that all contractors can run their services through the one penetration. The Fyrebox Mini is suitable for use in any building where penetrations are made through plasterboard, Hebel and masonry walls and floors for services.

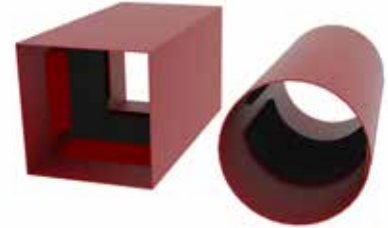

MAXI FYREBOX

MAXI FYREBOX - 350 X 125 X 250	MAXFB35
MAXI FYREBOX - 550 X 125 X 250	MAXFB55
MAXI FYREBOX - 650 X 125 X 250	MAXFB65

The Fyrebox Maxi is an intumescent type product designed to prevent the spread of fire through service penetrations. It removes the need to separate service penetrations such that all contractors can run their services through the one penetration. It features a hinged door for easy retrofit.



MAXI FYREBOX – SLAB MOUNT

MAXI FYREBOX - SLAB MOUNT 350 X 125 X 250	MAXFBSB
---	---------

The Fyrebox Slab-Mounted is a patented two-piece, clip together design. The Fyrebox system ensures that all services are adequately fire stopped. Fyrebox is a permanent system and will not require fire stopping again for the life of the building.



MAXI FYREBOX – CAST IN

MAXI FYREBOX - CAST IN 350 X 125 X 250	MAXFBC35
MAXI FYREBOX - CAST IN 550 X 125 X 250	MAXFBC55
MAXI FYREBOX - CAST IN 650 X 125 X 250	MAXFBC65



FYRESET MORTAR

FYRESET MORTAR 10KG BAG **FRM10**

Trafalgar Fyreset Mortar is a special cement based mixture formulated specifically for fire rating applications, in particular openings in fire barriers that include complicated or mixed service penetration types. It is used for fire stopping of service penetrations in wall and floor openings where a specific FRL has to be maintained.



FIRESOUND FIRE RATED SILICONE

FIRESOUND GREY SEALANT 450G CARTRIDGE **FSGC**

FIRESOUND GREY SEALANT 600ML SAUSAGE **FSGS**

Firesound is a one part, water based construction sealant for sealing joints and penetrations where fire resistance is required, or where an acoustic rated sealant is required.



FIRE MASTIC – BOSS HPE

FIRE MASTIC HPE 300ML CARTRIDGE **FMHPE**

FireMastic-HPE is a new High Pressure Exerting fire sealant to surpass all other sealants. The sealant is tested and approved to change the way firestopping is applied to pipes and penetrations.



FIRE RESISTANT EXPANDING FOAM

FIRE RESISTANT EXPANDING FOAM 500ML **FREXP500**

FulaFoam™ Fire Resistant Foam will fill cavities, is fire resistant for up to 3.5 hours and provides high acoustic insulation. FulaFoam™ Fire Resistant Foam will not shrink when cured and will provide an airtight seal, and can be cut, sanded, plastered or painted.



ELECTRICAL

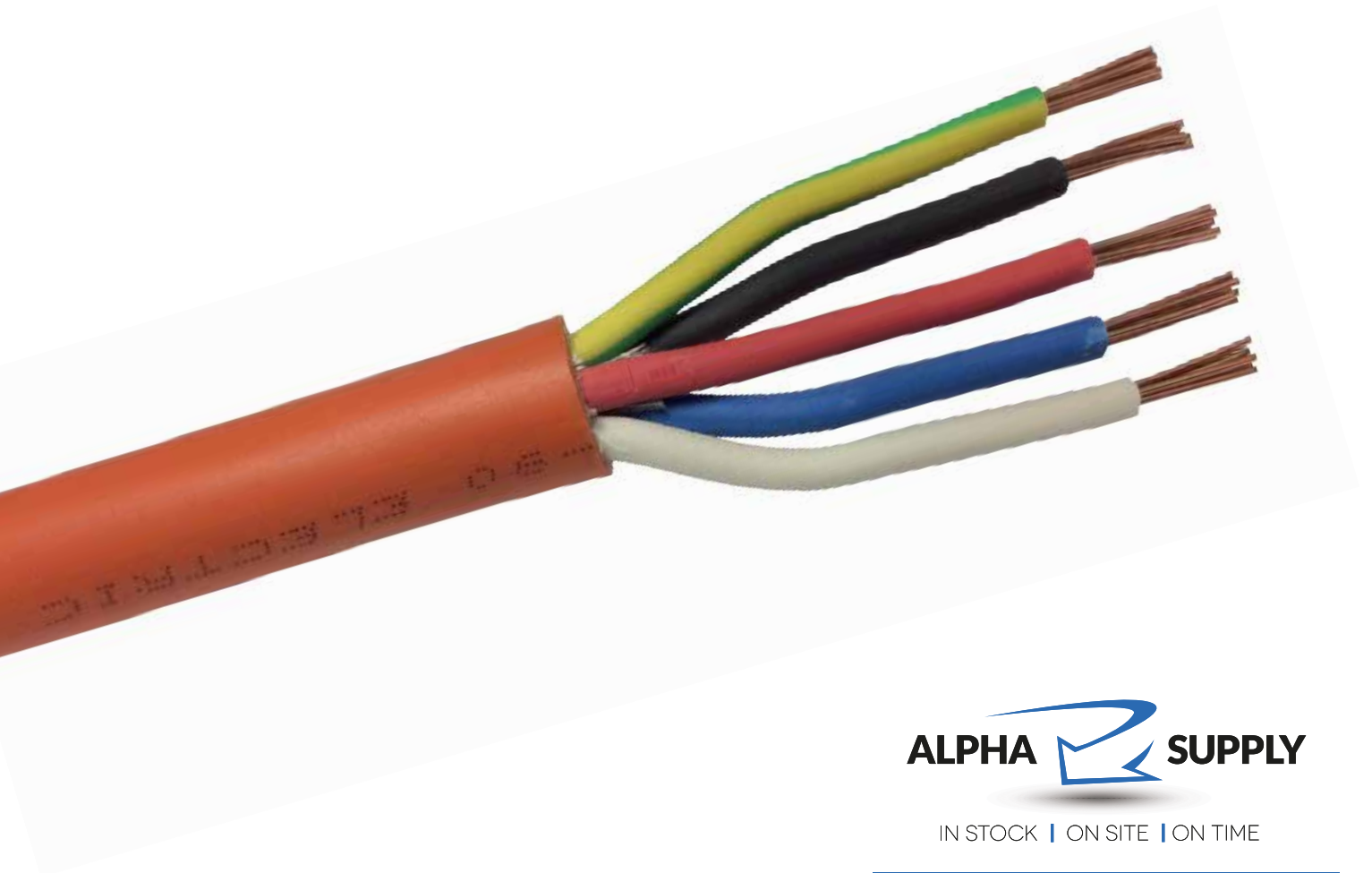

IN STOCK | ON SITE | ON TIME

ORDERING OF HVAC MATERIALS MADE EASY

Alpha Supply Pty. Ltd.
51 Assembly Dr, Tullamarine VIC 3043
PO Box 132 Tullamarine VIC 3043
P: +61 (0) 3 9445 0848
F: +61 (0) 3 9445 0849
W: www.alphasupply.com.au
E: sales@alphasupply.com.au

FLAT TPS CABLE – BLUE 3 CORE AND EARTH

CABLE FLAT BLUE 3C+E 100M-1.5mm2	FB3CE15
CABLE FLAT BLUE 3C+E 100M-2.5mm2	FB3CE25



INSTRUMENTATION CABLE

CABLE INST SHEILD 1 PR 100M-0.5mm2	ICS105
CABLE INST SHEILD 1 PR 100M-1mm	ICS110
CABLE INST SHEILD 1 PR 100M-1.5mm2	ICS115
CABLE INST SHEILD 1 PR 500M-0.5mm2	ICS505
CABLE INST SHEILD 1 PR 500M-1mm2	ICS510
CABLE INST SHEILD 1 PR 500M-1.5mm2	ICS515



FIGURE 8 CABLE

CABLE FIG 8 24/0,20	FIG8
---------------------	------



FLAT TPS CABLE – 2 CORE AND EARTH

CABLE 2C+E 100M-1.5mm2	FC2CE15
CABLE 2C+E 100M-2.5mm2	FC2CE25
CABLE 2C+E 100M-4.0mm2	FC2CE40



FLAT TPS CABLE – TWIN ACTIVE

FLAT CABLE TWIN ACTIVE 2C 2.5MM2	FCTA25
----------------------------------	--------



FLAT TPS CABLE – SDI RED

CABLE SINGLE SDI RED 2.5MM2	SDIR25
-----------------------------	--------



ORANGE CIRCULAR CABLE – 4 CORE AND EARTH

CABLE ORANGE CIRC 4C+E 100M-2.5mm ²	4CE25
CABLE ORANGE CIRC 4C+E 100M-4.0mm ²	4CE40
CABLE ORANGE CIRC 4C+E 100M-1.5mm ²	0C4CE15



ORANGE CIRCULAR CABLE – 3 CORE AND EARTH

CABLE ORANGE CIRC 3C+E 100M-1.5mm ²	0C3CE15
CABLE ORANGE CIRC 3C+E 100M-2.5mm ²	0C3CE25
CABLE ORANGE CIRC 3C+E 100M-4.0mm ²	0C3CE40
CABLE ORANGE CIRC 3C+E 100M-6.0mm ²	0C3CE60



ELECTRICAL CONDUIT – GREY 4 METER LENGTHS

CONDUIT GREY RIGID 4M-20mm x 4m	CRMD20
CONDUIT GREY RIGID 4M-25mm x 4m	CRMD25



CORRUGATED CONDUIT – 25 METER ROLLS

CONDUIT FLEXIBLE LD 25M-20mm	FC20
CONDUIT FLEXIBLE LD 25M-25mm	FC25



SOLID ELBOW 90 DEGREE – CONDUIT FITTING

SOLID ELBOW LR-20mm	SE20
SOLID ELBOW LR-25mm	SE25



STRAIGHT TEE – CONDUIT FITTING

STRAIGHT TEE-20mm	ST20
STRAIGHT TEE-25mm	ST25



INSPECTION TEE – CONDUIT FITTING

INSPECTION TEE-20mm	IT20
INSPECTION TEE-25mm	IT25



PLAIN TO SREW ADAPTOR – CONDUIT FITTING

PLAIN TO SCREW ADAPTOR-20mm	PSA20
PLAIN TO SCREW ADAPTOR-25mm	PSA25



JUNCTION BOX – LARGE

JUNCTION BOX – LARGE	JBXL
----------------------	------



HALF SADDLES TO SUIT ELECTRICAL CONDUIT

HALF SADDLE ZP 20mm	CONHS20
HALF SADDLE ZP 25mm	CONHS25



CABLE CLIPS

CABLE CLIPS 500 JAR 10MM	CC510
CABLE CLIPS 500 JAR 12MM	CC512
CABLE CLIPS 500 JAR 14MM	CC514



ADHESIVE MOUNT TIE BASE

ADHESIVE MOUNT TIE BASE PK 100 **AMTB100**



SCREW MOUNTED TIE BASE

SCREW MOUNT TIE BASE PK 100 **SMTB100**



CHRISTMAS TREE CLIPS

CHRISTMAS TREE CLIPS 6MM **CHRTC6**



SCREWED CONNECTORS

SINGLE SCREW CONNECTOR (100PK) **SSC**

DOUBLE SCREW CONNECTOR (50PK) **DSC**



WEATHERPROOF ISOLATORS

WEATHERPROOF ISOLATOR IP6620A 2P	WI20
WEATHERPROOF ISOLATOR IP6635A 1P	WI35
WEATHERPROOF ISOLATOR IP6663A 3P	WI63



CIRCUIT BREAKERS – SINGLE POLE

MCB 1 POLE 6KA 10A	MCB1610
MCB 1 POLE 6KA 16A	MCB1616
MCB 1 POLE 6KA 20A	MCB1620
MCB 1 POLE 6KA 25A	MCB1625
MCB 1 POLE 6KA 32A	MCB1632



CIRCUIT BREAKERS – THREE POLE

MCB 3 POLE 6KA 10A	MCB3610
MCB 3 POLE 6KA 16A	MCB3616
MCB 3 POLE 6KA 20A	MCB3620
MCB 3 POLE 6KA 25A	MCB3625
MCB 3 POLE 6KA 32A	MCB3632



PPE & SAFETY



ALPHA  SUPPLY

IN STOCK | ON SITE | ON TIME

ORDERING OF HVAC MATERIALS MADE EASY

Alpha Supply Pty. Ltd.
51 Assembly Dr, Tullamarine VIC 3043
PO Box 132 Tullamarine VIC 3043
P: +61 (0) 3 9445 0848
F: +61 (0) 3 9445 0849
W: www.alphasupply.com.au
E: sales@alphasupply.com.au

SAFETY GLASSES – CLEAR

WRAPAROUND SPECS CLEAR **WASC**



SAFETY GLASSES – SMOKE

WRAPAROUND SPECS SMOKE **WASS**



SAFETY GOGGLES – FOAM SEALED

SAFETY GOGGLES FOAM SEALED **SGFS**



HAND PROTECTION – BLACK KNIGHT GLOVES

- BLACK KNIGHT GLOVE-Large **BKGL**
- BLACK KNIGHT GLOVE-Medium **BKGM**
- BLACK KNIGHT GLOVE-Small **BKGS**
- BLACK KNIGHT GLOVE-X Large **BKGXL**
- BLACK KNIGHT GLOVE-XX Large **BKGXXL**



LEATHER RIGGERS GLOVE

LEATHER RIGGERS GLOVE **LRGL**



HARD HAT

HARD HAT VENTED **HHV**



HARD HAT FOAM INSERT

HARD HAT FOAM INSERT 5PK **HHVFI**



HARD HAT CHIN STRAP

HARD HAT CHIN STRAP **HCS561**



EARMUFFS

EARMUFFS 28DB **EM28DB**



EARMUFF HARD HAT MOUNT

ROCKMAN HELMET EARMUFF CLASS 5 **RMHEMC5**



QUIET BAND

QB2 QUIET BAND **QB2**
QB2 REPLACEMENT PADS PR **QB2RE**



EARPLUGS - CORDED

CORDED EARPLUGS 100PRS **CEP100**



EARPLUGS – STANDARD

EARPLUGS 200 **EP200**



KNEE PADS

GELMAX PREMIUM GEL KNEE PADS **KPGGM**



DUST MASK – P2 VALVE

DUST MASK – P2 VALVE **DMP210PK**



HALF MASK RESPIRATOR

HALF MASK RESPIRATOR **HMRESP**



SAFETY VEST

SAFETY VEST PLAIN ORG CLASS D **SVODXL**



BARRICADE TAPE – YELLOW AND BLACK

BARRICADE TAPE 75MM YLW/BLK **BT75YB**



BUNTING FLAG LINE

ORANGE BUNTING FLAG LINE - 30M **FLAG30**



EXTENSION LEAD HOOK

EXTENSION LEAD HOOK 20PK **EXTLH**



SPF50+ SUNSCREEN – 500ML BOTTLE

SPF50+ SUNCREEN - 500ML BOTTLE **SPF50**



MOBILE WORKPLACE FIRST AID KIT

FIRST AID KIT - MOBILE WORKPLACE **FAKMWP**



NITRO, OXY & ACETYLENE



ALPHA  **SUPPLY**

IN STOCK | ON SITE | ON TIME

ORDERING OF HVAC MATERIALS MADE EASY

Alpha Supply Pty. Ltd.
51 Assembly Dr, Tullamarine VIC 3043
PO Box 132 Tullamarine VIC 3043
P: +61 (0) 3 9445 0848
F: +61 (0) 3 9445 0849
W: www.alphasupply.com.au
E: sales@alphasupply.com.au

DISPOSABLE OXYGEN CYLINDER

DISPOSABLE OXYGEN CYLINDER- RED **OXYRED**



DISPOSABLE MAPP GAS CYLINDER

MAPP GAS DISPOSABLE CYLINDER **MAPCYL**



NITROGEN CYLINDER

NITROGEN INDUSTRIAL DRYD **NITROD**
 NITROGEN INDUSTRIAL DRYE **NITROE**



OXYGEN CYLINDER

OXYGEN INDUSTRIAL D **OXYD**
 OXYGEN INDUSTRIAL E **OXYE**



ACETYLENE CYLINDER

DISSOLVED ACETYLENE D **ACETD**
 DISSOLVED ACETYLENE E **ACETE**



OXY SET

OXY SET OXY SET



FLASHBACK ARRESTOR – HANDPEICE SIDE

FLASHBACK ARRESTOR ACETYLENE FLOW - HANDPEICE FBAHAC

FLASHBACK ARRESTOR OXYGEN RETURN - HANDPEICE FBAHOX



FLASHBACK ARRESTOR – REGULATOR SIDE

FLASHBACK ARRESTOR ACETYLENE FLOW - REGULATOR FBARAC

FLASHBACK ARRESTOR OXYGEN RETURN - REGULATOR FBAROX



BRAZING TIPS

BRAZING TIP LPG 10 BT10

BRAZING TIP LPG 12 BT12

BRAZING TIP LPG 15 BT15



FLINT GUN

FLINT GUN FLINTGUN

REPLACEABLE FLINTS 10PK FLINT10



NITROGEN FLOW REGULATOR

NITROGEN FLOW REG FLOREG



NITROGEN REGULATOR

NITROGEN REG 825 **NITREG**



OXYGEN REGULATOR

OXYGEN REG **OXYREG**



ACETYLENE REGULATOR

ACETYLENE REGULATOR **ACTREG**



MOBILE OXY KIT – BROMIC

MOBILE OXY KIT BROMIC **OXYKIT**



MOBILE OXY KIT – HOT DEVIL

HOT DEVIL PORTABLE OXY KIT **HDPOK**



MAPP GAS BRAZING TORCH

BRAZING TORCH MAP BERNZOMATIC **BRAZTCH**



TOOLS & MAINTENANCE EQUIPMENT



ALPHA  **SUPPLY**

IN STOCK | ON SITE | ON TIME

Alpha Supply Pty. Ltd.
51 Assembly Dr, Tullamarine VIC 3043
PO Box 132 Tullamarine VIC 3043
P: +61 (0) 3 9445 0848
F: +61 (0) 3 9445 0849
W: www.alphasupply.com.au
E: sales@alphasupply.com.au

ORDERING OF HVAC MATERIALS MADE EASY

PH2 PHILLIPS DRIVER BITS

PH2 PHILLIPS BIT-50mm	PH2PB050S
PH2 PHILLIPS BIT-75mm	PH2PB075S
PH2 PHILLIPS BIT-100mm	PH2PB100S
PH2 PHILLIPS BIT-150mm	PH2PB150S



PH2 PHILLIPS IMPACT BITS

PH2 PHILLIPS IMPACT BIT-150mm	PH2BTX150
PH2 PHILLIPS IMPACT BIT-75mm	PH2TBZ075



5/16 MAGNETIC NUTSETTERS

NUTSETTER 5/16-42mm	NS516042
NUTSETTER 5/16-65mm	NS516065
NUTSETTER 5/16-150mm	NS516150



3/8 MAGNETIC NUTSETTERS

NUTSETTER 3/8-65mm	NS38065
NUTSETTER 3/8-150mm	NS38150



MASONARY SDS BITS

SDS PLUS MASONARY BIT-10mm x 160mm	SDSPB10160
SDS PLUS MASONARY BIT-12mm x 160mm	SDSPB12160
SDS PLUS MASONARY BIT-18mm x 200mm	SDSPB18200
SDS PLUS MASONARY BIT-5mm x 110mm	SDSPB50110
SDS PLUS MASONARY BIT-5mm x 160mm	SDSPB50160
SDS PLUS MASONARY BIT-6mm x 110mm	SDSPB60110
SDS PLUS MASONARY BIT-6mm x 160mm	SDSPB60160
SDS PLUS MASONARY BIT-6.5mm x 110mm	SDSPB65110
SDS PLUS MASONARY BIT-6.5mm x 160mm	SDSPB65160
SDS PLUS MASONARY BIT-8mm x 160mm	SDSPB80160



DROP IN SETTING TOOL

DROP IN SETTING TOOL LIP M10	DAI0M10010
------------------------------	------------



DROP IN SETTING TOOLKIT

DROP IN SETTING TOOLKIT M10X30	DISKIT
--------------------------------	--------



DEEP IMPACT SOCKET

DEEP IMPACT SOCKET 13mm	DIS13
DEEP IMPACT SOCKET 15mm	DIS15
DEEP IMPACT SOCKET 16mm	DIS16
DEEP IMPACT SOCKET 17mm	DIS17
SOCKET ADAPTOR 1/4in Hex - 1/2in Sq x 70mm	SOCAD13



METAL CUT OFF BLADES

CUTTING DISC-100 x 1.0 x 16mm	MCD100
CUTTING DISC-115 x 1.0 x 22mm	MCD115
CUTTING DISC-125 x 1.0 x 22mm	MCD125
CUTTING DISC-230 x 2.0 x 22mm	MCD230
CUTTING DISC-355 x 3.0 x 25.4mm	MCD355



METAL SONIC BLADE

MSB115-A0907571-METAL SONIC BLADE-115mm	MSB115
MSB125-A0907572-METAL SONIC BLADE-125mm	MSB125



MULTI USE RAPTOR TURBO BLADES

RTB115-A0909321-RAPTOR TURBO BLADE-115mm	RTB115
RTB125-A0909322-RAPTOR TURBO BLADE-125mm	RTB125



Suitable for cured concrete/ reinforced, clay bricks, terracotta roof tiles, granite, bluestone, steel pipe, tube and hebel block

SPADE BITS

SPADE BIT-10mm	SB10
SPADE BIT-12mm	SB12
SPADE BIT-16mm	SB16
SPADE BIT-22mm	SB22
SPADE BIT-25mm	SB25
SPADE BIT-32mm	SB32
SPADE BIT-40mm	SB40



SPADE BIT – 8 PIECE SET

SPADE BIT 8 PIECE SET (10,12,16,20,22,25,32MM)	SBS8
--	------



HOLESAWS

HOLESAW 16mm	HSV016
HOLESAW 19mm	HSV019
HOLESAW 20mm	HSV020
HOLESAW 22mm	HSV022
HOLESAW 25mm	HSV025
HOLESAW 32mm	HSV032
HOLESAW 35mm	HSV035
HOLESAW 38mm	HSV038
HOLESAW 40mm	HSV040
HOLESAW 44mm	HSV044
HOLESAW 46mm	HSV046
HOLESAW 51mm	HSV051
HOLESAW 57mm	HSV057
HOLESAW 60mm	HSV060
HOLESAW 64mm	HSV064
HOLESAW 67mm	HSV067
HOLESAW 70mm	HSV070
HOLESAW 73mm	HSV073
HOLESAW 76mm	HSV076
HOLESAW 83mm	HSV083
HOLESAW 86mm	HSV086
HOLESAW 89mm	HSV089
HOLESAW 92mm	HSV092
HOLESAW 95mm	HSV095
HOLESAW 98mm	HSV098
HOLESAW 100mm	HSV100
HOLESAW 102mm	HSV102
HOLESAW 105mm	HSV105
HOLESAW 114mm	HSV114
HOLESAW 152mm	HSV152



HOLESAW ARBOR

HOLESAW ARBOR-Large suits 32mm and over	HSAL
HOLESAW ARBOR-Small suits 30mm and under	HSAS



STEP DRILLS

STEP DRILL-4-12mm	SD0412
STEP DRILL-1/4-3/4inch	SD0619
STEP DRILL-6-30mm	SD0630
STEP DRILL-6-39mm	SD0639



WOOD AUGERS

10MM TURBOMAX WOOD AUGER	WAGR10
13MM TURBOMAX WOOD AUGER	WAGR13
16MM TURBOMAX WOOD AUGER	WAGR16
19MM TURBOMAX WOOD AUGER	WAGR19
20MM TURBOMAX WOOD AUGER	WAGR20
22MM TURBOMAX WOOD AUGER	WAGR22
25MM TURBOMAX WOOD AUGER	WAGR25
32MM TURBOMAX WOOD AUGER	WAGR32



EXTENSION BAR – SUITS WOOD AUGER

EXT BAR SUIT WOOD AUGER-305mm	EBWA305
-------------------------------	---------



EXTENSION BAR – QUICK RELEASE

QUICK RELEASE EXT BAR 1/4IN-150mm	EB1415
QUICK RELEASE EXT BAR 1/4IN-300mm	EB1430



HSS DRILL BITS – DOUBLE ENDED

HSSDE18	HSSDE18
HSSDE30	HSSDE30
HSSDE316	HSSDE316
HSSDE532	HSSDE532



HSS JOBBER DRILL BITS

HSS JOBBER DRILL BIT-4mm	HSSJ040
HSS JOBBER DRILL BIT-5mm	HSSJ050
HSS JOBBER DRILL BIT-6mm	HSSJ060
HSS JOBBER DRILL BIT-8mm	HSSJ080
HSS JOBBER DRILL BIT-10mm	HSSJ100
HSS JOBBER DRILL BIT-10.5mm	HSSJ105
HSS JOBBER DRILL BIT-11mm	HSSJ110
HSS JOBBER DRILL BIT-12mm	HSSJ120



HSS DRILL BITS – REDUCED SHANK

REDUCED SHANK BIT HSS 13mm	HSSRS13
REDUCED SHANK BIT HSS 20mm	HSSRS20



COMPLETE HSS DRILL BIT SET

HSS DRILL SET 25 PIECE 1-13MM	HSSSET
-------------------------------	---------------



QUICK CHANGE HSS DRILL BIT

QUICK CHANGE HSS DRILL BIT 5mm	HSSQC50
QUICK CHANGE HSS DRILL BIT 3.2mm	HSSQS32



WIRE BRUSH WHEEL – 75MM

WHEEL WIRE BRUSH 75mm	WWB75
-----------------------	--------------



SABRE SAW – METAL

SABRE SAW BLADE METAL 150MM	SSBM150
SABRE SAW BLADE METAL 230MM	SSBM230
SABRE SAW BLADE METAL 300MM	SSBM300



SABRE SAW – WOOD

SABRE SAW BLADE WOOD 150MM	SSBW150
SABRE SAW BLADE WOOD 225MM	SSBW230
SABRE SAW BLADE WOOD 300MM	SSBW300



JIGSAW BLADES

JIGSAW BLADE EURO TIMBER 6T	JB06
JIGSAW BLADE EURO METAL 21T	JB21



THREADED ROD CUTTER

THREADED ROD CUTTER M10	TRC10
THREADED ROD CUTTER M12	TRC12



THEADED ROD CUTTER REPLACEMENT BLADES

ROD CUTTER REPLACEMENT BLADES M10	TRCB10
ROD CUTTER REPLACEMENT BLADES M12	TRCB12



STUD PUNCH KIT

METAL STUD PUNCH KIT	MSPKIT
----------------------	--------



PLASTIC STUD GROMMETS – 32MM

PLASTIC STUD GROMMETS 32MM X QTY 100	PSG32
--------------------------------------	-------



IBEAMI LED WORK LIGHT

IBEAMI LED WORK LIGHT	IBLEDWL
-----------------------	---------



IBEAMI LED HEAD LIGHT

IBEAMI LED HEAD LIGHT	IBLEDHL
-----------------------	---------



BATTERIES

AA BATTERIES	AABATT
AAA BATTERIES	AAABATT



PERMANENT MARKERS – BLACK

PERMANENT MARKER -BLACK	PMBLACK
-------------------------	---------



RETRACTABLE PERMANENT MARKER – BLACK

RETRACTABLE PERMANENT MARKER – BLACK	RPMBK
--------------------------------------	-------



WHITE PAINT MARKER

WHITE PAINT MARKER	WPMWH
--------------------	-------



BUILDERS PENCIL

BUILDERS PENCIL (EACH)	PENCIL
------------------------	--------



INTERNAL POLY BENDERS

POLY BENDER 3/8	PB10
POLY BENDER 1/2	PB13
POLY BENDER 5/8	PB16



BENDING SPRINGS

YELLOW JACKET O.D. BENDING SPRING 3/8	YJBS10
YELLOW JACKET O.D. BENDING SPRING 1/2	YJBS13
YELLOW JACKET O.D. BENDING SPRING 5/8	YJBS16
YELLOW JACKET O.D. BENDING SPRING 3/4	YJBS19



LEVER BENDERS – YELLOW JACKET

LEVER BENDER YJ3/8	YJLB10
LEVER BENDER YJ 1/2	YJLB13
LEVER BENDER YJ 5/8	YJLB16
LEVER BENDER YJ3/4	YJLB19
LEVER BENDER YJ7/8	YJLB22
3 IN 1 BENDERYJ	YJB3IN1



RATCHET HAND BENDER – YELLOW JACKET

RATCHET HAND BENDER YJRB60331



EXPANDER KIT – YELLOW JACKET

EXPANDER KIT COMPLETE 3/8-1-1/8 YJ	Y60407
EXPANDER HEAD PREM YJ 3/8	YJEH10
EXPANDER HEAD PREM YJ 1/2	YJEH13
EXPANDER HEAD PREM YJ 5/8	YJEH16
EXPANDER HEAD PREM YJ 3/4	YJEH19
EXPANDER HEAD PREM YJ 7/8	YJEH22
EXPANDER HEAD PREM YJ 1 1/8	YJEH28
EXPANDER HEAD PREM YJ 1 3/8	YJEH35
EXPANDER HEAD PREM YJ 1-5/8	YJEH42



HYDRAULIC EXPANDER KIT – YELLOW JACKET

HYDRAULIC EXPENDER KIT YJ YJ60493



ELECTRIC/HAND OPERATED FLARING TOOL – YELLOW JACKET

ECCENTRIC CONE FLARE TOOL DRILL/HAND YJ YJ60241

The aluminum body of the YELLOW JACKET Lightweight Electric/Manual Flaring Tool makes it half the weight of traditional steel designs. For super fast flaring, remove top manual handle and replace with electric drill drive.



For use with electric/power drill (with torque adjusted function only).

DELUXE FLARING TOOL – YELLOW JACKET

DELUXE FLARE TOOL YJ YJ60278



STANDARD FLARING TOOL – YELLOW JACKET

ECCENTRIC CONE FLARE TOOL YJ YJ60295



SWAGING AND FLARING TOOL KIT – YELLOW JACKET

FLARE/SWAGE KIT LW YJ YJ60430



TUBE CUTTERS – YELLOW JACKET

- MINI TUBE CUTTER 1/8 TO 5/8 YJ601YJ60
- MINI TUBE CUTTER 1/4 TO 7/8 YJ60121
- MINI TUBE CUTTER 1/4 TO 1 1/8 YJ60142
- BLADE CUTTER WHEEL 120 YJ60120
- TUBE CUTTER 1/8 TO 1-1/8 YJ YJ60101
- TUBE CUTTER 1/4 TO 1-5/8 YJ YJ60102
- LARGE TUBE CUTTER 3/8 TO 2-5/8 YJ60139
- CUTTER WHEEL TO SUIT 100 YJ60100
- BLADE CUTTER WHEEL 120 YJ60120



INNER-OUTER REAMER

INNER-OUTER REAMER YJ60161



PREMIUM PENCIL DEBURRING TOOL – YELLOW JACKET

DEBURRING TOOL YJ	YJ60163
DEBURRING TOOL BLADE	YJ60164



PENCIL DEBURRING TOOL

PENCIL DEBURRING TOOL	PDBT
-----------------------	------



MANTOOTH WIRELESS PRESSURE GAUGE

YJMT MANTOOTH MODULE YJ	Single	YJMT1
YJMT MANTOOTH MODULE YJ	Double	YJMT2

Wireless connection to your smart device (iPhone, iPad, Android compatible). Test system without losing refrigerant (no hoses and manifolds necessary). Rechargeable lithium polymer battery with 10 hours battery life



GAUGE MANIFOLDS

TITAN GAUGE MANIFOLD YJ 2V R410A	YJ49814
TITAN GAUGE MANIFOLD YJ 2V R22	YJ49812
GAUGE 80MM R32/R410A80mm Red	G8032410R



PROTECTIVE GAUGE BOOTS

GAUGE BOOTS SET 3.1/8"	GBSET
------------------------	-------



CHARGING HOSES

CHARGING HOSE 72" 1/4-5/16 BLUE	CH14516B
CHARGING HOSE 72" 1/4-5/16 RED	CH14516R
CHARGING HOSE 72" 1/4-5/16 YELLOW	CH14516Y
CHARGING HOSE 3 PK 42826 72"	CH3PK1472
R410A HOSES 3 PACK 72"	CH3PK410A72
CHARGING HOSE 3 PK 42491 R410A C/W BALL VALVE 60"	CH3PK51660
HOSE GASKETS 10PK SUIT 1/4&5/16	YJ19020



SCREWED DEPRESSOR

5/16 MSAE SCHR X 1/4 FSAE DEPRESSOR	ABR14F
1/4 MSAE SCHR X 5/16 FSAE DEPRESSOR	ABR14M



SERVICE BALL VALVE

SERVICE BALL VALVE 1/4" FF X 5/16" MF	SBV14516
SERVICE BALL VALVE 5/16" FF X 1/4" MF	SBV51614
SERVICE BALL VALVE 5/16" FF X 5/16" MF	SBV516516



VACUUM GAUGE – SUPCO

SUPCO DIGITAL VAC GAUGE	MFOP
-------------------------	------



VACUUM GAUGE – YELLOW JACKET

YJ OMNI DIGITAL VAC GAUGE 1/4	YJDVG14
-------------------------------	---------



CHARGING SCALES – YELLOW JACKET

100KG CHARGING SCALE	YJCS100
----------------------	---------



LEAK DETECTOR – YELLOW JACKET

LEAK DETECTOR ACCUPROBE YJ YJ69337

ACCUPROBE SENSOR & FILTER YJ69384



DIGITAL THERMOMETER

DIGI ALARM THERMOMETER YJDIGI



DIGITAL AIRFLOW METER

AIRFLOW METER AABM1



Sends reports by email

Compatible with smartphones

Measures airflow in LFM, CFM, CMH and LMS

INFRARED THERMOMETER – YELLOW JACKET

THERMOMETER IR YJIRT



VACUUME PUMP – YELLOW JACKET

SUPEREVAC PUMP 170L/M 6CFM YJVP93564

SUPEREVAC PUMP 310L/M 11CFM YJVP93598



VACUUM PUMP – 35LTR 2 STAGE

VACUUM PUMP 35LT **VP35**



VACUUM PUMP OIL

VACUUM PUMP OIL 1LT **VPO1**



RECOVERY UNIT – YELLOW JACKET

RECOVERY EACH XLT JY **JYXLT**



OIL PUMP – YELLOW JACKET

MAX FLOW OIL PUMP **MFOPU**



VALVE CORE REMOVER

VALVE CORE TOOL & 6 CORES **VCT6C**



FIN COMB SET

FIN COMB SET 6PCE **FINCOM**



OXY SET

OXY SET	OXY SET
---------	---------



FLASHBACK ARRESTOR – HANDPEICE SIDE

FLASHBACK ARRESTOR ACETYLENE FLOW - HANDPEICE	FBAHAC
FLASHBACK ARRESTOR OXYGEN RETURN - HANDPEICE	FBAHOX



FLASHBACK ARRESTOR – REGULATOR SIDE

FLASHBACK ARRESTOR ACETYLENE FLOW - REGULATOR	FBARAC
FLASHBACK ARRESTOR OXYGEN RETURN - REGULATOR	FBAROX



BRAZING TIPS

BRAZING TIP LPG 10	BT10
BRAZING TIP LPG 12	BT12
BRAZING TIP LPG 15	BT15



FLINT GUN

FLINT GUN	FLINTGUN
REPLACEABLE FLINTS 10PK	FLINT10



NITROGEN FLOW REGULATOR

NITROGEN FLOW REG	FLOREG
-------------------	--------



NITROGEN REGULATOR

NITROGEN REG 825 **NITREG**



OXYGEN REGULATOR

OXYGEN REG **OXYREG**



ACETYLENE REGULATOR

ACETYLENE REGULATOR **ACTREG**



MOBILE OXY KIT – BROMIC

MOBILE OXY KIT BROMIC **OXYKIT**



MOBILE OXY KIT – HOT DEVIL

HOT DEVIL PORTABLE OXY KIT **HDPOK**



MAPP GAS BRAZING TORCH

BRAZING TORCH MAP BERNZOMATIC **BRAZTCH**



DISPOSABLE OXYGEN CYLINDER

DISPOSABLE OXYGEN CYLINDER- RED **OXYRED**



DISPOSABLE MAPP GAS CYLINDER

MAPP GAS DISPOSABLE CYLINDER **MAPCYL**



INSPECTION MIRROR

INSPECTION MIRROR ROUND 30mm **IMR30**

INSPECTION MIRROR ROUND 50mm **IMR50**



CAULKING GUN

CAULKING GUN **CAUGUN**



SAUSAGE CAULKING GUN

SAUSAGE CAULKING GUN 378MM **SACAUL**



SPIRIT LEVEL

BOX SPIRIT LEVEL 300MM **LEV0300**

BOX SPIRIT LEVEL 600MM **LEV0600**

BOX SPIRIT LEVEL 1200MM **LEV1200**



RATCHET WRENCH

RATCHET WRENCH STANDARD YJ60613



TAPE MEASURE

TAPE MEASURE 8M TM8M



PLASTER SAW

PLASTER JAB SAW PJSAW



ULTRA GRIP KNIFE

ULTRA GRIP UTILITY KNIFE SGUKNI



REPLACEMENT KNIFE BLADES

REPLACEMENT KNIFE BLADES RKB10PK



CONDUIT CUTTERS

CONDUIT CUTTERS CONCUT



COMBINATION PLIERS

COMBINATION PLIERS **COPLIER**



LONG NOSED PLIERS

LONG NOSED PLIERS **LNPLIER**



MULTIGRIP PLIERS

MULTIGRIP PLIERS **MGPLIER**



SIDE CUTTERS

SIDE CUTTERS **SIDCUT**



CLAW HAMMER

PRO CLAW HAMMER 200Z **CLAHAM**



ADJUSTABLE WRENCH

ADJUSTABLE WRENCH 150mm	AW150
ADJUSTABLE WRENCH 200mm	AW200
ADJUSTABLE WRENCH 250mm	AW250
ADJUSTABLE WRENCH 300mm	AW300



DIGITAL ADJUSTABLE TORQUE WRENCH

DIGITAL ADJUSTABLE TORQUE WRENCH **YJTORCH**

The YELLOW JACKET® Adjustable Digital Torque Wrench captures and displays torque measurement in real time mode, providing users with unprecedented levels of control and accuracy.



TIN SNIPS

AVIATION SNIPS LEFT **ASNIPL**

AVIATION SNIPS RIGHT **ASNIPR**

AVIATION SNIPS STRAIGHT **ASNIPS**



HACKSAW

HACKSAW 300MM **HS300**



HACKSAW BLADES – 300MM

HACKSAW BLADE 300MM-18TPI **HSB18**

HACKSAW BLADE 300MM-24TPI **HSB24**

HACKSAW BLADE 300MM-32TPI **HSB32**



SCREWDRIVER SET – 11 PIECE

SCREWDRIVER SET – 11 PIECE **SDRIV**



ELECTRICAL SCREWDRIVER SET

ELECTRICAL SCREWDRIVER SET 6 PCE **EDRIV**



CABLE TIE TENSIONING TOOL

CABLE TIE TENSIONER TOOL HD 9MM **CTTHD**



STRING LINE

STRING LINE 50M **SLINE**



EXACTAPAK

EXACTAPAK TOOLBOX ORGANISER **EXACTAPAK**



MULTI 10

MULTI 10 TOOLBOX ORGANISER **MULTI10**



EXTENSION LEAD HOOK

EXTENSION LEAK HOOK 20PK **EXTLH**



EXTENSION LEAD

30M EXTENSION LEAD **EXT30M**



RAGS

BAG OF RAGS 10KG **RAGSB10**



MULTI PURPOSE CLEANER

MULTI PURPOSE CLEANER SPRAY **MPCLEAN**



METHYLATED SPIRITS

METHYLATED SPIRITS 1LT **METHO**



NYLOG

NYLOG THREAD SEALANT HFC 30ML **NYLOGB**



ZOOM SPOUT OIL

ZOOM SPOUT OIL **ZOOMS**



LEAK DETECTOR – BIG BLUE

BLUE LEAK DETECTOR 600ml **BBLD0600**

BLUE LEAK DETECTOR 1000ml **BBLD1000**



HEAT SHEILD

HEAT SHEILD 900ml **HEATS0900**



COIL DEGREASER

VIPER AEROSOL COIL DEGREASER **VIPDEG**



LADDER CHAIN – PER METER

CHAIN MED LINKGAL 8mm **CHMLG8**



BRASS PADLOCK

BRASS GENERAL PADLOCK **PLGBR**



HALOGEN GLOBE

GLOBE LINEAR HALOGEN 500W **HALOG500**



MALCO METAL HOLE CUTTER

MALCO METAL HOLE CUTTER 51-305MM **MALMHC1**

MALCO METAL HOLE CUTTER 51-508MM **MALMHC2**

MALCO REPLACEMENT BLADES TS1 **TS1RB**



MALCO HIGH LEVERAGE TIE TOOL

MALCO HIGH LEVERAGE TIE TOOL **MALTT**



MALCO 5 BLADE CRIMPER

REDLINE 5 BLADE CRIMPER **RL5BC**



MALCO TURBO SHEAR

TURBO SHEAR HD METAL **TSHDMET**

TURBO SHEAR METAL **TSMETAL**



ELECTRICAL POWER BOX

ELECTRICAL SAFETY POWER BOX – 4 WAY **4WEPB**



SITE BOX

SITE BOX 1215 X 610 X 605MM **SBYL1215**



STEEL STRAP 19MM

DURA-GRIP SNAP-ON STEEL STRAP 19MM **STST19**



SNAP ON SEAL

DURA-GRIP SNAP ON SEAL 19MM **STSO19**

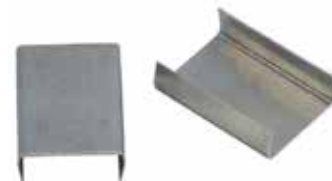

TENSIONING TOOL – HEAVY DUTY

HEAVY DUTY TENSIONING TOOL FOR STEEL 19MM **TTHDST19**



SEALING TOOL FOR SNAP ON SEAL

D.NOTCH HAND SEALER - HEAVY DUTY **STHSHD**



LASER MEASURERS & SITE STORAGE



ALPHA  **SUPPLY**

IN STOCK | ON SITE | ON TIME

Alpha Supply Pty. Ltd.
51 Assembly Dr, Tullamarine VIC 3043
PO Box 132 Tullamarine VIC 3043
P: +61 (0) 3 9445 0848
F: +61 (0) 3 9445 0849
W: www.alphasupply.com.au
E: sales@alphasupply.com.au

DEWALT® CROSS LINE LASER

DEWALT® CROSS LINE LASER	DW088K-XE
DEWALT® GREEN BEAM CROSS LINE LASER	DW088CG-XJ



DEWALT® TWIN CROSS LINE LASER

DEWALT® TWIN CROSS LINE LASER	DW089K-XE
-------------------------------	-----------



DEWALT® CROSS LINE LASER WITH PLUMB

DEWALT® 10.8V GREEN BEAM CROSS LINE LASER WITH PLUMB	DCE0822D1G-XE
--	---------------



DEWALT® 3600 + CROSS LINE LASER

DEWALT® 3600 + CROSS LINE LASER	DW089K-XE
---------------------------------	-----------



DEWALT® 3X3600 10.8V LASER

DEWALT® 3X3600 10.8V LASER	DCE089LR-XJ
DEWALT® 3 X 360 LASER – GREEN BEAM	DCE089D1G-XE



ORDERING OF HVAC MATERIALS MADE EASY

DEWALT® ROTARY LASER

DEWALT® DCE074 18V ROTARY LASER – BARE UNIT	DCE074NR-XJ
DEWALT® DCE079 18V Rotary Laser – w/ Battery & Charger – Green Beam	DCE079D1G-XE



DEWALT® 100M LASER DISTANCE MEASURE

DEWALT® 100M LASER DISTANCE MEASURE	DW03101-XJ
-------------------------------------	------------



DEWALT® 50M LASER DISTANCE MEASURE

DEWALT® 50M LASER DISTANCE MEASURE	DW03050-XJ
------------------------------------	------------



DEWALT® 30M LASER DISTANCE MEASURE

DEWALT® 30M LASER DISTANCE MEASURE	DW033-XJ
------------------------------------	----------



DEWALT® 9M POCKET LASER DISTANCE MEASURER

DEWALT® 9M POCKET LASER DISTANCE MEASURER	DW030PL-XJ
---	------------



DEWALT® TRIPOD

DEWALT® TRIPOD – 1/4"	DE0881-XE
DEWALT® CONSTRUCTION TRIPOD	DE0736-XJ



DEWALT® CROSS LINE LASER DETECTORS

DEWALT® CROSS LINE DETECTOR - RED	DE0892-XE
DEWALT® CROSS LINE DETECTOR - GREEN	DE0892G-XJ



DEWALT® LASER TARGETS

DEWALT® RED TARGET	DE0730-XJ
DEWALT® GREEN TARGET	DE0730G-XJ



DEWALT® GRADING ROD

DEWALT® GRADING ROD	DE0734-XJ
---------------------	-----------



DEWALT® LASE GLASSES

DEWALT® LASER GLASSES - RED	DW0714
DEWALT® LASER GLASSES - GREEN	DE0714G-XE



DEWALT® TOUGH SYSTEM

DEWALT® TOUGH SYSTEM 1-70-349

A new mobile modular storage system that allows you to quickly and easily change the combination of tools you take to work. The complete system includes the trolley and one of each size toolbox, or you can select any combination of individual units.



DEWALT® TOUGH DS CARRIER

DEWALT® TOUGH SYSTEM 1-70-324

The trolley features a locking system to secure all the loaded toolboxes, plus it can also be used to carry additional equipment and materials. The 8½"/ 216mm heavy duty rubber wheels allow easy manoeuvrability on rough terrain. When carrying the toolboxes by hand, they can also be fastened together, allowing them to be carried as a stack.

The heavy duty metal trolley has a foldable toe plate that can carry up to 330lb/150kg.



DEWALT® DS BRACKETS

DEWALT® DS BRACKETS 1-70-362

Additional brackets are required in pairs for when you need to carry more than three units at a time.



DEWALT® DS 150

DEWALT® TOOLBOX DS 150 1-70-321

Features a lid insert to carry drill bits and small components, plus interior organiser compartments for small parts storage, which are removable to make it suitable for carrying tools.



158mm x 336mm x 550mm

Maximum load capacity 60 kg

DEWALT® DS 300

DEWALT® TOOLBOX DS 300 1-70-322

Toolboxes that offer the ultimate in toughness and high impact protection, with a 4mm thick reinforced outer casing, which also features metal latches for added durability.

Toolboxes are dust tight and water jet resistant (IP65)* to withstand the most severe weather, and feature padlock eyes for lockable security.



308mm x 336mm x 550mm

Maximum load capacity 60 kg

DEWALT® DS 400

DEWALT® TOOLBOX DS 400 1-70-323



408mm x 366mm x 550mm

Maximum load capacity 60 kg



IN STOCK | ON SITE | ON TIME

Alpha Supply Pty. Ltd.
51 Assembly Dr, Tullamarine VIC 3043
PO Box 132 Tullamarine VIC 3043
P: +61 (0) 3 9445 0848
F: +61 (0) 3 9445 0849
W: www.alphasupply.com.au
E: sales@alphasupply.com.au

ORDERING OF HVAC MATERIALS MADE EASY