

PRODUCT CATALOGUE & SPECIFICATION GUIDE

BF
B7

PETROCHEMICAL FASTENERS

BF
B7



BREMICK
FASTENERS

www.bremick.com.au

CONTENTS	PAGE
COMPANY PROFILE	
Company Profile	4
Bremstud - Stud Bolt Range	6
B7, B7M, L7, L7M,	6
B16, B8 Class 1, B8 Class 2, B8M Class 1, B8M Class 2, B8T	6
Duplex, Super Duplex	6
Monel, Inconel, Hastelloy,	6
Titanium, Nickel, Zirconium, Carpenter 20, Incoloy	6
Bremstud Heavy Hex Nut Range	8
Grades 2H, 2HM, 4L, 7L, 7M	8
Grades 8, 8M, 8T	8
Duplex, Super Duplex	8
Monel, Inconel, Hastelloy,	8
Titanium, Nickel, Zirconium, Carpenter 20, Incoloy	8
Bremstud - Hexagonal Bolt Range	9
B7, B7M, L7, L7M,	9
B16, B8 Class 1, B8 Class 2, B8M Class 1, B8M Class 2, B8T	9
Duplex, Super Duplex	9
Monel, Inconel, Hastelloy,	9
Titanium, Nickel, Zirconium, Carpenter 20, Incoloy	9
Service Capabilities	10
QUALITY ASSURANCE	
Conformance Testing	16
Bremstud - Stud Bolts, Heavy Hex Nuts,, Heavy Hex Bolts	
Traceability and Product Identification Markings	18
Bremstud - Stud Bolts, Heavy Hex Nuts,, Heavy Hex Bolts	
Traceability by Manufacturing Batch	20
Product identification, conformance certification.	
Test and Inspection Process	22
Raw materials, Finished product, ISO/IEC 17025 Certification	
Metalurgical Verification Testing	24
Analysis of Alloys, XRF, Optical emission Spectrometry, Micrographic	
Corrosion Protection & Coating Conformance Testing	26
Mechanical Analysis, Accelerated Testing, Outdoor Exposure Tests	
Conformance Certification Scheme	28
Obtaining Inspection Certificates	28
Certification Process - Flow Chart	30
Certificate Availability	32

CONTENTS

PAGE

PRODUCT LISTINGS

Product Coding	34
B7 Bremstud	35
1/2" Diameter	35
5/8" Diameter	36
3/4" Diameter	38
7/8" Diameter	40
1.0" Diameter	42
1.1/8" Diameter	44
1.1/4" Diameter	46
1.3/8" Diameter	48
1.1/2" Diameter	50
1.5/8" Diameter	52
1.3/4" Diameter	54
1.7/8" Diameter	56
2.0" Diameter	57
Heavy Series Hex Nuts	58
Grade 2H	58
Grade 7	59
Grade 4	60
Grade 8	60
Grade 8M	61

TECHNICAL INFORMATION

Coating Systems	62
Hot Dipped Galvanised, Mechanically Plated (Zinc/Tin)	64
Electroplated - Zinc, Electroplated Cadmium	65
Xylar / Xylan, PTFE	66
Molybond	67
BremKote ZTX	67
BremKote EZN	68
BremKote CDX	68
BremKote ZNX	69
BremKote EZP	69
Chemical & Mechanical Properties - Stud Bolts & Heavy Hex Bolts	70
B7, B7M, L7, L7M, B16	70
B8 CL1, B8 CL2, B8M CL 1, B8M CL2	72
Mechanical Properties - Stud Bolts & Heavy Hex Bolts	75
B7	75
B16	76
L7, L7A, L7B, L7C, L70, L71, L72, L73	77
L7M, B7M	78
Class 1 - B8, B8M, B8C, B8P, B8F, B8T, B8LN, B8MLN	79
Class 2 - B8M	80
Class 2 - B8, B8C, B8P, B8F, B8T	81

CONTENTS	PAGE
TECHNICAL INFORMATION (continued)	
Dimensions - Heavy Hex Bolts	82
Chemical & Mechanical Properties - Heavy Hex Nuts	83
Grades - 2H, 2HM, 4L, 7, 7L, 7M	83
Grades - 8, 8M, 8T, 8C	84
Mechanical Properties - Heavy Hex Nuts	85
Grades - 2H, 3, 4, 4L, 7, 7L, 16	85
Grades - 2HM, 2, 6, 6F, 7M	86
Grades - 8, 8T, 8C, 9C, 9CA	87
Grade - 8M	88
Dimensions - Heavy Hex Nuts	89
Weight List - Heavy Hex Nuts	89
Weight List - Stud Bolts with 2 Heavy Hex Nuts	90
Metric / Imperial Conversion Tables	94
INSTALLATION GUIDANCE	
Stud Bolt Assembly & Tightening	96
Bolt Tightening Sequences	97
Flanges - 4 Bolt, 8 Bolt, 12 Bolt, 16 Bolt, 20 Bolt, 24 Bolt	
Torque / Tightening Coefficients	99
Bolt Tensioning & Tightening Torques	100
B7	100
B16	101
L7, L7A, L7B, L7C, L70, L71, L72, L73	102
L7M	103
Class 1 - B8, B8M, B8C, B8P, B8F, B8T, B8LN, B8MLN	104
Class 2 - B8M	105
Class 2 - B8, B8C, B8P, B8F, B8T	106
Bolting Details for Pipe Flanges - ANSI B16.5 & BS 3293	107
Temperature & Pressure Ratings for Carbon Steel Flanges	107
Raised Flange Bolting Requirements - PN20, PN50	108
Raised Flange Bolting Requirements - PN100, PN150	109
Raised Flange Bolting Requirements - PN250, PN420	110
SUMMARY OF TRADING TERMS	111

Product Coding

To facilitate simple identification of Stud Bolting products all products manufactured by Bremick Fasteners are coded using the following logic.

Example: B7 Stud UNC 1/2" dia x 150mm long with 2 x 2H Nuts

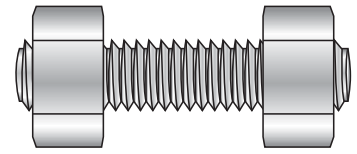

TYPE

- B = Grade B7
- L = Grade L7
- R = Rod/Bar (12')
- N = Nut

GRADE

- 7S = B7 / L7 Stud
- 16 = B16 Stud
- 8S = B8 Class 2 Stud
- 8M = B8M Class 2 Stud
- B7 = B7 Rod/Bar 12'
- L7 = L7 Rod/Bar 12'
- B8 = B8 Class 2 Rod/Bar 12'
- 2H = Grade 2H Nut
- 7H = Grade 7 Nut
- 8H = Grade 8 Nut
- 4H = Grade 4 Nut

THREAD

- C = UNC
- 8 = UN8

FINISH

- P = Plain
- G = Galvanised
- Z = Zinc Plated
- Y = Zinc Yellow
- C = Cadmium
- A = PTFE (Green)
- B = PTFE (Blue)
- D = Cadmium PTFE (Blue)
- E = Cadmium PTFE (Green)
- M = Molybond
- 4 = SS304 B8 CL2
- 6 = SS316 B8M CL2
- Q = BremKote ZTX
- R = BremKote EZN
- S = Bremkote CDX
- T = BremKote ZNX
- U = BremKote EZP

DIAMETER

- 12 = 1/2"
- 16 = 5/8"
- 20 = 3/4"
- 22 = 7/8"
- 24 = 1"
- 27 = 1. 1/8"
- 30 = 1. 1/4"
- 33 = 1. 3/8"
- 36 = 1. 1/2"
- 39 = 1. 5/8"
- 42 = 1. 3/4"
- 45 = 1. 7/8"
- 48 = 2"
- 56 = 2. 1/4"
- 60 = 2. 1/2"
- 64 = 2. 3/4"
- 72 = 3"
- 84 = 3. 1/2"

LENGTH

- 050 = 50mm
- 060 = 60mm
- 100 = 100mm
- 150 = 150mm
- 250 = 250mm
- 012 = 12 Foot
- 000 = Nut only

PACK

- 1 = Stud with Nuts
- 2 = Stud, Rod or Nut only
- 3 = Over tapped Nut only

Stud Bolt size designations

Diameter (inches)

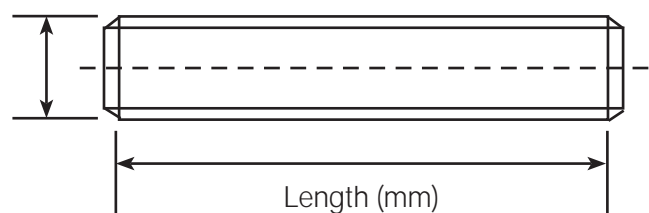

B7 BREMSTUD

BF
B7

Stud Complete with 2 x 2H Nuts

UNC PLAIN

ASTM A193/A193M & ASTM A194/A194M

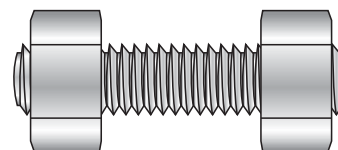

Diameter (inches)	Length (mm)	Description	Product Code	Std. Pack
1/2"	50	B7 STUD UNC 2-2H 1/2 x 50	B7SCP120501	16
	60	B7 STUD UNC 2-2H 1/2 x 60	B7SCP120601	
	65	B7 STUD UNC 2-2H 1/2 x 65	B7SCP120651	
	70	B7 STUD UNC 2-2H 1/2 x 70	B7SCP120701	
	75	B7 STUD UNC 2-2H 1/2 x 75	B7SCP120751	
	80	B7 STUD UNC 2-2H 1/2 x 80	B7SCP120801	
	90	B7 STUD UNC 2-2H 1/2 x 90	B7SCP120901	
	95	B7 STUD UNC 2-2H 1/2 x 95	B7SCP120951	
	100	B7 STUD UNC 2-2H 1/2 x 100	B7SCP121001	
	110	B7 STUD UNC 2-2H 1/2 x 110	B7SCP121101	
	115	B7 STUD UNC 2-2H 1/2 x 115	B7SCP121151	
	120	B7 STUD UNC 2-2H 1/2 x 120	B7SCP121201	
	125	B7 STUD UNC 2-2H 1/2 x 125	B7SCP121251	
	130	B7 STUD UNC 2-2H 1/2 x 130	B7SCP121301	
	140	B7 STUD UNC 2-2H 1/2 x 140	B7SCP121401	
	145	B7 STUD UNC 2-2H 1/2 x 145	B7SCP121451	
	150	B7 STUD UNC 2-2H 1/2 x 150	B7SCP121501	
	160	B7 STUD UNC 2-2H 1/2 x 160	B7SCP121601	8
	165	B7 STUD UNC 2-2H 1/2 x 165	B7SCP121651	
	170	B7 STUD UNC 2-2H 1/2 x 170	B7SCP121701	
	180	B7 STUD UNC 2-2H 1/2 x 180	B7SCP121801	
	185	B7 STUD UNC 2-2H 1/2 x 185	B7SCP121851	
	190	B7 STUD UNC 2-2H 1/2 x 190	B7SCP121901	
	195	B7 STUD UNC 2-2H 1/2 x 195	B7SCP121951	
	200	B7 STUD UNC 2-2H 1/2 x 200	B7SCP122001	
	210	B7 STUD UNC 2-2H 1/2 x 210	B7SCP122101	
	215	B7 STUD UNC 2-2H 1/2 x 215	B7SCP122151	
	220	B7 STUD UNC 2-2H 1/2 x 220	B7SCP122201	
230	B7 STUD UNC 2-2H 1/2 x 230	B7SCP122301		
235	B7 STUD UNC 2-2H 1/2 x 235	B7SCP122351		
240	B7 STUD UNC 2-2H 1/2 x 240	B7SCP122401		
250	B7 STUD UNC 2-2H 1/2 x 250	B7SCP122501		
255	B7 STUD UNC 2-2H 1/2 x 255	B7SCP122551		
260	B7 STUD UNC 2-2H 1/2 x 260	B7SCP122601		
265	B7 STUD UNC 2-2H 1/2 x 265	B7SCP122651		
275	B7 STUD UNC 2-2H 1/2 x 275	B7SCP122751		
280	B7 STUD UNC 2-2H 1/2 x 280	B7SCP122801		

CONTINUED OVER PAGE ►

B7 BREMSTUD

BREMICK

B7 BREMSTUD

Stud Complete with 2 x 2H Nuts
UNC PLAIN

ASTM A193/A193M & ASTM A194/A194M

(CONTINUED)

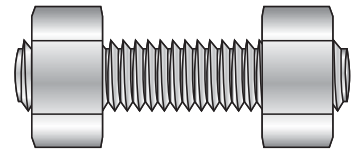

Diameter (inches)	Length (mm)	Description	Product Code	Std. Pack
1/2"	285	B7 STUD UNC 2-2H 1/2 x 285	B7SCP122851	8
	290	B7 STUD UNC 2-2H 1/2 x 290	B7SCP122901	
	300	B7 STUD UNC 2-2H 1/2 x 300	B7SCP123001	
	305	B7 STUD UNC 2-2H 1/2 x 305	B7SCP123051	1
	310	B7 STUD UNC 2-2H 1/2 x 310	B7SCP123101	
	320	B7 STUD UNC 2-2H 1/2 x 320	B7SCP123201	
	325	B7 STUD UNC 2-2H 1/2 x 325	B7SCP123251	
	330	B7 STUD UNC 2-2H 1/2 x 330	B7SCP123301	
	335	B7 STUD UNC 2-2H 1/2 x 335	B7SCP123351	
	345	B7 STUD UNC 2-2H 1/2 x 345	B7SCP123451	
	350	B7 STUD UNC 2-2H 1/2 x 350	B7SCP123501	

B7 BREMSTUD

Stud Complete with 2 x 2H Nuts
UNC PLAIN

ASTM A193/A193M & ASTM A194/A194M

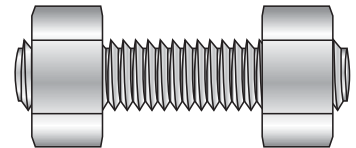

Diameter (inches)	Length (mm)	Description	Product Code	Std. Pack
5/8"	50	B7 STUD UNC 2-2H 5/8 x 50	B7SCP160501	16
	60	B7 STUD UNC 2-2H 5/8 x 60	B7SCP160601	
	65	B7 STUD UNC 2-2H 5/8 x 65	B7SCP160651	
	70	B7 STUD UNC 2-2H 5/8 x 70	B7SCP160701	
	75	B7 STUD UNC 2-2H 5/8 x 75	B7SCP160751	
	80	B7 STUD UNC 2-2H 5/8 x 80	B7SCP160801	
	85	B7 STUD UNC 2-2H 5/8 X 85	B7SCP160851	
	90	B7 STUD UNC 2-2H 5/8 x 90	B7SCP160901	
	95	B7 STUD UNC 2-2H 5/8 x 95	B7SCP160951	
	100	B7 STUD UNC 2-2H 5/8 x 100	B7SCP161001	
	105	B7 STUD UNC 2-2H 5/8 x 105	B7SCP161051	
	110	B7 STUD UNC 2-2H 5/8 x 110	B7SCP161101	
	115	B7 STUD UNC 2-2H 5/8 x 115	B7SCP161151	

CONTINUED OVER PAGE ►

B7 BREMSTUD

BF
B7

Stud Complete with 2 x 2H Nuts
UNC PLAIN

ASTM A193/A193M & ASTM A194/A194M

(CONTINUED)

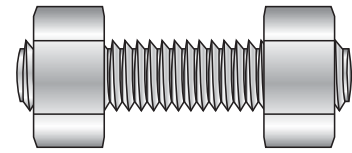

Diameter (inches)	Length (mm)	Description	Product Code	Std. Pack
5/8"	120	B7 STUD UNC 2-2H 5/8 x 120	B7SCP161201	16
	125	B7 STUD UNC 2-2H 5/8 x 125	B7SCP161251	
	130	B7 STUD UNC 2-2H 5/8 x 130	B7SCP161301	8
	140	B7 STUD UNC 2-2H 5/8 x 140	B7SCP161401	
	145	B7 STUD UNC 2-2H 5/8 x 145	B7SCP161451	
	150	B7 STUD UNC 2-2H 5/8 x 150	B7SCP161501	
	160	B7 STUD UNC 2-2H 5/8 x 160	B7SCP161601	
	165	B7 STUD UNC 2-2H 5/8 x 165	B7SCP161651	
	170	B7 STUD UNC 2-2H 5/8 x 170	B7SCP161701	
	180	B7 STUD UNC 2-2H 5/8 x 180	B7SCP161801	
	185	B7 STUD UNC 2-2H 5/8 x 185	B7SCP161851	
	190	B7 STUD UNC 2-2H 5/8 x 190	B7SCP161901	
	195	B7 STUD UNC 2-2H 5/8 x 195	B7SCP161951	
	200	B7 STUD UNC 2-2H 5/8 x 200	B7SCP162001	
	210	B7 STUD UNC 2-2H 5/8 x 210	B7SCP162101	
	215	B7 STUD UNC 2-2H 5/8 x 215	B7SCP162151	
	220	B7 STUD UNC 2-2H 5/8 x 220	B7SCP162201	
	230	B7 STUD UNC 2-2H 5/8 x 230	B7SCP162301	
	235	B7 STUD UNC 2-2H 5/8 x 235	B7SCP162351	
	240	B7 STUD UNC 2-2H 5/8 x 240	B7SCP162401	
	250	B7 STUD UNC 2-2H 5/8 x 250	B7SCP162501	
	255	B7 STUD UNC 2-2H 5/8 x 255	B7SCP162551	
	260	B7 STUD UNC 2-2H 5/8 x 260	B7SCP162601	
	265	B7 STUD UNC 2-2H 5/8 x 265	B7SCP162651	
	275	B7 STUD UNC 2-2H 5/8 x 275	B7SCP162751	
	280	B7 STUD UNC 2-2H 5/8 x 280	B7SCP162801	
	285	B7 STUD UNC 2-2H 5/8 x 285	B7SCP162851	
	290	B7 STUD UNC 2-2H 5/8 x 290	B7SCP162901	
	300	B7 STUD UNC 2-2H 5/8 x 300	B7SCP163001	
	305	B7 STUD UNC 2-2H 5/8 x 305	B7SCP163051	1
	310	B7 STUD UNC 2-2H 5/8 x 310	B7SCP163101	
	320	B7 STUD UNC 2-2H 5/8 x 320	B7SCP163201	
	325	B7 STUD UNC 2-2H 5/8 x 325	B7SCP163251	
	330	B7 STUD UNC 2-2H 5/8 x 330	B7SCP163301	
	335	B7 STUD UNC 2-2H 5/8 x 335	B7SCP163351	
345	B7 STUD UNC 2-2H 5/8 x 345	B7SCP163451		
350	B7 STUD UNC 2-2H 5/8 x 350	B7SCP163501		

B7 BREMSTUD

BREMICK

B7 BREMSTUD**Stud Complete with 2 x 2H Nuts**
UNC PLAIN

ASTM A193/A193M & ASTM A194/A194M

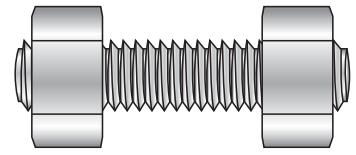

Diameter (inches)	Length (mm)	Description	Product Code	Std. Pack
3/4"	50	B7 STUD UNC 2-2H 3/4 x 50	B7SCP200501	16
	60	B7 STUD UNC 2-2H 3/4 x 60	B7SCP200601	
	65	B7 STUD UNC 2-2H 3/4 x 65	B7SCP200651	
	70	B7 STUD UNC 2-2H 3/4 x 70	B7SCP200701	
	75	B7 STUD UNC 2-2H 3/4 x 75	B7SCP200751	
	80	B7 STUD UNC 2-2H 3/4 x 80	B7SCP200801	
	90	B7 STUD UNC 2-2H 3/4 x 90	B7SCP200901	
	95	B7 STUD UNC 2-2H 3/4 x 95	B7SCP200951	8
	100	B7 STUD UNC 2-2H 3/4 x 100	B7SCP201001	
	105	B7 STUD UNC 2-2H 3/4 x 105	B7SCP201051	
	110	B7 STUD UNC 2-2H 3/4 x 110	B7SCP201101	
	115	B7 STUD UNC 2-2H 3/4 x 115	B7SCP201151	
	120	B7 STUD UNC 2-2H 3/4 x 120	B7SCP201201	
	125	B7 STUD UNC 2-2H 3/4 x 125	B7SCP201251	
	130	B7 STUD UNC 2-2H 3/4 x 130	B7SCP201301	
	135	B7 STUD UNC 2-2H 3/4 x 135	B7SCP201351	
	140	B7 STUD UNC 2-2H 3/4 x 140	B7SCP201401	
	145	B7 STUD UNC 2-2H 3/4 x 145	B7SCP201451	
	150	B7 STUD UNC 2-2H 3/4 x 150	B7SCP201501	
	160	B7 STUD UNC 2-2H 3/4 x 160	B7SCP201601	
	165	B7 STUD UNC 2-2H 3/4 x 165	B7SCP201651	
	170	B7 STUD UNC 2-2H 3/4 x 170	B7SCP201701	
	180	B7 STUD UNC 2-2H 3/4 x 180	B7SCP201801	
	185	B7 STUD UNC 2-2H 3/4 x 185	B7SCP201851	
	190	B7 STUD UNC 2-2H 3/4 x 190	B7SCP201901	
	195	B7 STUD UNC 2-2H 3/4 x 195	B7SCP201951	
	200	B7 STUD UNC 2-2H 3/4 x 200	B7SCP202001	
	210	B7 STUD UNC 2-2H 3/4 x 210	B7SCP202101	4
	215	B7 STUD UNC 2-2H 3/4 x 215	B7SCP202151	
	220	B7 STUD UNC 2-2H 3/4 x 220	B7SCP202201	
	230	B7 STUD UNC 2-2H 3/4 x 230	B7SCP202301	
	235	B7 STUD UNC 2-2H 3/4 x 235	B7SCP202351	
240	B7 STUD UNC 2-2H 3/4 x 240	B7SCP202401		
250	B7 STUD UNC 2-2H 3/4 x 250	B7SCP202501		
255	B7 STUD UNC 2-2H 3/4 x 255	B7SCP202551		
260	B7 STUD UNC 2-2H 3/4 x 260	B7SCP202601		
265	B7 STUD UNC 2-2H 3/4 x 265	B7SCP202651		

CONTINUED OVER PAGE ►

B7 BREMSTUD



Stud Complete with 2 x 2H Nuts
UNC PLAIN

ASTM A193/A193M & ASTM A194/A194M

(CONTINUED)

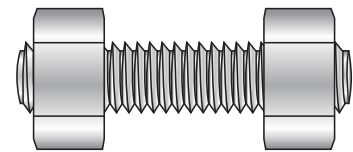

Diameter (inches)	Length (mm)	Description	Product Code	Std. Pack
3/4"	275	B7 STUD UNC 2-2H 3/4 x 275	B7SCP202751	4
	280	B7 STUD UNC 2-2H 3/4 x 280	B7SCP202801	
	285	B7 STUD UNC 2-2H 3/4 x 285	B7SCP202851	
	290	B7 STUD UNC 2-2H 3/4 x 290	B7SCP202901	
	300	B7 STUD UNC 2-2H 3/4 x 300	B7SCP203001	
	305	B7 STUD UNC 2-2H 3/4 x 305	B7SCP203051	1
	310	B7 STUD UNC 2-2H 3/4 x 310	B7SCP203101	
	320	B7 STUD UNC 2-2H 3/4 x 320	B7SCP203201	
	325	B7 STUD UNC 2-2H 3/4 x 325	B7SCP203251	
	330	B7 STUD UNC 2-2H 3/4 x 330	B7SCP203301	
	335	B7 STUD UNC 2-2H 3/4 x 335	B7SCP203351	
	345	B7 STUD UNC 2-2H 3/4 x 345	B7SCP203451	
	350	B7 STUD UNC 2-2H 3/4 x 350	B7SCP203501	
	355	B7 STUD UNC 2-2H 3/4 x 355	B7SCP203551	
	360	B7 STUD UNC 2-2H 3/4 x 360	B7SCP203601	
	370	B7 STUD UNC 2-2H 3/4 x 370	B7SCP203701	
	375	B7 STUD UNC 2-2H 3/4 x 375	B7SCP203751	
	380	B7 STUD UNC 2-2H 3/4 x 380	B7SCP203801	
	385	B7 STUD UNC 2-2H 3/4 x 385	B7SCP203851	
	395	B7 STUD UNC 2-2H 3/4 x 395	B7SCP203951	
	400	B7 STUD UNC 2-2H 3/4 x 400	B7SCP204001	
	405	B7 STUD UNC 2-2H 3/4 x 405	B7SCP204051	
	415	B7 STUD UNC 2-2H 3/4 x 415	B7SCP204151	
	420	B7 STUD UNC 2-2H 3/4 x 420	B7SCP204201	
	425	B7 STUD UNC 2-2H 3/4 x 425	B7SCP204251	
	430	B7 STUD UNC 2-2H 3/4 x 430	B7SCP204301	
	440	B7 STUD UNC 2-2H 3/4 x 440	B7SCP204401	
	445	B7 STUD UNC 2-2H 3/4 x 445	B7SCP204451	
	450	B7 STUD UNC 2-2H 3/4 x 450	B7SCP204501	
	455	B7 STUD UNC 2-2H 3/4 x 455	B7SCP204551	
	465	B7 STUD UNC 2-2H 3/4 x 465	B7SCP204651	
	470	B7 STUD UNC 2-2H 3/4 x 470	B7SCP204701	
	475	B7 STUD UNC 2-2H 3/4 x 475	B7SCP204751	
	485	B7 STUD UNC 2-2H 3/4 x 485	B7SCP204851	
490	B7 STUD UNC 2-2H 3/4 x 490	B7SCP204901		
495	B7 STUD UNC 2-2H 3/4 x 495	B7SCP204951		
500	B7 STUD UNC 2-2H 3/4 x 500	B7SCP205001		
510	B7 STUD UNC 2-2H 3/4 x 510	B7SCP205101		

BREMICK B7 BREMSTUD

B7 BREMSTUD**Stud Complete with 2 x 2H Nuts**
UNC PLAIN

ASTM A193/A193M & ASTM A194/A194M

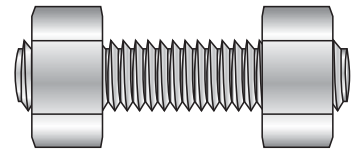

Diameter (inches)	Length (mm)	Description	Product Code	Std. Pack
7/8"	75	B7 STUD UNC 2-2H 7/8 x 75	B7SCP220751	8
	80	B7 STUD UNC 2-2H 7/8 x 80	B7SCP220801	
	90	B7 STUD UNC 2-2H 7/8 x 90	B7SCP220901	
	95	B7 STUD UNC 2-2H 7/8 x 95	B7SCP220951	
	100	B7 STUD UNC 2-2H 7/8 x 100	B7SCP221001	
	110	B7 STUD UNC 2-2H 7/8 x 110	B7SCP221101	
	115	B7 STUD UNC 2-2H 7/8 x 115	B7SCP221151	
	120	B7 STUD UNC 2-2H 7/8 x 120	B7SCP221201	
	125	B7 STUD UNC 2-2H 7/8 x 125	B7SCP221251	
	130	B7 STUD UNC 2-2H 7/8 x 130	B7SCP221301	
	140	B7 STUD UNC 2-2H 7/8 x 140	B7SCP221401	
	145	B7 STUD UNC 2-2H 7/8 x 145	B7SCP221451	
	150	B7 STUD UNC 2-2H 7/8 x 150	B7SCP221501	
	160	B7 STUD UNC 2-2H 7/8 x 160	B7SCP221601	4
	165	B7 STUD UNC 2-2H 7/8 x 165	B7SCP221651	
	170	B7 STUD UNC 2-2H 7/8 x 170	B7SCP221701	
	180	B7 STUD UNC 2-2H 7/8 x 180	B7SCP221801	
	185	B7 STUD UNC 2-2H 7/8 x 185	B7SCP221851	
	190	B7 STUD UNC 2-2H 7/8 x 190	B7SCP221901	
	195	B7 STUD UNC 2-2H 7/8 x 195	B7SCP221951	
	200	B7 STUD UNC 2-2H 7/8 x 200	B7SCP222001	
	210	B7 STUD UNC 2-2H 7/8 x 210	B7SCP222101	
	215	B7 STUD UNC 2-2H 7/8 x 215	B7SCP222151	
	220	B7 STUD UNC 2-2H 7/8 x 220	B7SCP222201	
	230	B7 STUD UNC 2-2H 7/8 x 230	B7SCP222301	
	235	B7 STUD UNC 2-2H 7/8 x 235	B7SCP222351	
	240	B7 STUD UNC 2-2H 7/8 x 240	B7SCP222401	
	250	B7 STUD UNC 2-2H 7/8 x 250	B7SCP222501	
	255	B7 STUD UNC 2-2H 7/8 x 255	B7SCP222551	
	260	B7 STUD UNC 2-2H 7/8 x 260	B7SCP222601	
	265	B7 STUD UNC 2-2H 7/8 x 265	B7SCP222651	
	275	B7 STUD UNC 2-2H 7/8 x 275	B7SCP222751	
	280	B7 STUD UNC 2-2H 7/8 x 280	B7SCP222801	
	285	B7 STUD UNC 2-2H 7/8 x 285	B7SCP222851	
	290	B7 STUD UNC 2-2H 7/8 x 290	B7SCP222901	
300	B7 STUD UNC 2-2H 7/8 x 300	B7SCP223001		
305	B7 STUD UNC 2-2H 7/8 x 305	B7SCP223051	1	

CONTINUED OVER PAGE ►

B7 BREMSTUD

BF
B7

Stud Complete with 2 x 2H Nuts

UNC PLAIN

ASTM A193/A193M & ASTM A194/A194M

(CONTINUED)

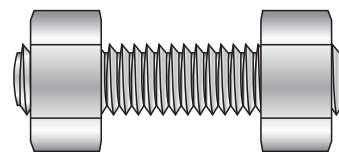

Diameter (inches)	Length (mm)	Description	Product Code	Std. Pack
7/8"	310	B7 STUD UNC 2-2H 7/8 x 310	B7SCP223101	1
	320	B7 STUD UNC 2-2H 7/8 x 320	B7SCP223201	
	325	B7 STUD UNC 2-2H 7/8 x 325	B7SCP223251	
	330	B7 STUD UNC 2-2H 7/8 x 330	B7SCP223301	
	335	B7 STUD UNC 2-2H 7/8 x 335	B7SCP223351	
	345	B7 STUD UNC 2-2H 7/8 x 345	B7SCP223451	
	350	B7 STUD UNC 2-2H 7/8 x 350	B7SCP223501	
	355	B7 STUD UNC 2-2H 7/8 x 355	B7SCP223551	
	360	B7 STUD UNC 2-2H 7/8 x 360	B7SCP223601	
	370	B7 STUD UNC 2-2H 7/8 x 370	B7SCP223701	
	375	B7 STUD UNC 2-2H 7/8 x 375	B7SCP223751	
	380	B7 STUD UNC 2-2H 7/8 x 380	B7SCP223801	
	385	B7 STUD UNC 2-2H 7/8 x 385	B7SCP223851	
	395	B7 STUD UNC 2-2H 7/8 x 395	B7SCP223951	
	400	B7 STUD UNC 2-2H 7/8 x 400	B7SCP224001	
	405	B7 STUD UNC 2-2H 7/8 x 405	B7SCP224051	
	415	B7 STUD UNC 2-2H 7/8 x 415	B7SCP224151	
	420	B7 STUD UNC 2-2H 7/8 x 420	B7SCP224201	
	425	B7 STUD UNC 2-2H 7/8 x 425	B7SCP224251	
	430	B7 STUD UNC 2-2H 7/8 x 430	B7SCP224301	
	440	B7 STUD UNC 2-2H 7/8 x 440	B7SCP224401	
	445	B7 STUD UNC 2-2H 7/8 x 445	B7SCP224451	
	450	B7 STUD UNC 2-2H 7/8 x 450	B7SCP224501	
	455	B7 STUD UNC 2-2H 7/8 x 455	B7SCP224551	
	465	B7 STUD UNC 2-2H 7/8 x 465	B7SCP224651	
	470	B7 STUD UNC 2-2H 7/8 x 470	B7SCP224701	
	475	B7 STUD UNC 2-2H 7/8 x 475	B7SCP224751	
	485	B7 STUD UNC 2-2H 7/8 x 485	B7SCP224851	
	490	B7 STUD UNC 2-2H 7/8 x 490	B7SCP224901	
	495	B7 STUD UNC 2-2H 7/8 x 495	B7SCP224951	
500	B7 STUD UNC 2-2H 7/8 x 500	B7SCP225001		
510	B7 STUD UNC 2-2H 7/8 x 510	B7SCP225101		

B7 BREMSTUD

BREMICK

B7 BREMSTUD**Stud Complete with 2 x 2H Nuts**
UNC PLAIN

ASTM A193/A193M & ASTM A194/A194M

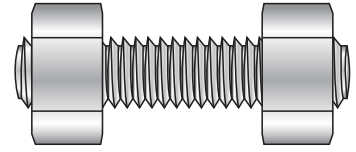

Diameter (inches)	Length (mm)	Description	Product Code	Std. Pack
1"	75	B7 STUD UNC 2-2H 1 x 75	B7SCP240751	4
	80	B7 STUD UNC 2-2H 1 x 80	B7SCP240801	
	90	B7 STUD UNC 2-2H 1 x 90	B7SCP240901	
	95	B7 STUD UNC 2-2H 1 x 95	B7SCP240951	
	100	B7 STUD UNC 2-2H 1 x 100	B7SCP241001	
	110	B7 STUD UNC 2-2H 1 x 110	B7SCP241101	
	115	B7 STUD UNC 2-2H 1 x 115	B7SCP241151	
	120	B7 STUD UNC 2-2H 1 x 120	B7SCP241201	
	125	B7 STUD UNC 2-2H 1 x 125	B7SCP241251	
	130	B7 STUD UNC 2-2H 1 x 130	B7SCP241301	
	140	B7 STUD UNC 2-2H 1 x 140	B7SCP241401	
	145	B7 STUD UNC 2-2H 1 x 145	B7SCP241451	
	150	B7 STUD UNC 2-2H 1 x 150	B7SCP241501	
	160	B7 STUD UNC 2-2H 1 x 160	B7SCP241601	
	165	B7 STUD UNC 2-2H 1 x 165	B7SCP241651	
	170	B7 STUD UNC 2-2H 1 x 170	B7SCP241701	
	180	B7 STUD UNC 2-2H 1 x 180	B7SCP241801	
	185	B7 STUD UNC 2-2H 1 x 185	B7SCP241851	
	190	B7 STUD UNC 2-2H 1 x 190	B7SCP241901	
	195	B7 STUD UNC 2-2H 1 x 195	B7SCP241951	
	200	B7 STUD UNC 2-2H 1 x 200	B7SCP242001	
	210	B7 STUD UNC 2-2H 1 x 210	B7SCP242101	
	215	B7 STUD UNC 2-2H 1 x 215	B7SCP242151	
	220	B7 STUD UNC 2-2H 1 x 220	B7SCP242201	
	230	B7 STUD UNC 2-2H 1 x 230	B7SCP242301	
	235	B7 STUD UNC 2-2H 1 x 235	B7SCP242351	
	240	B7 STUD UNC 2-2H 1 x 240	B7SCP242401	
	250	B7 STUD UNC 2-2H 1 x 250	B7SCP242501	
	255	B7 STUD UNC 2-2H 1 x 255	B7SCP242551	
	260	B7 STUD UNC 2-2H 1 x 260	B7SCP242601	
	265	B7 STUD UNC 2-2H 1 x 265	B7SCP242651	
	275	B7 STUD UNC 2-2H 1 x 275	B7SCP242751	
	280	B7 STUD UNC 2-2H 1 x 280	B7SCP242801	
285	B7 STUD UNC 2-2H 1 x 285	B7SCP242851		
290	B7 STUD UNC 2-2H 1 x 290	B7SCP242901		
300	B7 STUD UNC 2-2H 1 x 300	B7SCP243001		
305	B7 STUD UNC 2-2H 1 x 305	B7SCP243051	1	

CONTINUED OVER PAGE ►

B7 BREMSTUD

BREMSTUDBF
B7

Stud Complete with 2 x 2H Nuts
UNC PLAIN

ASTM A193/A193M & ASTM A194/A194M

(CONTINUED)

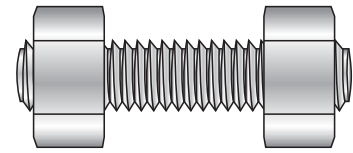

Diameter (inches)	Length (mm)	Description	Product Code	Std. Pack
1"	310	B7 STUD UNC 2-2H 1 x 310	B7SCP243101	1
	320	B7 STUD UNC 2-2H 1 x 320	B7SCP243201	
	325	B7 STUD UNC 2-2H 1 x 325	B7SCP243251	
	330	B7 STUD UNC 2-2H 1 x 330	B7SCP243301	
	335	B7 STUD UNC 2-2H 1 x 335	B7SCP243351	
	345	B7 STUD UNC 2-2H 1 x 345	B7SCP243451	
	350	B7 STUD UNC 2-2H 1 x 350	B7SCP243501	
	355	B7 STUD UNC 2-2H 1 x 355	B7SCP243551	
	360	B7 STUD UNC 2-2H 1 x 360	B7SCP243601	
	370	B7 STUD UNC 2-2H 1 x 370	B7SCP243701	
	375	B7 STUD UNC 2-2H 1 x 375	B7SCP243751	
	380	B7 STUD UNC 2-2H 1 x 380	B7SCP243801	
	385	B7 STUD UNC 2-2H 1 x 385	B7SCP243851	
	395	B7 STUD UNC 2-2H 1 x 395	B7SCP243951	
	400	B7 STUD UNC 2-2H 1 x 400	B7SCP244001	
	405	B7 STUD UNC 2-2H 1 x 405	B7SCP244051	
	415	B7 STUD UNC 2-2H 1 x 415	B7SCP244151	
	420	B7 STUD UNC 2-2H 1 x 420	B7SCP244201	
	425	B7 STUD UNC 2-2H 1 x 425	B7SCP244251	
	430	B7 STUD UNC 2-2H 1 x 430	B7SCP244301	
	440	B7 STUD UNC 2-2H 1 x 440	B7SCP244401	
	445	B7 STUD UNC 2-2H 1 x 445	B7SCP244451	
	450	B7 STUD UNC 2-2H 1 x 450	B7SCP244501	
	455	B7 STUD UNC 2-2H 1 x 455	B7SCP244551	
	465	B7 STUD UNC 2-2H 1 x 465	B7SCP244651	
	470	B7 STUD UNC 2-2H 1 x 470	B7SCP244701	
	475	B7 STUD UNC 2-2H 1 x 475	B7SCP244751	
	485	B7 STUD UNC 2-2H 1 x 485	B7SCP244851	
490	B7 STUD UNC 2-2H 1 x 490	B7SCP244901		
495	B7 STUD UNC 2-2H 1 x 495	B7SCP244951		
500	B7 STUD UNC 2-2H 1 x 500	B7SCP245001		
510	B7 STUD UNC 2-2H 1 x 510	B7SCP245101		

B7 BREMSTUD

BREMICK

B7 BREMSTUD**Stud Complete with 2 x 2H Nuts**
UN8 PLAIN

ASTM A193/A193M & ASTM A194/A194M

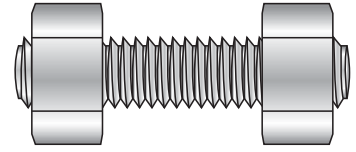

Diameter (inches)	Length (mm)	Description	Product Code	Std. Pack
1.1/8"	75	B7 STUD UN8 2-2H 1 1/8 x 75	B7S8P270751	4
	80	B7 STUD UN8 2-2H 1 1/8 x 80	B7S8P270801	
	90	B7 STUD UN8 2-2H 1 1/8 x 90	B7S8P270901	
	95	B7 STUD UN8 2-2H 1 1/8 x 95	B7S8P270951	
	100	B7 STUD UN8 2-2H 1 1/8 x 100	B7S8P271001	
	110	B7 STUD UN8 2-2H 1 1/8 x 110	B7S8P271101	
	115	B7 STUD UN8 2-2H 1 1/8 x 115	B7S8P271151	
	120	B7 STUD UN8 2-2H 1 1/8 x 120	B7S8P271201	
	125	B7 STUD UN8 2-2H 1 1/8 x 125	B7S8P271251	
	130	B7 STUD UN8 2-2H 1 1/8 x 130	B7S8P271301	
	140	B7 STUD UN8 2-2H 1 1/8 x 140	B7S8P271401	
	145	B7 STUD UN8 2-2H 1 1/8 x 145	B7S8P271451	
	150	B7 STUD UN8 2-2H 1 1/8 x 150	B7S8P271501	
	160	B7 STUD UN8 2-2H 1 1/8 x 160	B7S8P271601	
	165	B7 STUD UN8 2-2H 1 1/8 x 165	B7S8P271651	
	170	B7 STUD UN8 2-2H 1 1/8 x 170	B7S8P271701	
	180	B7 STUD UN8 2-2H 1 1/8 x 180	B7S8P271801	
	185	B7 STUD UN8 2-2H 1 1/8 x 185	B7S8P271851	
	190	B7 STUD UN8 2-2H 1 1/8 x 190	B7S8P271901	
	195	B7 STUD UN8 2-2H 1 1/8 x 195	B7S8P271951	
	200	B7 STUD UN8 2-2H 1 1/8 x 200	B7S8P272001	
	210	B7 STUD UN8 2-2H 1 1/8 x 210	B7S8P272101	
	215	B7 STUD UN8 2-2H 1 1/8 x 215	B7S8P272151	
	220	B7 STUD UN8 2-2H 1 1/8 x 220	B7S8P272201	
	230	B7 STUD UN8 2-2H 1 1/8 x 230	B7S8P272301	
	235	B7 STUD UN8 2-2H 1 1/8 x 235	B7S8P272351	
	240	B7 STUD UN8 2-2H 1 1/8 x 240	B7S8P272401	
	250	B7 STUD UN8 2-2H 1 1/8 x 250	B7S8P272501	
	255	B7 STUD UN8 2-2H 1 1/8 x 255	B7S8P272551	
	260	B7 STUD UN8 2-2H 1 1/8 x 260	B7S8P272601	
	265	B7 STUD UN8 2-2H 1 1/8 x 265	B7S8P272651	
	275	B7 STUD UN8 2-2H 1 1/8 x 275	B7S8P272751	
	280	B7 STUD UN8 2-2H 1 1/8 x 280	B7S8P272801	
285	B7 STUD UN8 2-2H 1 1/8 x 285	B7S8P272851		
290	B7 STUD UN8 2-2H 1 1/8 x 290	B7S8P272901		
300	B7 STUD UN8 2-2H 1 1/8 x 300	B7S8P273001		
305	B7 STUD UN8 2-2H 1 1/8 x 305	B7S8P273051	1	

CONTINUED OVER PAGE ►

B7 BREMSTUD

BREMSTUDBF
B7

Stud Complete with 2 x 2H Nuts

UN8 PLAIN

ASTM A193/A193M & ASTM A194/A194M

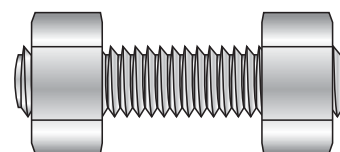
(CONTINUED)

Diameter (inches)	Length (mm)	Description	Product Code	Std. Pack
1.1/8"	310	B7 STUD UN8 2-2H 1 1/8 x 310	B7S8P273101	1
	320	B7 STUD UN8 2-2H 1 1/8 x 320	B7S8P273201	
	325	B7 STUD UN8 2-2H 1 1/8 x 325	B7S8P273251	
	330	B7 STUD UN8 2-2H 1 1/8 x 330	B7S8P273301	
	335	B7 STUD UN8 2-2H 1 1/8 x 335	B7S8P273351	
	345	B7 STUD UN8 2-2H 1 1/8 x 345	B7S8P273451	
	350	B7 STUD UN8 2-2H 1 1/8 x 350	B7S8P273501	
	355	B7 STUD UN8 2-2H 1 1/8 x 355	B7S8P273551	
	360	B7 STUD UN8 2-2H 1 1/8 x 360	B7S8P273601	
	370	B7 STUD UN8 2-2H 1 1/8 x 370	B7S8P273701	
	375	B7 STUD UN8 2-2H 1 1/8 x 375	B7S8P273751	
	380	B7 STUD UN8 2-2H 1 1/8 x 380	B7S8P273801	
	385	B7 STUD UN8 2-2H 1 1/8 x 385	B7S8P273851	
	395	B7 STUD UN8 2-2H 1 1/8 x 395	B7S8P273951	
	400	B7 STUD UN8 2-2H 1 1/8 x 400	B7S8P274001	
	405	B7 STUD UN8 2-2H 1 1/8 x 405	B7S8P274051	
	415	B7 STUD UN8 2-2H 1 1/8 x 415	B7S8P274151	
	420	B7 STUD UN8 2-2H 1 1/8 x 420	B7S8P274201	
	425	B7 STUD UN8 2-2H 1 1/8 x 425	B7S8P274251	
	430	B7 STUD UN8 2-2H 1 1/8 x 430	B7S8P274301	
	440	B7 STUD UN8 2-2H 1 1/8 x 440	B7S8P274401	
	445	B7 STUD UN8 2-2H 1 1/8 x 445	B7S8P274451	
	450	B7 STUD UN8 2-2H 1 1/8 x 450	B7S8P274501	
	455	B7 STUD UN8 2-2H 1 1/8 x 455	B7S8P274551	
	465	B7 STUD UN8 2-2H 1 1/8 x 465	B7S8P274651	
	470	B7 STUD UN8 2-2H 1 1/8 x 470	B7S8P274701	
	475	B7 STUD UN8 2-2H 1 1/8 x 475	B7S8P274751	
	485	B7 STUD UN8 2-2H 1 1/8 x 485	B7S8P274851	
	490	B7 STUD UN8 2-2H 1 1/8 x 490	B7S8P274901	
	495	B7 STUD UN8 2-2H 1 1/8 x 495	B7S8P274951	
500	B7 STUD UN8 2-2H 1 1/8 x 500	B7S8P275001		
510	B7 STUD UN8 2-2H 1 1/8 x 510	B7S8P275101		

B7 BREMSTUD

BREMICK

B7 BREMSTUD**Stud Complete with 2 x 2H Nuts**
UN8 PLAIN

ASTM A193/A193M & ASTM A194/A194M

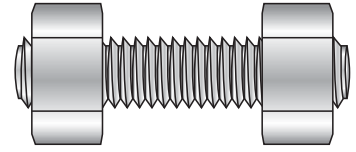

Diameter (inches)	Length (mm)	Description	Product Code	Std. Pack
1.1/4"	75	B7 STUD UN8 2-2H 1 1/4 x 75	B7S8P300751	4
	80	B7 STUD UN8 2-2H 1 1/4 x 80	B7S8P300801	
	90	B7 STUD UN8 2-2H 1 1/4 x 90	B7S8P300901	
	95	B7 STUD UN8 2-2H 1 1/4 x 95	B7S8P300951	
	100	B7 STUD UN8 2-2H 1 1/4 x 100	B7S8P301001	
	110	B7 STUD UN8 2-2H 1 1/4 x 110	B7S8P301101	
	115	B7 STUD UN8 2-2H 1 1/4 x 115	B7S8P301151	
	120	B7 STUD UN8 2-2H 1 1/4 x 120	B7S8P301201	
	125	B7 STUD UN8 2-2H 1 1/4 x 125	B7S8P301251	
	130	B7 STUD UN8 2-2H 1 1/4 x 130	B7S8P301301	
	140	B7 STUD UN8 2-2H 1 1/4 x 140	B7S8P301401	
	145	B7 STUD UN8 2-2H 1 1/4 x 145	B7S8P301451	
	150	B7 STUD UN8 2-2H 1 1/4 x 150	B7S8P301501	
	160	B7 STUD UN8 2-2H 1 1/4 x 160	B7S8P301601	
	165	B7 STUD UN8 2-2H 1 1/4 x 165	B7S8P301651	
	170	B7 STUD UN8 2-2H 1 1/4 x 170	B7S8P301701	
	180	B7 STUD UN8 2-2H 1 1/4 x 180	B7S8P301801	
	185	B7 STUD UN8 2-2H 1 1/4 x 185	B7S8P301851	
	190	B7 STUD UN8 2-2H 1 1/4 x 190	B7S8P301901	
	195	B7 STUD UN8 2-2H 1 1/4 x 195	B7S8P301951	
	200	B7 STUD UN8 2-2H 1 1/4 x 200	B7S8P302001	
	210	B7 STUD UN8 2-2H 1 1/4 x 210	B7S8P302101	
	215	B7 STUD UN8 2-2H 1 1/4 x 215	B7S8P302151	
	220	B7 STUD UN8 2-2H 1 1/4 x 220	B7S8P302201	
	230	B7 STUD UN8 2-2H 1 1/4 x 230	B7S8P302301	
	235	B7 STUD UN8 2-2H 1 1/4 x 235	B7S8P302351	
	240	B7 STUD UN8 2-2H 1 1/4 x 240	B7S8P302401	
	250	B7 STUD UN8 2-2H 1 1/4 x 250	B7S8P302501	
	255	B7 STUD UN8 2-2H 1 1/4 x 255	B7S8P302551	
	260	B7 STUD UN8 2-2H 1 1/4 x 260	B7S8P302601	
	265	B7 STUD UN8 2-2H 1 1/4 x 265	B7S8P302651	
	275	B7 STUD UN8 2-2H 1 1/4 x 275	B7S8P302751	
	280	B7 STUD UN8 2-2H 1 1/4 x 280	B7S8P302801	
285	B7 STUD UN8 2-2H 1 1/4 x 285	B7S8P302851		
290	B7 STUD UN8 2-2H 1 1/4 x 290	B7S8P302901		
300	B7 STUD UN8 2-2H 1 1/4 x 300	B7S8P303001		
305	B7 STUD UN8 2-2H 1 1/4 x 305	B7S8P303051	1	

CONTINUED OVER PAGE ►

B7 BREMSTUD

BREMSTUDBF
B7

Stud Complete with 2 x 2H Nuts

UN8 PLAIN

ASTM A193/A193M & ASTM A194/A194M

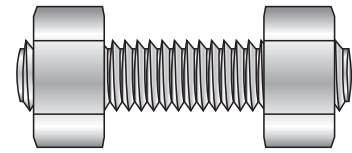
(CONTINUED)

Diameter (inches)	Length (mm)	Description	Product Code	Std. Pack
1.1/4"	310	B7 STUD UN8 2-2H 1 1/4 x 310	B7S8P303101	1
	320	B7 STUD UN8 2-2H 1 1/4 x 320	B7S8P303201	
	325	B7 STUD UN8 2-2H 1 1/4 x 325	B7S8P303251	
	330	B7 STUD UN8 2-2H 1 1/4 x 330	B7S8P303301	
	335	B7 STUD UN8 2-2H 1 1/4 x 335	B7S8P303351	
	345	B7 STUD UN8 2-2H 1 1/4 x 345	B7S8P303451	
	350	B7 STUD UN8 2-2H 1 1/4 x 350	B7S8P303501	
	355	B7 STUD UN8 2-2H 1 1/4 x 355	B7S8P303551	
	360	B7 STUD UN8 2-2H 1 1/4 x 360	B7S8P303601	
	370	B7 STUD UN8 2-2H 1 1/4 x 370	B7S8P303701	
	375	B7 STUD UN8 2-2H 1 1/4 x 375	B7S8P303751	
	380	B7 STUD UN8 2-2H 1 1/4 x 380	B7S8P303801	
	385	B7 STUD UN8 2-2H 1 1/4 x 385	B7S8P303851	
	395	B7 STUD UN8 2-2H 1 1/4 x 395	B7S8P303951	
	400	B7 STUD UN8 2-2H 1 1/4 x 400	B7S8P304001	
	405	B7 STUD UN8 2-2H 1 1/4 x 405	B7S8P304051	
	415	B7 STUD UN8 2-2H 1 1/4 x 415	B7S8P304151	
	420	B7 STUD UN8 2-2H 1 1/4 x 420	B7S8P304201	
	425	B7 STUD UN8 2-2H 1 1/4 x 425	B7S8P304251	
	430	B7 STUD UN8 2-2H 1 1/4 x 430	B7S8P304301	
	440	B7 STUD UN8 2-2H 1 1/4 x 440	B7S8P304401	
	445	B7 STUD UN8 2-2H 1 1/4 x 445	B7S8P304451	
	450	B7 STUD UN8 2-2H 1 1/4 x 450	B7S8P304501	
	455	B7 STUD UN8 2-2H 1 1/4 x 455	B7S8P304551	
	465	B7 STUD UN8 2-2H 1 1/4 x 465	B7S8P304651	
	470	B7 STUD UN8 2-2H 1 1/4 x 470	B7S8P304701	
	475	B7 STUD UN8 2-2H 1 1/4 x 475	B7S8P304751	
	485	B7 STUD UN8 2-2H 1 1/4 x 485	B7S8P304851	
	490	B7 STUD UN8 2-2H 1 1/4 x 490	B7S8P304901	
	495	B7 STUD UN8 2-2H 1 1/4 x 495	B7S8P304951	
500	B7 STUD UN8 2-2H 1 1/4 x 500	B7S8P305001		
510	B7 STUD UN8 2-2H 1 1/4 x 510	B7S8P305101		

B7 BREMSTUD

BREMICK

B7 BREMSTUD**Stud Complete with 2 x 2H Nuts**
UN8 PLAIN

ASTM A193/A193M & ASTM A194/A194M

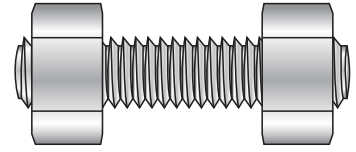

Diameter (inches)	Length (mm)	Description	Product Code	Std. Pack
1.3/8"	75	B7 STUD UN8 2-2H 1 3/8 x 75	B7S8P330751	1
	80	B7 STUD UN8 2-2H 1 3/8 x 80	B7S8P330801	
	90	B7 STUD UN8 2-2H 1 3/8 x 90	B7S8P330901	
	95	B7 STUD UN8 2-2H 1 3/8 x 95	B7S8P330951	
	100	B7 STUD UN8 2-2H 1 3/8 x 100	B7S8P331001	
	110	B7 STUD UN8 2-2H 1 3/8 x 110	B7S8P331101	
	115	B7 STUD UN8 2-2H 1 3/8 x 115	B7S8P331151	
	120	B7 STUD UN8 2-2H 1 3/8 x 120	B7S8P331201	
	125	B7 STUD UN8 2-2H 1 3/8 x 125	B7S8P331251	
	130	B7 STUD UN8 2-2H 1 3/8 x 130	B7S8P331301	
	140	B7 STUD UN8 2-2H 1 3/8 x 140	B7S8P331401	
	145	B7 STUD UN8 2-2H 1 3/8 x 145	B7S8P331451	
	150	B7 STUD UN8 2-2H 1 3/8 x 150	B7S8P331501	
	160	B7 STUD UN8 2-2H 1 3/8 x 160	B7S8P331601	
	165	B7 STUD UN8 2-2H 1 3/8 x 165	B7S8P331651	
	170	B7 STUD UN8 2-2H 1 3/8 x 170	B7S8P331701	
	180	B7 STUD UN8 2-2H 1 3/8 x 180	B7S8P331801	
	185	B7 STUD UN8 2-2H 1 3/8 x 185	B7S8P331851	
	190	B7 STUD UN8 2-2H 1 3/8 x 190	B7S8P331901	
	195	B7 STUD UN8 2-2H 1 3/8 x 195	B7S8P331951	
	200	B7 STUD UN8 2-2H 1 3/8 x 200	B7S8P332001	
	210	B7 STUD UN8 2-2H 1 3/8 x 210	B7S8P332101	
	215	B7 STUD UN8 2-2H 1 3/8 x 215	B7S8P332151	
	220	B7 STUD UN8 2-2H 1 3/8 x 220	B7S8P332201	
	230	B7 STUD UN8 2-2H 1 3/8 x 230	B7S8P332301	
	235	B7 STUD UN8 2-2H 1 3/8 x 235	B7S8P332351	
	240	B7 STUD UN8 2-2H 1 3/8 x 240	B7S8P332401	
	250	B7 STUD UN8 2-2H 1 3/8 x 250	B7S8P332501	
	255	B7 STUD UN8 2-2H 1 3/8 x 255	B7S8P332551	
	260	B7 STUD UN8 2-2H 1 3/8 x 260	B7S8P332601	
	265	B7 STUD UN8 2-2H 1 3/8 x 265	B7S8P332651	
	275	B7 STUD UN8 2-2H 1 3/8 x 275	B7S8P332751	
	280	B7 STUD UN8 2-2H 1 3/8 x 280	B7S8P332801	
285	B7 STUD UN8 2-2H 1 3/8 x 285	B7S8P332851		
290	B7 STUD UN8 2-2H 1 3/8 x 290	B7S8P332901		
300	B7 STUD UN8 2-2H 1 3/8 x 300	B7S8P333001		
305	B7 STUD UN8 2-2H 1 3/8 x 305	B7S8P333051		

CONTINUED OVER PAGE ►

B7 BREMSTUD

BREMSTUDBF
B7

Stud Complete with 2 x 2H Nuts

UN8 PLAIN

ASTM A193/A193M & ASTM A194/A194M

(CONTINUED)

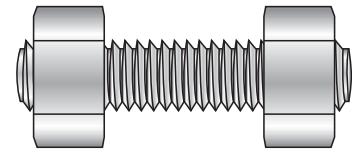

Diameter (inches)	Length (mm)	Description	Product Code	Std. Pack
1.3/8"	310	B7 STUD UN8 2-2H 1 3/8 x 310	B7S8P333101	1
	320	B7 STUD UN8 2-2H 1 3/8 x 320	B7S8P333201	
	325	B7 STUD UN8 2-2H 1 3/8 x 325	B7S8P333251	
	330	B7 STUD UN8 2-2H 1 3/8 x 330	B7S8P333301	
	335	B7 STUD UN8 2-2H 1 3/8 x 335	B7S8P333351	
	345	B7 STUD UN8 2-2H 1 3/8 x 345	B7S8P333451	
	350	B7 STUD UN8 2-2H 1 3/8 x 350	B7S8P333501	
	355	B7 STUD UN8 2-2H 1 3/8 x 355	B7S8P333551	
	360	B7 STUD UN8 2-2H 1 3/8 x 360	B7S8P333601	
	370	B7 STUD UN8 2-2H 1 3/8 x 370	B7S8P333701	
	375	B7 STUD UN8 2-2H 1 3/8 x 375	B7S8P333751	
	380	B7 STUD UN8 2-2H 1 3/8 x 380	B7S8P333801	
	385	B7 STUD UN8 2-2H 1 3/8 x 385	B7S8P333851	
	395	B7 STUD UN8 2-2H 1 3/8 x 395	B7S8P333951	
	400	B7 STUD UN8 2-2H 1 3/8 x 400	B7S8P334001	
	405	B7 STUD UN8 2-2H 1 3/8 x 405	B7S8P334051	
	415	B7 STUD UN8 2-2H 1 3/8 x 415	B7S8P334151	
	420	B7 STUD UN8 2-2H 1 3/8 x 420	B7S8P334201	
	425	B7 STUD UN8 2-2H 1 3/8 x 425	B7S8P334251	
	430	B7 STUD UN8 2-2H 1 3/8 x 430	B7S8P334301	
	440	B7 STUD UN8 2-2H 1 3/8 x 440	B7S8P334401	
	445	B7 STUD UN8 2-2H 1 3/8 x 445	B7S8P334451	
	450	B7 STUD UN8 2-2H 1 3/8 x 450	B7S8P334501	
	455	B7 STUD UN8 2-2H 1 3/8 x 455	B7S8P334551	
	465	B7 STUD UN8 2-2H 1 3/8 x 465	B7S8P334651	
	470	B7 STUD UN8 2-2H 1 3/8 x 470	B7S8P334701	
	475	B7 STUD UN8 2-2H 1 3/8 x 475	B7S8P334751	
	485	B7 STUD UN8 2-2H 1 3/8 x 485	B7S8P334851	
	490	B7 STUD UN8 2-2H 1 3/8 x 490	B7S8P334901	
	495	B7 STUD UN8 2-2H 1 3/8 x 495	B7S8P334951	
500	B7 STUD UN8 2-2H 1 3/8 x 500	B7S8P335001		
510	B7 STUD UN8 2-2H 1 3/8 x 510	B7S8P335101		

B7 BREMSTUD

BREMICK

B7 BREMSTUD**Stud Complete with 2 x 2H Nuts**
UN8 PLAIN

ASTM A193/A193M & ASTM A194/A194M

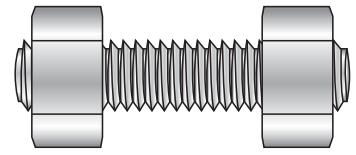

Diameter (inches)	Length (mm)	Description	Product Code	Std. Pack
1.1/2"	110	B7 STUD UN8 2-2H 1 1/2 x 110	B7S8P361101	2
	115	B7 STUD UN8 2-2H 1 1/2 x 115	B7S8P361151	
	120	B7 STUD UN8 2-2H 1 1/2 x 120	B7S8P361201	
	125	B7 STUD UN8 2-2H 1 1/2 x 125	B7S8P361251	
	130	B7 STUD UN8 2-2H 1 1/2 x 130	B7S8P361301	
	140	B7 STUD UN8 2-2H 1 1/2 x 140	B7S8P361401	
	145	B7 STUD UN8 2-2H 1 1/2 x 145	B7S8P361451	
	150	B7 STUD UN8 2-2H 1 1/2 x 150	B7S8P361501	
	160	B7 STUD UN8 2-2H 1 1/2 x 160	B7S8P361601	
	165	B7 STUD UN8 2-2H 1 1/2 x 165	B7S8P361651	
	170	B7 STUD UN8 2-2H 1 1/2 x 170	B7S8P361701	
	180	B7 STUD UN8 2-2H 1 1/2 x 180	B7S8P361801	
	185	B7 STUD UN8 2-2H 1 1/2 x 185	B7S8P361851	
	190	B7 STUD UN8 2-2H 1 1/2 x 190	B7S8P361901	
	195	B7 STUD UN8 2-2H 1 1/2 x 195	B7S8P361951	
	200	B7 STUD UN8 2-2H 1 1/2 x 200	B7S8P362001	
	210	B7 STUD UN8 2-2H 1 1/2 x 210	B7S8P362101	
	215	B7 STUD UN8 2-2H 1 1/2 x 215	B7S8P362151	
	220	B7 STUD UN8 2-2H 1 1/2 x 220	B7S8P362201	
	230	B7 STUD UN8 2-2H 1 1/2 x 230	B7S8P362301	
	235	B7 STUD UN8 2-2H 1 1/2 x 235	B7S8P362351	
	240	B7 STUD UN8 2-2H 1 1/2 x 240	B7S8P362401	
	250	B7 STUD UN8 2-2H 1 1/2 x 250	B7S8P362501	
	255	B7 STUD UN8 2-2H 1 1/2 x 255	B7S8P362551	
	260	B7 STUD UN8 2-2H 1 1/2 x 260	B7S8P362601	
	265	B7 STUD UN8 2-2H 1 1/2 x 265	B7S8P362651	
	275	B7 STUD UN8 2-2H 1 1/2 x 275	B7S8P362751	
	280	B7 STUD UN8 2-2H 1 1/2 x 280	B7S8P362801	
	285	B7 STUD UN8 2-2H 1 1/2 x 285	B7S8P362851	
	290	B7 STUD UN8 2-2H 1 1/2 x 290	B7S8P362901	
	300	B7 STUD UN8 2-2H 1 1/2 x 300	B7S8P363001	
	305	B7 STUD UN8 2-2H 1 1/2 x 305	B7S8P363051	1
	310	B7 STUD UN8 2-2H 1 1/2 x 310	B7S8P363101	
320	B7 STUD UN8 2-2H 1 1/2 x 320	B7S8P363201		
325	B7 STUD UN8 2-2H 1 1/2 x 325	B7S8P363251		
330	B7 STUD UN8 2-2H 1 1/2 x 330	B7S8P363301		
335	B7 STUD UN8 2-2H 1 1/2 x 335	B7S8P363351		

CONTINUED OVER PAGE ►

B7 BREMSTUD



BF
B7

Stud Complete with 2 x 2H Nuts
UN8 PLAIN

ASTM A193/A193M & ASTM A194/A194M

(CONTINUED)

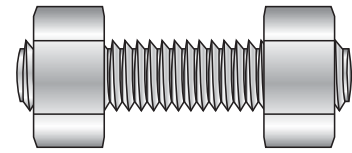

Diameter (inches)	Length (mm)	Description	Product Code	Std. Pack
1.1/2"	345	B7 STUD UN8 2-2H 1 1/2 x 345	B7S8P363451	1
	350	B7 STUD UN8 2-2H 1 1/2 x 350	B7S8P363501	
	355	B7 STUD UN8 2-2H 1 1/2 x 355	B7S8P363551	
	360	B7 STUD UN8 2-2H 1 1/2 x 360	B7S8P363601	
	370	B7 STUD UN8 2-2H 1 1/2 x 370	B7S8P363701	
	375	B7 STUD UN8 2-2H 1 1/2 x 375	B7S8P363751	
	380	B7 STUD UN8 2-2H 1 1/2 x 380	B7S8P363801	
	385	B7 STUD UN8 2-2H 1 1/2 x 385	B7S8P363851	
	395	B7 STUD UN8 2-2H 1 1/2 x 395	B7S8P363951	
	400	B7 STUD UN8 2-2H 1 1/2 x 400	B7S8P364001	
	405	B7 STUD UN8 2-2H 1 1/2 x 405	B7S8P364051	
	415	B7 STUD UN8 2-2H 1 1/2 x 415	B7S8P364151	
	420	B7 STUD UN8 2-2H 1 1/2 x 420	B7S8P364201	
	425	B7 STUD UN8 2-2H 1 1/2 x 425	B7S8P364251	
	430	B7 STUD UN8 2-2H 1 1/2 x 430	B7S8P364301	
	440	B7 STUD UN8 2-2H 1 1/2 x 440	B7S8P364401	
	445	B7 STUD UN8 2-2H 1 1/2 x 445	B7S8P364451	
	450	B7 STUD UN8 2-2H 1 1/2 x 450	B7S8P364501	
	455	B7 STUD UN8 2-2H 1 1/2 x 455	B7S8P364551	
	465	B7 STUD UN8 2-2H 1 1/2 x 465	B7S8P364651	
	470	B7 STUD UN8 2-2H 1 1/2 x 470	B7S8P364701	
	475	B7 STUD UN8 2-2H 1 1/2 x 475	B7S8P364751	
	485	B7 STUD UN8 2-2H 1 1/2 x 485	B7S8P364851	
	490	B7 STUD UN8 2-2H 1 1/2 x 490	B7S8P364901	
	495	B7 STUD UN8 2-2H 1 1/2 x 495	B7S8P364951	
	500	B7 STUD UN8 2-2H 1 1/2 x 500	B7S8P365001	
	510	B7 STUD UN8 2-2H 1 1/2 x 510	B7S8P365101	

B7 BREMSTUD

BREMICK

B7 BREMSTUD**Stud Complete with 2 x 2H Nuts**
UN8 PLAIN

ASTM A193/A193M & ASTM A194/A194M

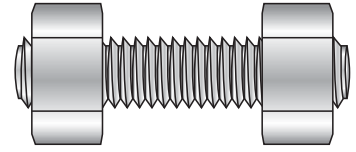

Diameter (inches)	Length (mm)	Description	Product Code	Std. Pack
1.5/8"	150	B7 STUD UN8 2-2H 1 5/8 x 150	B7S8P391501	1
	160	B7 STUD UN8 2-2H 1 5/8 x 160	B7S8P391601	
	165	B7 STUD UN8 2-2H 1 5/8 x 165	B7S8P391651	
	170	B7 STUD UN8 2-2H 1 5/8 x 170	B7S8P391701	
	180	B7 STUD UN8 2-2H 1 5/8 x 180	B7S8P391801	
	185	B7 STUD UN8 2-2H 1 5/8 x 185	B7S8P391851	
	190	B7 STUD UN8 2-2H 1 5/8 x 190	B7S8P391901	
	195	B7 STUD UN8 2-2H 1 5/8 x 195	B7S8P391951	
	200	B7 STUD UN8 2-2H 1 5/8 x 200	B7S8P392001	
	210	B7 STUD UN8 2-2H 1 5/8 x 210	B7S8P392101	
	215	B7 STUD UN8 2-2H 1 5/8 x 215	B7S8P392151	
	220	B7 STUD UN8 2-2H 1 5/8 x 220	B7S8P392201	
	230	B7 STUD UN8 2-2H 1 5/8 x 230	B7S8P392301	
	235	B7 STUD UN8 2-2H 1 5/8 x 235	B7S8P392351	
	240	B7 STUD UN8 2-2H 1 5/8 x 240	B7S8P392401	
	250	B7 STUD UN8 2-2H 1 5/8 x 250	B7S8P392501	
	255	B7 STUD UN8 2-2H 1 5/8 x 255	B7S8P392551	
	260	B7 STUD UN8 2-2H 1 5/8 x 260	B7S8P392601	
	265	B7 STUD UN8 2-2H 1 5/8 x 265	B7S8P392651	
	275	B7 STUD UN8 2-2H 1 5/8 x 275	B7S8P392751	
	280	B7 STUD UN8 2-2H 1 5/8 x 280	B7S8P392801	
	285	B7 STUD UN8 2-2H 1 5/8 x 285	B7S8P392851	
	290	B7 STUD UN8 2-2H 1 5/8 x 290	B7S8P392901	
	300	B7 STUD UN8 2-2H 1 5/8 x 300	B7S8P393001	
	305	B7 STUD UN8 2-2H 1 5/8 x 305	B7S8P393051	
	310	B7 STUD UN8 2-2H 1 5/8 x 310	B7S8P393101	
	320	B7 STUD UN8 2-2H 1 5/8 x 320	B7S8P393201	
	325	B7 STUD UN8 2-2H 1 5/8 x 325	B7S8P393251	
	330	B7 STUD UN8 2-2H 1 5/8 x 330	B7S8P393301	
	335	B7 STUD UN8 2-2H 1 5/8 x 335	B7S8P393351	
	345	B7 STUD UN8 2-2H 1 5/8 x 345	B7S8P393451	
	350	B7 STUD UN8 2-2H 1 5/8 x 350	B7S8P393501	
	355	B7 STUD UN8 2-2H 1 5/8 x 355	B7S8P393551	
	360	B7 STUD UN8 2-2H 1 5/8 x 360	B7S8P393601	
	370	B7 STUD UN8 2-2H 1 5/8 x 370	B7S8P393701	
	375	B7 STUD UN8 2-2H 1 5/8 x 375	B7S8P393751	
	380	B7 STUD UN8 2-2H 1 5/8 x 380	B7S8P393801	

CONTINUED OVER PAGE ►

B7 BREMSTUD

BREMSTUDBF
B7

Stud Complete with 2 x 2H Nuts
UN8 PLAIN
ASTM A193/A193M & ASTM A194/A194M
(CONTINUED)

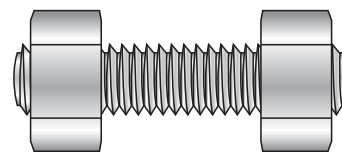

Diameter (inches)	Length (mm)	Description	Product Code	Std. Pack
1.5/8"	385	B7 STUD UN8 2-2H 1 5/8 x 385	B7S8P393851	1
	395	B7 STUD UN8 2-2H 1 5/8 x 395	B7S8P393951	
	400	B7 STUD UN8 2-2H 1 5/8 x 400	B7S8P394001	
	405	B7 STUD UN8 2-2H 1 5/8 x 405	B7S8P394051	
	415	B7 STUD UN8 2-2H 1 5/8 x 415	B7S8P394151	
	420	B7 STUD UN8 2-2H 1 5/8 x 420	B7S8P394201	
	425	B7 STUD UN8 2-2H 1 5/8 x 425	B7S8P394251	
	430	B7 STUD UN8 2-2H 1 5/8 x 430	B7S8P394301	
	440	B7 STUD UN8 2-2H 1 5/8 x 440	B7S8P394401	
	445	B7 STUD UN8 2-2H 1 5/8 x 445	B7S8P394451	
	450	B7 STUD UN8 2-2H 1 5/8 x 450	B7S8P394501	
	455	B7 STUD UN8 2-2H 1 5/8 x 455	B7S8P394551	
	465	B7 STUD UN8 2-2H 1 5/8 x 465	B7S8P394651	
	470	B7 STUD UN8 2-2H 1 5/8 x 470	B7S8P394701	
	475	B7 STUD UN8 2-2H 1 5/8 x 475	B7S8P394751	
	485	B7 STUD UN8 2-2H 1 5/8 x 485	B7S8P394851	
	490	B7 STUD UN8 2-2H 1 5/8 x 490	B7S8P394901	
	495	B7 STUD UN8 2-2H 1 5/8 x 495	B7S8P394951	
	500	B7 STUD UN8 2-2H 1 5/8 x 500	B7S8P395001	
	510	B7 STUD UN8 2-2H 1 5/8 x 510	B7S8P395101	

B7 BREMSTUD

BREMICK

B7 BREMSTUD**Stud Complete with 2 x 2H Nuts**
UN8 PLAIN

ASTM A193/A193M & ASTM A194/A194M

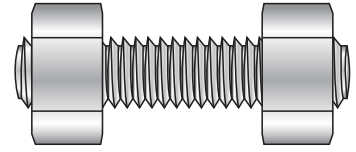

Diameter (inches)	Length (mm)	Description	Product Code	Std. Pack
1.3/4"	150	B7 STUD UN8 2-2H 1 3/4 x 150	B7S8P421501	1
	160	B7 STUD UN8 2-2H 1 3/4 x 160	B7S8P421601	
	165	B7 STUD UN8 2-2H 1 3/4 x 165	B7S8P421651	
	170	B7 STUD UN8 2-2H 1 3/4 x 170	B7S8P421701	
	180	B7 STUD UN8 2-2H 1 3/4 x 180	B7S8P421801	
	185	B7 STUD UN8 2-2H 1 3/4 x 185	B7S8P421851	
	190	B7 STUD UN8 2-2H 1 3/4 x 190	B7S8P421901	
	195	B7 STUD UN8 2-2H 1 3/4 x 195	B7S8P421951	
	200	B7 STUD UN8 2-2H 1 3/4 x 200	B7S8P422001	
	210	B7 STUD UN8 2-2H 1 3/4 x 210	B7S8P422101	
	215	B7 STUD UN8 2-2H 1 3/4 x 215	B7S8P422151	
	220	B7 STUD UN8 2-2H 1 3/4 x 220	B7S8P422201	
	230	B7 STUD UN8 2-2H 1 3/4 x 230	B7S8P422301	
	235	B7 STUD UN8 2-2H 1 3/4 x 235	B7S8P422351	
	240	B7 STUD UN8 2-2H 1 3/4 x 240	B7S8P422401	
	250	B7 STUD UN8 2-2H 1 3/4 x 250	B7S8P422501	
	255	B7 STUD UN8 2-2H 1 3/4 x 255	B7S8P422551	
	260	B7 STUD UN8 2-2H 1 3/4 x 260	B7S8P422601	
	265	B7 STUD UN8 2-2H 1 3/4 x 265	B7S8P422651	
	275	B7 STUD UN8 2-2H 1 3/4 x 275	B7S8P422751	
	280	B7 STUD UN8 2-2H 1 3/4 x 280	B7S8P422801	
	285	B7 STUD UN8 2-2H 1 3/4 x 285	B7S8P422851	
	290	B7 STUD UN8 2-2H 1 3/4 x 290	B7S8P422901	
	300	B7 STUD UN8 2-2H 1 3/4 x 300	B7S8P423001	
	305	B7 STUD UN8 2-2H 1 3/4 x 305	B7S8P423051	
	310	B7 STUD UN8 2-2H 1 3/4 x 310	B7S8P423101	
	320	B7 STUD UN8 2-2H 1 3/4 x 320	B7S8P423201	
	325	B7 STUD UN8 2-2H 1 3/4 x 325	B7S8P423251	
	330	B7 STUD UN8 2-2H 1 3/4 x 330	B7S8P423301	
	335	B7 STUD UN8 2-2H 1 3/4 x 335	B7S8P423351	
	345	B7 STUD UN8 2-2H 1 3/4 x 345	B7S8P423451	
	350	B7 STUD UN8 2-2H 1 3/4 x 350	B7S8P423501	
	355	B7 STUD UN8 2-2H 1 3/4 x 355	B7S8P423551	
	360	B7 STUD UN8 2-2H 1 3/4 x 360	B7S8P423601	
	370	B7 STUD UN8 2-2H 1 3/4 x 370	B7S8P423701	
	375	B7 STUD UN8 2-2H 1 3/4 x 375	B7S8P423751	
	380	B7 STUD UN8 2-2H 1 3/4 x 380	B7S8P423801	

CONTINUED OVER PAGE ►

B7 BREMSTUD



BF
B7

Stud Complete with 2 x 2H Nuts

UN8 PLAIN

ASTM A193/A193M & ASTM A194/A194M

(CONTINUED)

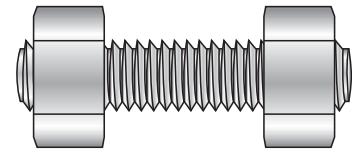

Diameter (inches)	Length (mm)	Description	Product Code	Std. Pack
1.3/4"	385	B7 STUD UN8 2-2H 1 3/4 x 385	B7S8P423851	1
	395	B7 STUD UN8 2-2H 1 3/4 x 395	B7S8P423951	
	400	B7 STUD UN8 2-2H 1 3/4 x 400	B7S8P424001	
	405	B7 STUD UN8 2-2H 1 3/4 x 405	B7S8P424051	
	415	B7 STUD UN8 2-2H 1 3/4 x 415	B7S8P424151	
	420	B7 STUD UN8 2-2H 1 3/4 x 420	B7S8P424201	
	425	B7 STUD UN8 2-2H 1 3/4 x 425	B7S8P424251	
	430	B7 STUD UN8 2-2H 1 3/4 x 430	B7S8P424301	
	440	B7 STUD UN8 2-2H 1 3/4 x 440	B7S8P424401	
	445	B7 STUD UN8 2-2H 1 3/4 x 445	B7S8P424451	
	450	B7 STUD UN8 2-2H 1 3/4 x 450	B7S8P424501	
	455	B7 STUD UN8 2-2H 1 3/4 x 455	B7S8P424551	
	465	B7 STUD UN8 2-2H 1 3/4 x 465	B7S8P424651	
	470	B7 STUD UN8 2-2H 1 3/4 x 470	B7S8P424701	
	475	B7 STUD UN8 2-2H 1 3/4 x 475	B7S8P424751	
	485	B7 STUD UN8 2-2H 1 3/4 x 485	B7S8P424851	
	490	B7 STUD UN8 2-2H 1 3/4 x 490	B7S8P424901	
	495	B7 STUD UN8 2-2H 1 3/4 x 495	B7S8P424951	
	500	B7 STUD UN8 2-2H 1 3/4 x 500	B7S8P425001	
	510	B7 STUD UN8 2-2H 1 3/4 x 510	B7S8P425101	

B7 BREMSTUD

BREMICK

B7 BREMSTUD

Stud Complete with 2 x 2H Nuts
UN8 PLAIN

ASTM A193/A193M & ASTM A194/A194M

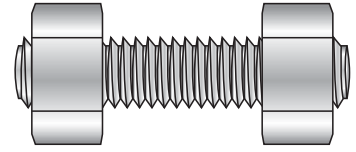

Diameter (inches)	Length (mm)	Description	Product Code	Std. Pack
1.7/8"	355	B7 STUD UN8 2-2H 1 7/8 x 355	B7S8P453551	1
	360	B7 STUD UN8 2-2H 1 7/8 x 360	B7S8P453601	
	370	B7 STUD UN8 2-2H 1 7/8 x 370	B7S8P453701	
	375	B7 STUD UN8 2-2H 1 7/8 x 375	B7S8P453751	
	380	B7 STUD UN8 2-2H 1 7/8 x 380	B7S8P453801	
	385	B7 STUD UN8 2-2H 1 7/8 x 385	B7S8P453851	
	395	B7 STUD UN8 2-2H 1 7/8 x 395	B7S8P453951	
	400	B7 STUD UN8 2-2H 1 7/8 x 400	B7S8P454001	
	405	B7 STUD UN8 2-2H 1 7/8 x 405	B7S8P454051	
	415	B7 STUD UN8 2-2H 1 7/8 x 415	B7S8P454151	
	420	B7 STUD UN8 2-2H 1 7/8 x 420	B7S8P454201	
	425	B7 STUD UN8 2-2H 1 7/8 x 425	B7S8P454251	
	430	B7 STUD UN8 2-2H 1 7/8 x 430	B7S8P454301	
	440	B7 STUD UN8 2-2H 1 7/8 x 440	B7S8P454401	
	445	B7 STUD UN8 2-2H 1 7/8 x 445	B7S8P454451	
	450	B7 STUD UN8 2-2H 1 7/8 x 450	B7S8P454501	
	455	B7 STUD UN8 2-2H 1 7/8 x 455	B7S8P454551	
	465	B7 STUD UN8 2-2H 1 7/8 x 465	B7S8P454651	
	470	B7 STUD UN8 2-2H 1 7/8 x 470	B7S8P454701	
	475	B7 STUD UN8 2-2H 1 7/8 x 475	B7S8P454751	
	485	B7 STUD UN8 2-2H 1 7/8 x 485	B7S8P454851	
	490	B7 STUD UN8 2-2H 1 7/8 x 490	B7S8P454901	
	495	B7 STUD UN8 2-2H 1 7/8 x 495	B7S8P454951	
	500	B7 STUD UN8 2-2H 1 7/8 x 500	B7S8P455001	
	510	B7 STUD UN8 2-2H 1 7/8 x 510	B7S8P455101	

B7 BREMSTUD

BREMSTUDBF
B7

Stud Complete with 2 x 2H Nuts
UN8 PLAIN
ASTM A193/A193M & ASTM A194/A194M

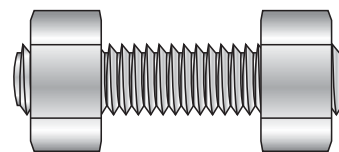

Diameter (inches)	Length (mm)	Description	Product Code	Std. Pack
2"	355	B7 STUD UN8 2-2H 2 x 355	B7S8P483551	1
	360	B7 STUD UN8 2-2H 2 x 360	B7S8P483601	
	370	B7 STUD UN8 2-2H 2 x 370	B7S8P483701	
	375	B7 STUD UN8 2-2H 2 x 375	B7S8P483751	
	380	B7 STUD UN8 2-2H 2 x 380	B7S8P483801	
	385	B7 STUD UN8 2-2H 2 x 385	B7S8P483851	
	395	B7 STUD UN8 2-2H 2 x 395	B7S8P483951	
	400	B7 STUD UN8 2-2H 2 x 400	B7S8P484001	
	405	B7 STUD UN8 2-2H 2 x 405	B7S8P484051	
	415	B7 STUD UN8 2-2H 2 x 415	B7S8P484151	
	420	B7 STUD UN8 2-2H 2 x 420	B7S8P484201	
	425	B7 STUD UN8 2-2H 2 x 425	B7S8P484251	
	430	B7 STUD UN8 2-2H 2 x 430	B7S8P484301	
	440	B7 STUD UN8 2-2H 2 x 440	B7S8P484401	
	445	B7 STUD UN8 2-2H 2 x 445	B7S8P484451	
	450	B7 STUD UN8 2-2H 2 x 450	B7S8P484501	
	455	B7 STUD UN8 2-2H 2 x 455	B7S8P484551	
	465	B7 STUD UN8 2-2H 2 x 465	B7S8P484651	
	470	B7 STUD UN8 2-2H 2 x 470	B7S8P484701	
	475	B7 STUD UN8 2-2H 2 x 475	B7S8P484751	
	485	B7 STUD UN8 2-2H 2 x 485	B7S8P484851	
	490	B7 STUD UN8 2-2H 2 x 490	B7S8P484901	
	495	B7 STUD UN8 2-2H 2 x 495	B7S8P484951	
	500	B7 STUD UN8 2-2H 2 x 500	B7S8P485001	
	510	B7 STUD UN8 2-2H 2 x 510	B7S8P485101	

B7 BREMSTUD

BREMICK

HEAVY SERIES HEX NUTS



Grade 2H
UNC / UN8 PLAIN
ASTM A194/A194M

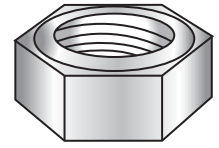

Diameter (inches)	TPI	Description	Product Code	Std. Pack
3/8"	16	G2H HEAVY HEX NUTS PLN UNC 3/8	N2HCP100002	200
1/2"	13	G2H HEAVY HEX NUTS PLN UNC 1/2	N2HCP120002	150
5/8"	11	G2H HEAVY HEX NUTS PLN UNC 5/8	N2HCP160002	75
3/4"	10	G2H HEAVY HEX NUTS PLN UNC 3/4	N2HCP200002	
7/8"	9	G2H HEAVY HEX NUTS PLN UNC 7/8	N2HCP220002	50
1"	8	G2H HEAVY HEX NUTS PLN UNC 1	N2HCP240002	
1.1/8"	8	G2H HEAVY HEX NUTS PLN UN8 1 1/8	N2H8P270002	25
1.1/4"	8	G2H HEAVY HEX NUTS PLN UN8 1 1/4	N2H8P300002	
1.3/8"	8	G2H HEAVY HEX NUTS PLN UN8 1 3/8	N2H8P330002	15
1.1/2"	8	G2H HEAVY HEX NUTS PLN UN8 1 1/2	N2H8P360002	
1.5/8"	8	G2H HEAVY HEX NUTS PLN UN8 1 5/8	N2H8P390002	1
1.3/4"	8	G2H HEAVY HEX NUTS PLN UN8 1 3/4	N2H8P420002	
1.7/8"	8	G2H HEAVY HEX NUTS PLN UN8 1 7/8	N2H8P450002	
2"	8	G2H HEAVY HEX NUTS PLN UN8 2	N2H8P480002	
2.1/4"	8	G2H HEAVY HEX NUTS PLN UN8 2 1/4	N2H8P560002	
2.1/2"	8	G2H HEAVY HEX NUTS PLN UN8 2 1/2	N2H8P600002	
2.3/4"	8	G2H HEAVY HEX NUTS PLN UN8 2 3/4	N2H8P640002	
3"	8	G2H HEAVY HEX NUTS PLN UN8 3	N2H8P720002	
3.1/2"	8	G2H HEAVY HEX NUTS PLN UN8 3 1/2	N2H8P840002	

HEAVY SERIES HEX NUTS



BF
B7

Grade 7
UNC / UN8 PLAIN
ASTM A194/A194M

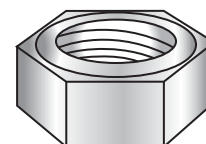

Diameter (inches)	TPI	Description	Product Code	Std. Pack
3/8"	16	G7 HEAVY HEX NUTS PLN UNC 3/8	N7HCP100002	100
1/2"	13	G7 HEAVY HEX NUTS PLN UNC 1/2	N7HCP120002	
5/8"	11	G7 HEAVY HEX NUTS PLN UNC 5/8	N7HCP160002	50
3/4"	10	G7 HEAVY HEX NUTS PLN UNC 3/4	N7HCP200002	
7/8"	9	G7 HEAVY HEX NUTS PLN UNC 7/8	N7HCP220002	25
1"	8	G7 HEAVY HEX NUTS PLN UNC 1	N7HCP240002	
1.1/8"	8	G7 HEAVY HEX NUTS PLN UN8 1 1/8	N7H8P270002	15
1.1/4"	8	G7 HEAVY HEX NUTS PLN UN8 1 1/4	N7H8P300002	10
1.3/8"	8	G7 HEAVY HEX NUTS PLN UN8 1 3/8	N7H8P330002	5
1.1/2"	8	G7 HEAVY HEX NUTS PLN UN8 1 1/2	N7H8P360002	
1.5/8"	8	G7 HEAVY HEX NUTS PLN UN8 1 5/8	N7H8P390002	1
1.3/4"	8	G7 HEAVY HEX NUTS PLN UN8 1 3/4	N7H8P420002	
1.7/8"	8	G7 HEAVY HEX NUTS PLN UN8 1 7/8	N7H8P450002	
2"	8	G7 HEAVY HEX NUTS PLN UN8 2	N7H8P480002	
2.1/4"	8	G7 HEAVY HEX NUTS PLN UN8 2 1/4	N7H8P560002	
2.1/2"	8	G7 HEAVY HEX NUTS PLN UN8 2 1/2	N7H8P600002	
2.3/4"	8	G7 HEAVY HEX NUTS PLN UN8 2 3/4	N7H8P640002	
3"	8	G7 HEAVY HEX NUTS PLN UN8 3	N7H8P720002	

HEAVY SERIES HEX NUTS

BREMICK

HEAVY SERIES HEX NUTS

BREMICK

Grade 4
UNC / UN8 PLAIN
ASTM A194/A194M

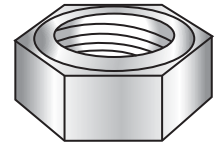

Diameter (inches)	TPI	Description	Product Code	Std. Pack
1/2"	13	G4 HEAVY HEX NUTS PLN UNC 1/2	N4HCP120002	100
5/8"	11	G4 HEAVY HEX NUTS PLN UNC 5/8	N4HCP160002	50
3/4"	10	G4 HEAVY HEX NUTS PLN UNC 3/4	N4HCP200002	50
7/8"	9	G4 HEAVY HEX NUTS PLN UNC 7/8	N4HCP220002	25
1"	8	G4 HEAVY HEX NUTS PLN UNC 1"	N4HCP240002	25
1.1/8"	8	G4 HEAVY HEX NUTS PLN UN8 1 1/8	N4H8P270002	15
1.1/4"	8	G4 HEAVY HEX NUTS PLN UN8 1 1/4	N4H8P300002	10
1.3/8"	8	G4 HEAVY HEX NUTS PLN UN8 1 3/8	N4H8P330002	5
1.1/2"	8	G4 HEAVY HEX NUTS PLN UN8 1 1/2	N4H8P360002	5
1.5/8"	8	G4 HEAVY HEX NUTS PLN UN8 1 5/8	N4H8P390002	1
1.3/4"	8	G4 HEAVY HEX NUTS PLN UN8 1 3/4	N4H8P420002	
1.7/8"	8	G4 HEAVY HEX NUTS PLN UN8 1 7/8	N4H8P450002	
2"	8	G4 HEAVY HEX NUTS PLN UN8 2"	N4H8P480002	

HEAVY SERIES HEX NUTS

BREMICK

Grade 8 (SS304)
UNC / UN8
ASTM A194/A194M

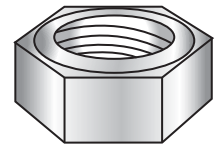

Diameter (inches)	TPI	Description	Product Code	Std. Pack
3/8"	16	G8 HEAVY HEX NUTS 304 UNC 3/8	N8HC4100002	100
1/2"	13	G8 HEAVY HEX NUTS 304 UNC 1/2	N8HC4120002	
5/8"	11	G8 HEAVY HEX NUTS 304 UNC 5/8	N8HC4160002	50
3/4"	10	G8 HEAVY HEX NUTS 304 UNC 3/4	N8HC4200002	
7/8"	9	G8 HEAVY HEX NUTS 304 UNC 7/8	N8HC4220002	25
1"	8	G8 HEAVY HEX NUTS 304 UNC 1	N8HC4240002	
1.1/8"	8	G8 HEAVY HEX NUTS 304 UN8 1 1/8	N8H84270002	15
1.1/4"	8	G8 HEAVY HEX NUTS 304 UN8 1 1/4	N8H84300002	10
1.3/8"	8	G8 HEAVY HEX NUTS 304 UN8 1 3/8	N8H84330002	5
1.1/2"	8	G8 HEAVY HEX NUTS 304 UN8 1 1/2	N8H84360002	

HEAVY SERIES HEX NUTS



BF
B7

Grade 8M (SS316)
UNC / UN8
ASTM A194/A194M

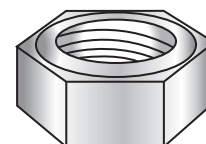

Diameter (inches)	TPI	Description	Product Code	Std. Pack
3/8"	16	G8M HEAVY HEX NUTS 316 UNC 3/8	N8MC6100002	100
1/2"	13	G8M HEAVY HEX NUTS 316 UNC 1/2	N8MC6120002	
5/8"	11	G8M HEAVY HEX NUTS 316 UNC 5/8	N8MC6160002	50
3/4"	10	G8M HEAVY HEX NUTS 316 UNC 3/4	N8MC6200002	
7/8"	9	G8M HEAVY HEX NUTS 316 UNC 7/8	N8MC6220002	25
1"	8	G8M HEAVY HEX NUTS 316 UNC 1	N8MC6240002	
1.1/8"	8	G8M HEAVY HEX NUTS 316 UN8 1 1/8	N8M86270002	15
1.1/4"	8	G8M HEAVY HEX NUTS 316 UN8 1 1/4	N8M86300002	10
1.3/8"	8	G8M HEAVY HEX NUTS 316 UN8 1 3/8	N8M86330002	5
1.1/2"	8	G8M HEAVY HEX NUTS 316 UN8 1 1/2	N8M86360002	
1.5/8"	8	G8M HEAVY HEX NUTS 316 UN8 1 5/8	N8M86390002	1
1.3/4"	8	G8M HEAVY HEX NUTS 316 UN8 1 3/4	N8M86420002	
1.7/8"	8	G8M HEAVY HEX NUTS 316 UN8 1 7/8	N8M86450002	
2"	8	G8M HEAVY HEX NUTS 316 UN8 2"	N8M86480002	
2.1/4"	8	G8M HEAVY HEX NUTS 316 UN8 2 1/4	N8M86560002	

HEAVY SERIES HEX NUTS

BREMICK

Coatings

Fasteners that are employed in petrochemical installations are exposed to the full spectrum of corrosive environments that may include, extreme temperature ranges, long "wetness times", severe industrial environments and severe marine environments.

Bremick manufactures Stud Bolting product, at short lead times, to any customer specified corrosion protection coating or specified lubricating coating. In addition Bremick can provide customers with a unique range of Bremkote composite coatings, that give both optimum protection and controlled lubricity. Each of which is independently performance rated by accelerated testing or long term exposure testing.

Specified Corrosion Protection Coatings

To meet customer specifications Bremick provides petrochemical stud bolts in a wide range of inherently corrosion resistant materials and for other materials that require supplementary corrosion protection we also offer a full range of organic and inorganic coatings to meet any identified coating specification.

Specified Coatings for Lubricity

Where low levels of lubricity are important the Bremick "Bremstud" range of Stud Bolts, Heavy Hex Bolts and Nuts are also available with low friction, organic coatings to meet any customer specification.

Bremkote Coatings

For applications where high levels of corrosion protection and low lubricity is required Bremick has developed a range of proprietary composite coating systems each of which is performance rated to match specific ISO 9223 environmental exposure categories and accelerated exposure in laboratory testing.

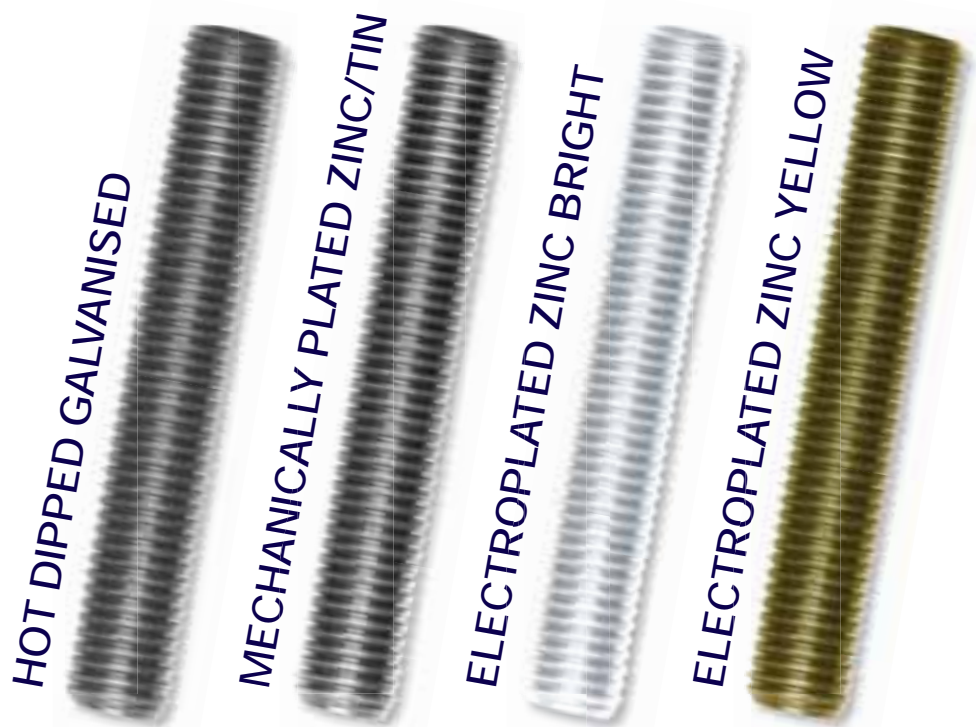

Hot Dipped Galvanized

Coating Type: Inorganic

Coating Description

Most commonly applied coating to B7 Studs is Hot dipped Galvanized. This has a dull silver grey appearance consisting of a nominal coating thickness of 52 micron meters of zinc plating conforming to AS 1214. Hot Dipped Galvanized coating offers a high degree of corrosion protection in corrosive environments up to and including environmental category C5 as classified by ISO 9223.

Features & Benefits

- High level of corrosion resistance
- Long service life due to thicker coatings
- Commonly used and proven in application
- Good compatibility with carbon steels.
- Can be applied to most metals
- Proven

Typical Uses

Application to B7 Studs and over sized nuts for exposure in industrial or marine environments ISO Categories C1 - C5

Coating Properties

Colour	Silver/grey
Finish / appearance	Dull metallic
Torquing coefficient	Unlubricated 0.25
Service Temperature	Up to 210°C
Salt Spray Resistance	Good (up to 5000hrs)
Chemical Resistance	
Solvent Resistance	Good
Acid Resistance	Poor
Alkali Resistance	Good
Conformance Details	AS 1214
Thickness	52µm (average)

Limitations

- High friction coefficient.
- Requires lubrication during tightening
- Uneven plating distribution.
- Thread adjustment required to permit assembly



Mechanically Plated Zinc/Tin

Coating Type: Inorganic

Coating Description

This coating provides a high degree of corrosion protection and is often referred to as Mechanical Galvanizing. The coating is applied by a mechanical deposition process where a metallic coating is applied by impacting particles of the plating metals against the plated parts and cold welding a coating to their surface. This process is ideally suited to threaded components as it imparts an even and controlled coating depth across complex profiles. It also has the advantage of being applied at ambient temperatures and as such does not affect the metallurgy of temperature sensitive alloys or introduce hydrogen embrittlement.

Features & Benefits

- High level of corrosion resistance
- Even plating distribution across threaded parts
- Long service life with thicker coatings
- Commonly used and proven in application
- Good compatibility with carbon steels.
- Does not affect heat sensitive alloys
- No risk of hydrogen embrittlement

Typical Uses

Application to Carbon Steel stud bolts in moderate to highly corrosive industrial and marine environments up to environmental categories C4 as classified by ISO 9223

Coating Properties

Colour:	Silver/grey
Finish / appearance	Dull & smooth
Torquing coefficient	Unlubricated 0.22
Service Temperature	Up to 180°C
Salt Spray Resistance	Good (up to 5000hrs)
Chemical Resistance	
Solvent Resistance	Good
Acid Resistance	Poor
Alkali Resistance	Good
Conformance Details	AS 5056
Thickness	12 to 52µm

Limitations

- High friction coefficient.
- Requires lubrication during tightening
- May require thread adjustment for thicker coatings



Electroplated Zinc - Bright (Clear) & Zinc - Yellow

Coating Type: Inorganic

Coating Description

This coating offers low to medium corrosion protection with a thin zinc coating applied by immersing in water based solution containing a zinc compound that is deposited onto the surface of the metal. For bright / clear electroplating the plated metal is then given an additional clear chromate chemical conversion coating (for zinc yellow a yellow chromate conversion coating is applied) to enhance corrosion protection, colour and paint adhesion. Generally applied in coating thicknesses of 12 to 25 micron metres, where the thinner coatings offer low corrosion protection for application in sheltered environments, where as the thicker coatings are capable of moderate protection up to environmental category C3 as classified by ISO 9223.

Features & Benefits

- Low to moderate levels of corrosion resistance
- Even plating distribution across threads
- Commonly used and proven in application
- Low friction coefficient

Typical Uses

Coating Properties

Colour	Silver/white
Finish / appearance	Bright metallic
Torquing coefficient	Unlubricated 0.24
Service Temperature	up to 210°C
Salt Spray Resistance	Moderate (up to 2000hrs)
Chemical Resistance	
Solvent Resistance	Good
Acid Resistance	Poor
Alkali Resistance	Good
Conformance Details	AS 1789
Thickness	12 to 25µm (nominal)

Limitations

- Low to moderate corrosion protection
- Service life limited by thin coating thickness
- Requires lubrication during tightening



Electroplated Cadmium

Coating Type: Inorganic

Coating Description

This coating offers moderate corrosion protection with a thin cadmium coating applied by immersing in water based solution containing a zinc compound that is deposited onto the surface of the metal and is generally applied in coating thicknesses of 12 micron metres. Cadmium offers higher levels of corrosion resistance than zinc electroplating of equivalent thicknesses and is particularly effective in marine environments. Cadmium is extremely toxic and although cadmium plated products are not a high risk hazard, cadmium coated products should not be used in applications involving contact with food, beverages and potable (drinking) water.

Features & Benefits

- Moderate levels of corrosion resistance
- Even coating distribution across threads
- Commonly used and proven in application
- Very low friction coefficient
- Does not produce "white rust"

Typical Uses

Applications in moderately corrosive environments including industrial and marine environments of Categories C3 to C4 as classified by ISO 9223

Coating Properties

Colour	Silver/grey or black
Finish / appearance	Bright metallic
Torquing coefficient	Unlubricated 0.17
Service Temperature	up to 160°C
Salt Spray Resistance	Moderate (up to 2000hrs)
Chemical Resistance	
Solvent Resistance	Good
Acid Resistance	Poor
Alkali Resistance	Good
Conformance Details	ASTM B766
Thickness	12 µm (nominal)

Limitations

- Service life limited by thin coating thickness
- Requires light lubrication during tightening
- Cadmium is extremely toxic
- Not suitable in contact with potable water
- Not suitable use in contact with food and beverages.
- Hazardous to the environment



Xylar/Xylan Series 1424

Coating Type: Organic

Coating Description

This coating is based on a resin which is cold applied and thermally cured to provide a resilient coating with high lubricity and a very low friction coefficient. This coating also provides moderate levels of corrosion protection and can be used across a wide spectrum of service temperatures. The corrosion resistance is higher than PTFE.

Features & Benefits

Moderate levels of corrosion resistance
Very low friction coefficient
No further lubrication required
Wide range of service temperatures
Moderate chemical resistance.
Eliminates thread galling and seizing

Typical Uses

Applications where low assembly friction is required and in moderate corrosive environments including industrial and marine environments of Categories C5 as classified by ISO 9223

Coating Properties

Colour	Blue
Finish / appearance	Satin / smooth
Torquing coefficient	Unlubricated 0.10
Service Temperature	-40°C to 205°C
Salt Spray Resistance	moderate (up to 1000hrs)
Chemical Resistance	
Solvent Resistance	Moderate
Acid Resistance	Moderate
Alkali Resistance	Moderate
Conformance Details	As to Bremick specifications
Thickness	25µm

Limitations

Service life limited by coating thickness



PTFE

Coating Type: Organic

Coating Description

Polytetrafluoroethylene (PTFE) resin is in a class of paraffinic polymers that have some or all of the hydrogen replaced by fluoride. PTFE can be applied directly onto threaded components, can be used in a wide range of service temperatures, is flame resistant, offers moderate levels of corrosion protection and has one of the lowest friction coefficients of all available coatings. The coating is equivalent to 31 µm of zinc.

Features & Benefits

Moderate levels of corrosion resistance
Even coating distribution across threads
Extremely low friction coefficient
No lubrication required
Wide range of service temperatures
Excellent chemical resistance
Good abrasion resistance.
Tested and certified for use in Severe Marine Environments

Typical Uses

Applications where low assembly friction is required and in highly corrosive environments including industrial and marine environments of Categories C5 as classified by ISO 9223

Coating Properties

Colour	Blue, Green or Yellow
Finish / appearance	Satin / smooth
Torquing coefficient	Unlubricated 0.10
Service Temperature	-270°C to 260°C
Salt Spray Resistance	Excellent (up to 5000hrs)
Chemical Resistance	
Solvent Resistance	Excellent
Acid Resistance	Excellent
Alkali Resistance	Excellent
Conformance Details	As per Bremick specifications
Thickness	25 µm

Limitations

Service life limited by coating thickness



MOLYBOND

Coating Type: Organic

Coating Description

Molybond is a proprietary Molybdenum disulphide dry film lubrication coating that is generally applied over zinc phosphate coated stud bolts and nuts primarily to provide improved lubricity. This coating also provides moderate levels of corrosion protection and can be used across a wide spectrum of service temperatures. The coating is equivalent to 31 µm of zinc.

Features & Benefits

Moderate levels of corrosion resistance
 Very low friction coefficient
 No further lubrication required
 Wide range of service temperatures
 Moderate chemical resistance.
 Tested and certified for use in Severe Marine Environments

Typical Uses

Applications where low assembly friction is required and in moderate corrosive environments including industrial and marine environments of Categories C4 as classified by ISO 9223

Coating Properties

Colour	Grey / Black
Finish / appearance	Satin / smooth
Torquing coefficient	Unlubricated 0.18
Service Temperature	-70°C to 300°C
Salt Spray Resistance	moderate (up to 300hrs)
Chemical Resistance	
Solvent Resistance	Moderate
Acid Resistance	Moderate
Alkali Resistance	Moderate
Conformance Details	As per Bremick specifications
Thickness	up to 10 µm

Limitations

Service life limited by coating thickness



Bremkote ZTX

Coating Type: Composite Coating

Coating Description

Bremkote ZTX is a proprietary composite coating consisting of a high performance cold applied metallic coating that is over coated with a high lubricity, thermally cured organic resin. The combined characteristics of this hybrid dual coating system provides excellent levels of corrosion protection and dry film lubrication across a wide spectrum of service temperatures

Features & Benefits

Ideal protection system for carbon steel
 Very high levels of corrosion resistance
 Very low friction coefficient
 No further lubrication required
 Wide range of service temperatures
 Moderate chemical resistance.
 Eliminates thread galling and seizing
 Maximum coating depth
 Long service life
 Low maintenance

Typical Uses

Applications where low assembly friction is required and in extreme corrosive environments including severe industrial and severe marine environments of Categories C5 as classified by ISO 9223

Coating Properties

Colour	Blue
Finish / appearance	Satin / smooth
Torquing coefficient	Unlubricated 0.10
Service Temperature	-40°C to 205°C
Salt Spray Resistance	Excellent (up to 3000hrs)
Chemical Resistance	
Solvent Resistance	Moderate
Acid Resistance	Moderate
Alkali Resistance	Moderate
Conformance Details	As per Bremick specifications
Combined	Thickness Up to 50µm

Limitations

May require thread adjustment due to heavy coating thickness
 Suitable for use on Carbon Steels only



Bremkote EZN

Coating Type: Inorganic

Coating Description

Bremkote EZN is a proprietary coating offers exceptional corrosion protection consisting of a cold applied plating alloy that is applied in coating thicknesses of 12–20 micron metres. Bremkote EZN provides higher levels of corrosion resistance than other inorganic plating alloys of similar coating thicknesses.

Features & Benefits

High levels of corrosion resistance
Even coating distribution across threads
Commonly used and proven in application
Very low friction coefficient
Proven

Typical Uses

Applications in highly corrosive environments including industrial and marine environments of Categories C5 as classified by ISO 9223

Coating Properties

Colour	Silver/grey
Finish / appearance	Bright metallic
Torquing coefficient	Unlubricated 0.22
Service Temperature	Up to 160°C
Salt Spray Resistance	Moderate (up to 4500 hrs)
Chemical Resistance	
Solvent Resistance	Good
Acid Resistance	Moderate
Alkali Resistance	Good
Conformance Details	As per Bremick specification
Thickness 1	12–20 µm (nominal)

Limitations

Requires light lubrication during tightening

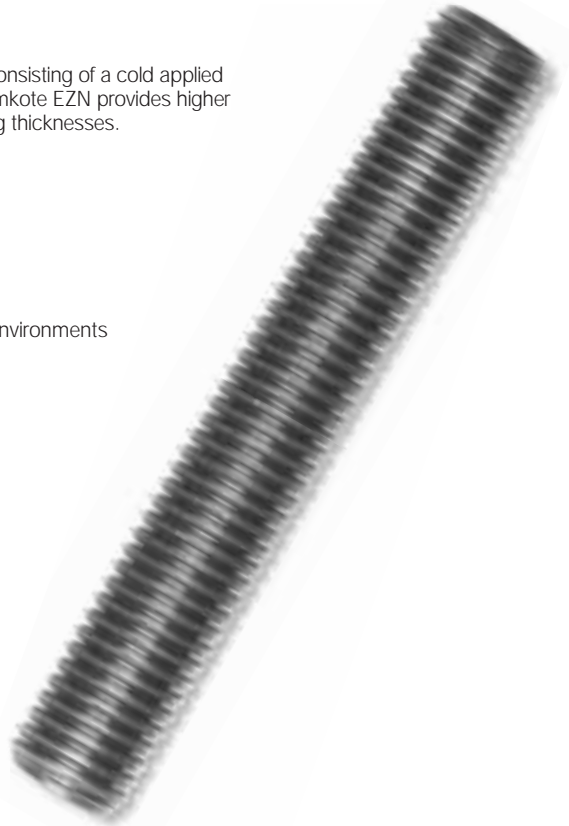

Bremkote CDX

Coating Type: Composite Coating

Coating Description

Bremkote CDX is a proprietary composite coating consisting of a high performance cold applied metallic coating that is over coated with a high lubricity, thermally cured organic resin with minimal coating depth. The combined characteristics of this hybrid dual coating system provides excellent levels of corrosion protection and dry film lubrication across a wide spectrum of service temperatures

Features & Benefits

Can be applied to most metals
Very high levels of corrosion resistance
Very low friction coefficient
Minimal coating depth
No further lubrication required
Wide range of service temperatures
Moderate chemical resistance.
Eliminates thread galling and seizing
Long service life
Low maintenance

Typical Uses

Applications where low assembly friction is required and in highly corrosive environments including severe industrial and severe marine environments of Categories C5 as classified by ISO 9223

Coating Properties

Colour	Blue
Finish / appearance	Satin / smooth
Torquing coefficient	Unlubricated 0.10
Service Temperature	-40°C to 160°C
Salt Spray Resistance	Excellent (up to 3000hrs)
Chemical Resistance	
Solvent Resistance	Moderate
Acid Resistance	Moderate
Alkali Resistance	Moderate
Conformance Details	As per Bremick specifications
Combined Thickness	Up to 37µm



Bremkote ZNX

Coating Type: Composite Coating

Coating Description

Bremkote ZNX is a proprietary composite coating uniquely engineered for exceptional service life even when exposed to extreme corrosive environments. Bremkote ZNX coating system consists of a high performance cold applied metallic coating that is over coated with a high lubricity, thermally cured organic resin with minimal coating depth. The combined characteristics of this hybrid dual coating system provides the ultimate level of corrosion protection with exceptional dry film lubrication across a wide spectrum of service temperatures

Features & Benefits

- Can be applied to most metals
- Very high levels of corrosion resistance
- Very low friction coefficient
- No further lubrication required
- Wide range of service temperatures
- Moderate chemical resistance.
- Eliminates thread galling and seizing
- Long service life
- Low maintenance

Typical Uses

Applications where low assembly friction is required and in extreme corrosive environments including severe industrial and severe marine environments of Categories C5 as classified by ISO 9223

Coating Properties

Colour	Blue
Finish / appearance	Satin / smooth
Torquing coefficient	Unlubricated 0.10
Service Temperature	-40°C to 205°C
Salt Spray Resistance	Excellent (up to 3000hrs)
Chemical Resistance	
Solvent Resistance	Moderate
Acid Resistance	Moderate
Alkali Resistance	Moderate
Conformance Details	As to Bremick specifications
Combined Thickness	Up to 45µm



Bremkote EZP

Coating Type: Composite Organic Coating

Coating Description

Bremkote EZP is a proprietary composite coating uniquely engineered to enhance the coating characteristics of generic organically coated products. Bremkote EZP coating system consists of a cold applied metallic coating that is over coated with an organic coating with very high lubricity levels and excellent chemical resistance. The combined characteristics of this hybrid dual coating system provides optimum levels of corrosion protection together with the highest possible dry film lubrication and chemical resistance across a wide spectrum of service temperatures

Features & Benefits

- Can be applied to most metals
- Very high levels of corrosion resistance
- High resistance to chemical exposure
- Very low friction coefficient
- No further lubrication required
- Wide range of service temperatures
- Moderate chemical resistance.
- Eliminates thread galling and seizing
- Long service life
- Low maintenance

Typical Uses

Applications where low assembly friction is required, high levels of chemical exposure, including severe industrial environments and severe marine environments of Categories C5 as classified by ISO 9223

Coating Properties

Colour	Blue, Green or Yellow
Finish / appearance	Satin / smooth
Torquing coefficient	Unlubricated 0.10
Service Temperature	-270°C to 260°C
Salt Spray Resistance	Excellent (up to 5000hrs)
Chemical Resistance	
Solvent Resistance	Excellent
Acid Resistance	Excellent
Alkali Resistance	Excellent
Conformance Details	As per Bremick specifications.
Thickness	up to 45 µm



Chemical composition and mechanical properties Stud Bolts & Heavy Hex Bolts - Grades B7, B7M, L7, L7M & B16

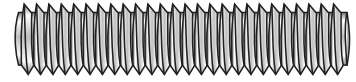

ASTM Studbolt Grade	B7	B7M	L7	L7M	B16
Marking Symbol	BF B7	BF B7M	BF L7	BF L7M	BF B16
Service Temperature	-100°C to 400°C	-30°C to 400°C	-100°C to 400°C	-73°C to -30°C	-0°C to -520°C
ASTM Specification	ASTM A193/A 193M	ASTM A193/A 193M	ASTM A320/A320M	ASTM A320/A320M	ASTM A193/A 193M
AISI Material Specification	4140	4140	4140	4140	Chromium/Moly/ Vanadium

Chemical Composition %

Carbon	0.37-0.49	0.37-0.49	0.38-0.48	0.38-0.48	0.36-0.47
Manganese	0.65-1.10	0.65-1.10	0.75-1.00	0.75-1.00	0.45-0.70
Phosphorous	0.035 max	0.035 max	0.035 max	0.035 max	0.035 max
Sulphur	0.040 max	0.040 max	0.040 max	0.040 max	0.040 max
Silicon	0.15-0.35	0.15-0.35	0.15-0.35	0.15-0.35	0.15-0.35
Chromium	0.75-1.20	0.75-1.20	0.80-1.10	0.80-1.10	0.80-1.15
Molybdenum	0.15-0.25	0.15-0.25	0.15-0.25	0.15-0.25	0.50-0.65
Vanadium	-	-	-	-	0.25-0.35
Nickel	-	-	-	-	-

Mechanical Properties

Diameter	2 1/2" and Under	4" and under	2 1/2" and Under	2 1/2" and Under	2 1/2" and Under
Minimum Tensile Strength	125 ksi min (860MPa)	100 ksi min (690MPa)	125 ksi min (860MPa)	100 ksi min (690MPa)	125 ksi min (860MPa)
Yield Strength Min, 0.2% Offset	105 ksi min (720MPa)	80 ksi min (550MPa)	105 ksi min (720MPa)	80 ksi min (550MPa)	105 ksi min (725MPa)
Minimum Elongation in 4D	16 % min	18% min	16 % min	18% min	18 % min
Minimum Reduction of Area	50 % min	50 % min	50 % min	50 % min	50 % min
Maximum Brinell Hardness	321 HB max (35 HRC max)	235 HB max (99 HRB max)	321 HB max (35 HRC max)	235 HB max (99 HRB max)	321 HB max (35 HRC max)

Diameter	Over 2 1/2" to 4"	4" and Over	Over 2 1/2" to 4"	-	Over 2 1/2" to 4"
Minimum Tensile Strength	115 ksi min (795MPa)	100 ksi min (690MPa)	115 ksi min (795MPa)	-	110 ksi min (760MPa)
Yield Strength Min, 0.2% Offset	95 ksi min (655MPa)	75 ksi min (515MPa)	95 ksi min (655MPa)	-	95 ksi min (655MPa)
Minimum Elongation in 4D	16 % min	18% min	16 % min	-	17 % min
Minimum Reduction of Area	50 % min	50 % min	50 % min	-	45 % min
Maximum Brinell Hardness	321 HB max (35 HRC max)	235 HB max (99 HRB max)	321 HB max (99 HRB max)	-	321 HB max (35 HRC max)

CONTINUED OVER PAGE ►

Chemical composition and mechanical properties Stud Bolts & Heavy Hex Bolts - Grades B7, B7M, L7, L7M & B16

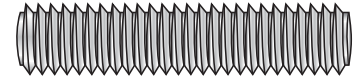

Mechanical Properties (continued)

ASTM Studbolt Grade	B7	B7M	L7	L7M	B16
Diameter	4" and Over		Over 2 1/2" to 4"		Over 2 1/2" to 4"
Minimum Impact Value @ -150°F (-101°C) for average of each set of three specimens, 10mm x 10mm			20 ft.lbf min (27 J min at -73 °C)	40 ft.lbf min (54 J min)	
Minimum Impact Value @ -150°F (-101°C) permitted for one specimen only of a set, 10mm x 10mm					
ASTM Compatible Nut	A194 Grade 2H	A194 Grade 2HM	A194 Grade 7 & Grade 4L	A194 Grade 7M	A194 Grade 7 & Grade 4L

Note: Other Grades of Studbolts, Heavy Hex Bolts and Nuts may be manufactured to order.
Please refer to relevant standards for more detailed information.
Service Temperatures refer to actual metal temperatures.

Chemical composition and mechanical properties

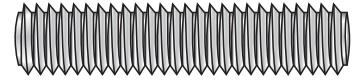

Stud Bolts & Heavy Hex Bolts -

Grade B8 CL1, B8 CL2, B8M CL1 & B8M CL2

ASTM Studbolt Grade	B8 Class 1	B8 Class 2	B8M Class 1	B8M Class 2
Marking Symbol	BF B8	BF <u>B8SH</u>	BF B8M	BF <u>B8MSH</u>
Service Temperature	-250°C to 575°C	-250°C to 575°C	-250°C to 600°C	-250°C to 600°C
ASTM Specification	ASTM A320/A320M	ASTM A193/A193M ASTM A320/A320M	ASTM A320/A320M	ASTM A193/A193M ASTM A320/A320M
AISI Material	Type 304 Stainless Steel	Type 304 Stainless Strain Hardened	Type 316 Stainless Steel	Type 316 Stainless Strain Hardened

Chemical Composition %

Carbon	0.08 max	0.08 max	0.08 max	0.08 max
Manganese	2.00 max	2.00 max	2.00 max	2.00 max
Phosphorous	0.045 max	0.045 max	0.045 max	0.045 max
Sulphur	0.03 max	0.03 max	0.03 max	0.03 max
Silicon	1.00 max	1.00 max	1.00 max	1.00 max
Chromium	18.0-20.0	18.0-20.0	16.0-18.0	16.0-18.0
Molybdenum	-	-	2.00-3.00	2.00-3.00
Vanadium	-	-	-	-
Nickel	8.0-11.0	8.0-11.0	10.0-14.0	10.0-14.0

Chemical composition and mechanical properties Stud Bolts & Heavy Hex Bolts - Grade B8 CL1, B8 CL2, B8M CL1 & B8M CL2

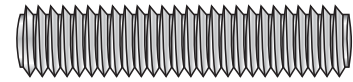

Mechanical Properties

ASTM Studbolt Grade	B8 Class 1	B8 Class 2	B8M Class 1	B8M Class 2
Diameter	All Diameters	3/4" and under	All Diameters	3/4" and under
Minimum Tensile Strength	75 ksi min (515MPa)	125 ksi min (860MPa)	75 ksi min (515MPa)	110 ksi min (760MPa)
Yield Strength Min, 0.2% Offset	30 ksi min (205MPa)	100 ksi min (690MPa)	30 ksi min (205MPa)	95 ksi min (655MPa)
Minimum Elongation in 4D	30 % min	12 % min	30 % min	15 % min
Minimum Reduction of Area	50 % min	35 % min	50 % min	45 % min
Maximum Brinell Hardness	223 HB max (96 HRB max)	321 HB max (35 HRC max)	223 HB max (96 HRB max)	321 HB max (35 HRC max)
Diameter	Over 3/4" to 1", incl		Over 3/4" to 1", incl	
Minimum Tensile Strength	-	115 ksi min (795MPa)	-	100 ksi min (690MPa)
Yield Strength Min, 0.2% Offset	-	80 ksi min (550MPa)	-	80 ksi min (550MPa)
Minimum Elongation in 4D	-	15 % min	-	20 % min
Minimum Reduction of Area	-	35 % min	-	45 % min
Maximum Brinell Hardness	-	321 HB max (35 HRC max)	-	321 HB max (35 HRC max)
Diameter	Over 1" to 1 1/4", incl		Over 1" to 1 1/4", incl	
Minimum Tensile Strength	-	105 ksi min (725MPa)	-	95 ksi min (655MPa)
Yield Strength Min, 0.2% Offset	-	65 ksi min (450MPa)	-	65 ksi min (450MPa)
Minimum Elongation in 4D	-	20 % min	-	25 % min
Minimum Reduction of Area	-	35 % min	-	45 % min
Maximum Brinell Hardness	-	321 HB max (35 HRC max)	-	321 HB max (35 HRC max)

CONTINUED OVER PAGE ►

Chemical composition and mechanical properties

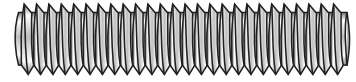

Stud Bolts & Heavy Hex Bolts -
Grade B8 CL1, B8 CL2, B8M CL1 & B8M CL2

Mechanical Properties (continued)

ASTM Studbolt Grade	B8 Class 1	B8 Class 2	B8M Class 1	B8M Class 2
Diameter	Over 1 1/4" to 1 1/2", incl		Over 1 1/4" to 1 1/2", incl	
Minimum Tensile Strength	-	100 ksi min (690MPa)	-	90 ksi min (620MPa)
Yield Strength Min, 0.2% Offset	-	50 ksi min (345MPa)	-	50 ksi min (345MPa)
Minimum Elongation in 4D	-	28 % min	-	30 % min
Minimum Reduction of Area	-	45 % min	-	45 % min
Maximum Brinell Hardness	-	321 HB max (35 HRC max)	-	321 HB max (35 HRC max)
Minimum Impact Value @ -150°F (-101°C) for average of each set of three specimens, 10mm x 10mm				
Minimum Impact Value @ -150°F (-101°C) permitted for one specimen only of a set, 10mm x 10mm				
ASTM Compatible Nut	A194 Grade 8	A194 Grade 8	A194 Grade 8M	A194 Grade 8M

Note: Other Grades of Studbolts, Heavy Hex Bolts and Nuts may be manufactured to order.

Please refer to relevant standards for more detailed information.

Service Temperatures refer to actual metal temperatures.

MECHANICAL PROPERTIES



Mechanical properties of stud bolts and heavy hex bolts

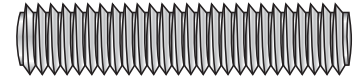

MECHANICAL PROPERTIES - B7

High Temperature

ASTM A 193/A 193M

GRADE B7 PETROCHEMICAL STUD BOLT - MECHANICAL PROPERTIES								
Nominal Size	Thread	TPI	Stress Area	Minimum Tensile Strength	Minimum Yield Strength (0.2% offset)	Minimum Tensile Load	Minimum Yield Load	Proof Load
Inches			in ²	lbf/in ²	lbf/in ²	lbf	lbf	lbf
3/8"	UNC	16	0.0775	125,000	105,000	9,688	8,138	7,324
1/2"	UNC	13	0.142	125,000	105,000	17,750	14,910	13,419
5/8"	UNC	11	0.226	125,000	105,000	28,250	23,730	21,357
3/4"	UNC	10	0.334	125,000	105,000	41,750	35,070	31,563
7/8"	UNC	9	0.462	125,000	105,000	57,750	48,510	43,659
1"	UNC	8	0.606	125,000	105,000	75,750	63,630	57,267
1.1/8"	UN8	8	0.790	125,000	105,000	98,750	82,950	74,655
1.1/4"	UN8	8	1.000	125,000	105,000	125,000	105,000	94,500
1.3/8"	UN8	8	1.23	125,000	105,000	153,750	129,150	116,235
1.1/2"	UN8	8	1.49	125,000	105,000	186,500	156,660	140,994
1.5/8"	UN8	8	1.78	125,000	105,000	222,500	186,900	168,210
1.3/4"	UN8	8	2.08	125,000	105,000	260,000	218,400	196,560
1.7/8"	UN8	8	2.41	125,000	105,000	301,250	253,050	227,745
2"	UN8	8	2.77	125,000	105,000	346,250	290,850	261,765
2.1/4"	UN8	8	3.56	125,000	105,000	445,000	373,800	336,420
2.1/2"	UN8	8	4.44	125,000	105,000	555,000	466,200	419,580
2.3/4"	UN8	8	5.43	115,000	95,000	624,450	515,850	464,265
3"	UN8	8	6.51	115,000	95,000	748,650	618,450	556,605
3.1/4"	UN8	8	7.69	115,000	95,000	884,350	730,550	657,495
3.1/2"	UN8	8	8.96	115,000	95,000	1,030,400	851,200	766,080
3.3/4"	UN8	8	10.34	115,000	95,000	1,189,100	982,300	884,070
4"	UN8	8	11.81	115,000	95,000	1,358,150	1,121,950	1,009,755
4" to 7"				100,000	75,000			

Minimum Tensile Loads displayed are Minimum Ultimate Capacities, derived from Stress Area and Minimum Tensile Strength.

Minimum Yield Loads displayed are derived from Stress Area and Minimum Tensile Strength.

Values displayed for Proof Load are derived from Stress Area and Minimum Yield Strength and are 90% of Minimum Yield Load.

Values displayed are NOT design loads, design professionals should apply appropriate safety factors.

MECHANICAL PROPERTIES



Mechanical properties of stud bolts and heavy hex bolts

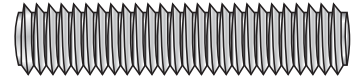

MECHANICAL PROPERTIES - B16

High Temperature

ASTM A 193/A 193M

GRADE B16 PETROCHEMICAL STUD BOLT - MECHANICAL PROPERTIES								
Nominal Size	Thread	TPI	Stress Area	Minimum Tensile Strength	Minimum Yield Strength (0.2% offset)	Minimum Tensile Load	Minimum Yield Load	Proof Load
Inches			in ²	lbf/in ²	lbf/in ²	lbf	lbf	lbf
3/8"	UNC	16	0.0775	125,000	105,000	9,688	8,138	7,324
1/2"	UNC	13	0.142	125,000	105,000	17,750	14,910	13,419
5/8"	UNC	11	0.226	125,000	105,000	28,250	23,730	21,357
3/4"	UNC	10	0.334	125,000	105,000	41,750	35,070	31,563
7/8"	UNC	9	0.462	125,000	105,000	57,750	48,510	43,659
1"	UNC	8	0.606	125,000	105,000	75,750	63,630	57,267
1.1/8"	UN8	8	0.790	125,000	105,000	98,750	82,950	74,655
1.1/4"	UN8	8	1.000	125,000	105,000	125,000	105,000	94,500
1.3/8"	UN8	8	1.23	125,000	105,000	153,750	129,150	116,235
1.1/2"	UN8	8	1.49	125,000	105,000	186,500	156,660	140,994
1.5/8"	UN8	8	1.78	125,000	105,000	222,500	186,900	168,210
1.3/4"	UN8	8	2.08	125,000	105,000	260,000	218,400	196,560
1.7/8"	UN8	8	2.41	125,000	105,000	301,250	253,050	227,745
2"	UN8	8	2.77	125,000	105,000	346,250	290,850	261,765
2.1/4"	UN8	8	3.56	125,000	105,000	445,000	373,800	336,420
2.1/2"	UN8	8	4.44	125,000	105,000	555,000	466,200	419,580
2.3/4"	UN8	8	5.43	110,000	95,000	597,300	515,850	464,265
3"	UN8	8	6.51	110,000	95,000	716,100	618,450	556,605
3.1/4"	UN8	8	7.69	110,000	95,000	845,900	730,550	657,495
3.1/2"	UN8	8	8.96	110,000	95,000	985,600	851,200	766,080
3.3/4"	UN8	8	10.34	110,000	95,000	1,137,400	982,300	884,070
4"	UN8	8	11.81	110,000	95,000	1,299,100	1,121,950	1,009,755
4" to 7"				100,000	85,000			

Minimum Tensile Loads displayed are Minimum Ultimate Capacities, derived from Stress Area and Minimum Tensile Strength.

Minimum Yield Loads displayed are derived from Stress Area and Minimum Tensile Strength.

Values displayed for Proof Load are derived from Stress Area and Minimum Yield Strength and are 90% of Minimum Yield Load.

Values displayed are NOT design loads, design professionals should apply appropriate safety factors.

MECHANICAL PROPERTIES



Mechanical properties of stud bolts and heavy hex bolts

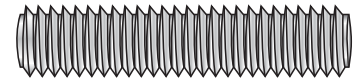

MECHANICAL PROPERTIES - L7, L7A, L7B, L7C, L70, L71, L72 & L73

For Low Temperature Service

ASTM A 320 / 320M

PETROCHEMICAL STUD BOLT - MECHANICAL PROPERTIES								
Nominal Size	Thread	TPI	Stress Area	Minimum Tensile Strength	Minimum Yield Strength (0.2% offset)	Minimum Tensile Load	Minimum Yield Load	Proof Load
Inches			in ²	lbf/in ²	lbf/in ²	lbf	lbf	lbf
3/8"	UNC	16	0.0775	125,000	105,000	9,688	8,138	7,324
1/2"	UNC	13	0.142	125,000	105,000	17,750	14,910	13,419
5/8"	UNC	11	0.226	125,000	105,000	28,250	23,730	21,357
3/4"	UNC	10	0.334	125,000	105,000	41,750	35,070	31,563
7/8"	UNC	9	0.462	125,000	105,000	57,750	48,510	43,659
1"	UNC	8	0.606	125,000	105,000	75,750	63,630	57,267
1.1/8"	UN8	8	0.790	125,000	105,000	98,750	82,950	74,655
1.1/4"	UN8	8	1.000	125,000	105,000	125,000	105,000	94,500
1.3/8"	UN8	8	1.23	125,000	105,000	153,750	129,150	116,235
1.1/2"	UN8	8	1.49	125,000	105,000	186,500	156,660	140,994
1.5/8"	UN8	8	1.78	125,000	105,000	222,500	186,900	168,210
1.3/4"	UN8	8	2.08	125,000	105,000	260,000	218,400	196,560
1.7/8"	UN8	8	2.41	125,000	105,000	301,250	253,050	227,745
2"	UN8	8	2.77	125,000	105,000	346,250	290,850	261,765
2.1/4"	UN8	8	3.56	125,000	105,000	445,000	373,800	336,420
2.1/2"	UN8	8	4.44	125,000	105,000	555,000	466,200	419,580
2.3/4"	UN8	8	5.43					
3"	UN8	8	6.51					
3.1/4"	UN8	8	7.69					
3.1/2"	UN8	8	8.96					
3.3/4"	UN8	8	10.34					
4"	UN8	8	11.81					
4" to 7"								

Not listed in ASTM A320/A320M

Minimum Tensile Loads displayed are Minimum Ultimate Capacities, derived from Stress Area and Minimum Tensile Strength.

Minimum Yield Loads displayed are derived from Stress Area and Minimum Tensile Strength.

Values displayed for Proof Load are derived from Stress Area and Minimum Yield Strength and are 90% of Minimum Yield Load.

Values displayed are NOT design loads, design professionals should apply appropriate safety factors.

Diameters over 2 1/2" are uncommon and conforming Heat Numbers may not be available.

MECHANICAL PROPERTIES



Mechanical properties of stud bolts and heavy hex bolts

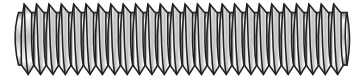

MECHANICAL PROPERTIES - L7M & B7M ASTM A 320 / 320M and ASTM A193/A193M

PETROCHEMICAL STUD BOLT - MECHANICAL PROPERTIES								
Nominal Size	Thread	TPI	Stress Area	Minimum Tensile Strength	Minimum Yield Strength (0.2% offset)	Minimum Tensile Load	Minimum Yield Load	Proof Load
Inches			in ²	lbf/in ²	lbf/in ²	lbf	lbf	lbf
3/8"	UNC	16	0.0775	100,000	80,000	7,750	6,200	5,580
1/2"	UNC	13	0.142	100,000	80,000	14,200	11,360	10,224
5/8"	UNC	11	0.226	100,000	80,000	22,600	18,080	16,272
3/4"	UNC	10	0.334	100,000	80,000	33,400	26,720	24,048
7/8"	UNC	9	0.462	100,000	80,000	46,200	36,960	33,264
1"	UNC	8	0.606	100,000	80,000	60,600	48,480	43,632
1.1/8"	UN8	8	0.790	100,000	80,000	79,000	63,200	56,880
1.1/4"	UN8	8	1.000	100,000	80,000	100,000	80,000	72,000
1.3/8"	UN8	8	1.23	100,000	80,000	123,000	98,400	88,560
1.1/2"	UN8	8	1.49	100,000	80,000	149,200	119,360	107,424
1.5/8"	UN8	8	1.78	100,000	80,000	178,000	142,400	128,160
1.3/4"	UN8	8	2.08	100,000	80,000	208,000	166,400	149,760
1.7/8"	UN8	8	2.41	100,000	80,000	241,000	192,800	173,520
2"	UN8	8	2.77	100,000	80,000	277,000	221,600	199,440
2.1/4"	UN8	8	3.56	100,000	80,000	356,000	284,800	256,320
2.1/2"	UN8	8	4.44	100,000	80,000	444,000	355,200	319,680
2.3/4"	UN8	8	5.43					
3"	UN8	8	6.51					
3.1/4"	UN8	8	7.69					
3.1/2"	UN8	8	8.96					
3.3/4"	UN8	8	10.34					
4"	UN8	8	11.81					
4" to 7"								

Not listed in ASTM A320/A320M

Minimum Tensile Loads displayed are Minimum Ultimate Capacities, derived from Stress Area and Minimum Tensile Strength.

Minimum Yield Loads displayed are derived from Stress Area and Minimum Tensile Strength.

Values displayed for Proof Load are derived from Stress Area and Minimum Yield Strength and are 90% of Minimum Yield Load.

Values displayed are NOT design loads, design professionals should apply appropriate safety factors.

Diameters over 2 1/2" are uncommon and conforming Heat Numbers may not be available.

Mechanical properties of stud bolts and heavy hex bolts

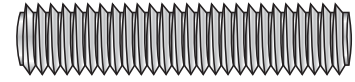

**MECHANICAL PROPERTIES - Class 1 - B8, B8M, B8C, B8P, B8F, B8T, B8LN, & B8MLN
ASTM A 320 / 320M and ASTM A193/A193M**

PETROCHEMICAL STUD BOLT - MECHANICAL PROPERTIES								
Nominal Size	Thread	TPI	Stress Area	Minimum Tensile Strength	Minimum Yield Strength (0.2% offset)	Minimum Tensile Load	Minimum Yield Load	Proof Load
Inches			in ²	lbf/in ²	lbf/in ²	lbf	lbf	lbf
3/8"	UNC	16	0.0775	75,000	30,000	5,813	2,325	2,093
1/2"	UNC	13	0.142	75,000	30,000	10,650	4,260	3,834
5/8"	UNC	11	0.226	75,000	30,000	16,950	6,780	6,102
3/4"	UNC	10	0.334	75,000	30,000	25,050	10,020	9,018
7/8"	UNC	9	0.462	75,000	30,000	34,650	13,860	12,474
1"	UNC	8	0.606	75,000	30,000	45,450	18,180	16,362
1.1/8"	UN8	8	0.790	75,000	30,000	59,250	23,700	21,330
1.1/4"	UN8	8	1.000	75,000	30,000	75,000	30,000	27,000
1.3/8"	UN8	8	1.23	75,000	30,000	92,250	36,900	33,210
1.1/2"	UN8	8	1.49	75,000	30,000	111,900	44,760	40,284
1.5/8"	UN8	8	1.78	75,000	30,000	133,500	53,400	48,060
1.3/4"	UN8	8	2.08	75,000	30,000	156,000	62,400	56,160
1.7/8"	UN8	8	2.41	75,000	30,000	180,750	72,300	65,070
2"	UN8	8	2.77	75,000	30,000	207,750	83,100	74,790
2.1/4"	UN8	8	3.56	75,000	30,000	267,000	106,800	96,120
2.1/2"	UN8	8	4.44	75,000	30,000	333,000	133,200	119,880
2.3/4"	UN8	8	5.43	75,000	30,000	407,250	162,900	146,610
3"	UN8	8	6.51	75,000	30,000	488,250	195,300	175,770
3.1/4"	UN8	8	7.69	75,000	30,000	576,750	230,700	207,630
3.1/2"	UN8	8	8.96	75,000	30,000	672,000	268,800	241,920
3.3/4"	UN8	8	10.34	75,000	30,000	775,500	310,200	279,180
4"	UN8	8	11.81	75,000	30,000	885,750	354,300	318,870
4" to 7"				75,000	30,000			

Minimum Tensile Loads displayed are Minimum Ultimate Capacities, derived from Stress Area and Minimum Tensile Strength.

Minimum Yield Loads displayed are derived from Stress Area and Minimum Tensile Strength.

Values displayed for Proof Load are derived from Stress Area and Minimum Yield Strength and are 90% of Minimum Yield Load.

Values displayed are NOT design loads, design professionals should apply appropriate safety factors.

MECHANICAL PROPERTIES



Mechanical properties of stud bolts and heavy hex bolts

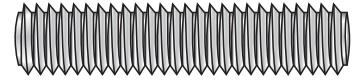

MECHANICAL PROPERTIES - Class 2 - B8M

Low & High Temperature Service

ASTM A 320 / 320M & ASTM 193/A 193M

GRADE B8M Class 2 PETROCHEMICAL STUD BOLT - MECHANICAL PROPERTIES								
Nominal Size	Thread	TPI	Stress Area	Minimum Tensile Strength	Minimum Yield Strength (0.2% offset)	Minimum Tensile Load	Minimum Yield Load	Proof Load
Inches			in ²	lbf/in ²	lbf/in ²	lbf	lbf	lbf
3/8"	UNC	16	0.0775	110,000	95,000	8,525	7,363	6,626
1/2"	UNC	13	0.142	110,000	95,000	15,620	13,490	12,141
5/8"	UNC	11	0.226	110,000	95,000	24,860	21,470	19,323
3/4"	UNC	10	0.334	110,000	95,000	36,740	31,730	28,557
7/8"	UNC	9	0.462	100,000	80,000	46,200	36,960	33,264
1"	UNC	8	0.606	100,000	80,000	60,600	48,480	43,632
1.1/8"	UN8	8	0.790	95,000	65,000	75,050	51,350	46,215
1.1/4"	UN8	8	1.000	95,000	65,000	95,000	65,000	58,500
1.3/8"	UN8	8	1.23	90,000	50,000	110,700	61,500	55,350
1.1/2"	UN8	8	1.49	90,000	50,000	134,280	74,600	67,140
1.5/8"	UN8	8	1.78					
1.3/4"	UN8	8	2.08					
1.7/8"	UN8	8	2.41					
2"	UN8	8	2.77					
2.1/4"	UN8	8	3.56					
2.1/2"	UN8	8	4.44					
2.3/4"	UN8	8	5.43					
3"	UN8	8	6.51					
3.1/4"	UN8	8	7.69					
3.1/2"	UN8	8	8.96					
3.3/4"	UN8	8	10.34					
4"	UN8	8	11.81					
4" to 7"								

Not listed in ASTM A 320/A 320M or ASTM A 193/A 193M

Minimum Tensile Loads displayed are Minimum Ultimate Capacities, derived from Stress Area and Minimum Tensile Strength.

Minimum Yield Loads displayed are derived from Stress Area and Minimum Tensile Strength.

Values displayed for Proof Load are derived from Stress Area and Minimum Yield Strength and are 90% of Minimum Yield Load.

Values displayed are NOT design loads, design professionals should apply appropriate safety factors.

Austenitic steels in the strain hardened (work hardened) condition may not show uniform properties in sizes over 1.1/2" in diameter.

Mechanical properties of stud bolts and heavy hex bolts

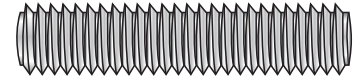

MECHANICAL PROPERTIES - Class 2 - B8, B8C, B8P, B8F & B8T

Low & High Temperature Service

ASTM A 320 / 320M and ASTM A193/A 193M

PETROCHEMICAL STUD BOLT - MECHANICAL PROPERTIES								
Nominal Size	Thread	TPI	Stress Area	Minimum Tensile Strength	Minimum Yield Strength (0.2% offset)	Minimum Tensile Load	Minimum Yield Load	Proof Load
Inches			in ²	lbf/in ²	lbf/in ²	lbf	lbf	lbf
3/8"	UNC	16	0.0775	125,000	100,000	9,688	7,750	6,975
1/2"	UNC	13	0.142	125,000	100,000	17,750	14,200	12,780
5/8"	UNC	11	0.226	125,000	100,000	28,250	22,600	20,340
3/4"	UNC	10	0.334	125,000	100,000	41,750	33,400	30,060
7/8"	UNC	9	0.462	115,000	80,000	53,130	36,960	33,264
1"	UNC	8	0.606	115,000	80,000	69,690	48,480	43,632
1.1/8"	UN8	8	0.790	105,000	65,000	82,950	51,350	46,215
1.1/4"	UN8	8	1.000	105,000	65,000	105,000	65,000	58,500
1.3/8"	UN8	8	1.23	100,000	50,000	123,000	61,500	55,350
1.1/2"	UN8	8	1.49	100,000	50,000	149,200	74,600	67,140
1.5/8"	UN8	8	1.78					
1.3/4"	UN8	8	2.08					
1.7/8"	UN8	8	2.41					
2"	UN8	8	2.77					
2.1/4"	UN8	8	3.56					
2.1/2"	UN8	8	4.44					
2.3/4"	UN8	8	5.43					
3"	UN8	8	6.51					
3.1/4"	UN8	8	7.69					
3.1/2"	UN8	8	8.96					
3.3/4"	UN8	8	10.34					
4"	UN8	8	11.81					
4" to 7"								

Not listed in ASTM A 320/A 320M or ASTM A 193/A 193M

Minimum Tensile Loads displayed are Minimum Ultimate Capacities, derived from Stress Area and Minimum Tensile Strength.

Minimum Yield Loads displayed are derived from Stress Area and Minimum Tensile Strength.

Values displayed for Proof Load are derived from Stress Area and Minimum Yield Strength and are 90% of Minimum Yield Load.

Values displayed are NOT design loads, design professionals should apply appropriate safety factors.

Austenitic steels in the strain hardened (work hardened) condition may not show uniform properties in sizes over 1.1/2" in diameter.

HEAVY HEX BOLT DIMENSIONS

BREMICK

HEAVY HEX BOLTS
ASTM A307 GRADE B
ASTM A193 GRADE B7

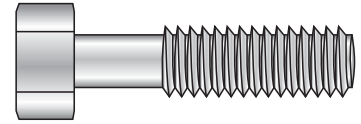

HEAVY HEX BOLT - DIMENSIONS							
Size (Inches)	Body Diameter (min) E (Inches)	Width Across Flats (min) F (Inches)	Width Across Corners (min) G (Inches)	Head Height (min) H (Inches)	Radius of Flat (min) R (Inches)	Thread Lengths for Bolt Length (L)	
						Lengths 6" and Shorter Lt (Inches)	Lengths over 6" Lt (Inches)
1/2"	0.482	0.850	0.969	0.302	0.01	1.25	1.50
5/8"	0.605	1.031	1.175	0.78	0.02	1.50	1.75
3/4"	0.729	1.212	1.383	0.455	0.02	1.75	2.00
7/8"	0.852	1.394	1.589	0.531	0.02	2.00	2.25
1"	0.976	1.575	1.796	0.591	0.03	2.25	2.50
1.1/8"	1.098	1.756	2.002	0.658	0.03	2.50	2.75
1.1/4"	1.223	1.938	2.209	0.749	0.03	3.00	3.25
1.3/8"	1.345	2.119	2.416	0.810	0.03	3.25	3.50
1.3/4"	1.716	2.662	3.035	1.054	0.04	3.75	4.00
2"	1.964	3.025	3.449	1.175	0.04	4.25	4.50
2.1/4"	2.214	3.388	3.862	1.327	0.06	4.75	5.00
2.1/2"	2.461	3.750	4.275	1.479	0.06	5.25	5.50
2.3/4"	2.711	4.112	4.688	1.632	0.06	5.75	6.00
3"	2.961	4.475	5.102	1.815	0.06	6.25	6.50

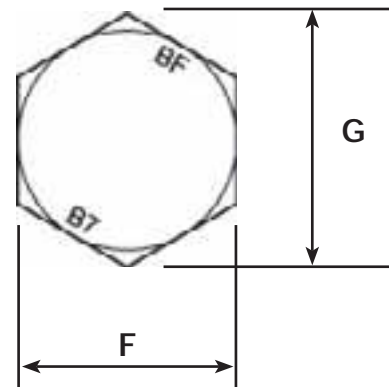
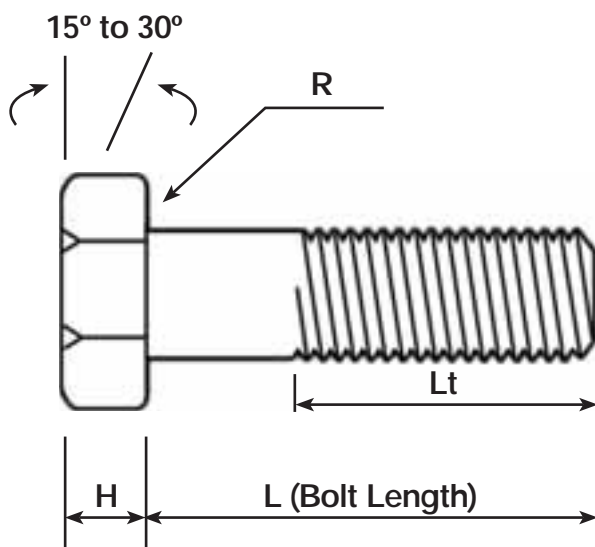

Note: Dimensions shown are minimum dimensions, for further information please refer to ANSI B18.2.1

Chemical composition and mechanical properties

Hexagonal Hex Nuts - Grades 2H, 2HM, 4L, 7, & 7M

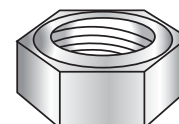

ASTM Heavy Hex Nut Grade	2H	2HM	4L	7	7M
Marking Symbol	BF 2H	BF 2HM	BF 4L	BF 7	BF 7M
Service Temperature	0°C to 450°C	-30°C to 400°C	-100°C to 520°C	-100°C to 565°C	-73°C to -30°C
ASTM Specification	ASTM A194/A194M	ASTM A194/A194M	ASTM A194/A194M	ASTM A194/A194M	ASTM A194/A194M
AISI Material	Carbon Steel	Carbon Steel	Carbon Molybdenum	4140	4140
Style	Heavy Hex	Heavy Hex	Heavy Hex	Heavy Hex	Heavy Hex

Chemical Composition %

Carbon	0.40 min	0.40 min	0.40-0.50	0.37-0.49	0.37-0.49
Manganese	1.00 max	1.00 max	0.70-0.90	0.65-1.10	0.65-1.10
Phosphorous	0.040 max	0.040 max	0.035 max	0.035 max	0.035 max
Sulphur	0.050 max	0.050 max	0.040 max	0.040 max	0.040 max
Silicon	0.40 max	0.40 max	0.15-0.35	0.15-0.35	0.15-0.35
Chromium	-	-	-	0.75-1.20	0.75-1.20
Molybdenum	-	-	0.20-0.30	0.15-0.25	0.15-0.25
Vanadium	-	-	-	-	-
Nickel	-	-	-	-	-

Mechanical Properties

Diameter	1 1/2" and Under	All Diameters	All Diameters	1 1/2" and Under	All Diameters
Brinell Hardness (Completed Nut)	248-327 HB (24-35 HRB)	159-235 HB (84-99 HRB)	248-327 HB (24-35 HRC)	248-327 HB (24-35 HRC)	159-235 HB (84-99 HRB)
Brinell Hardness (After Treatment)	179 HB min (89 HRB)	159 HB min (84 HRB)	201 HB min (94 HRB)	201 HB min (94 HRB)	159 HB min (84 HRB)
Diameter	Over 1 1/2"			Over 1 1/2"	
Brinell Hardness (Completed Nut)	212-327 HB (35 HRC max 95 HRC min)	-	-	248-327 HB	-
Brinell Hardness (After Treatment)	147 HB min (79 HRB)	-	-	201 HB min (94 HRB)	-

Note: Other Grades of Studbolts and Nuts may be manufactured to order.

Please refer to relevant standards for more detailed information.

Service Temperatures refer to actual metal temperatures.

Brinell Hardness (After Treatment) refers to sample nuts that are tested in accordance with ASTM A194/A194M-09 section 8.1.5

Chemical composition and mechanical properties

Hexagonal Hex Nuts - Grades 8, 8M, 8T & 8C

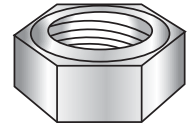

ASTM Heavy Hex Nut Grade	8	8M	8T	8C
Marking Symbol	BF 8	BF 8M	BF 8T	BF 8C
Service Temperature	-250°C to 575°C	-250°C to 600°C	-250°C to 575°C	-150°C to 575°C
ASTM Specification	ASTM A194/A194M	ASTM A194/A194M	ASTM A194/A194M	ASTM A194/A194M
AISI Material	Type 304 Stainless Steel	Type 316 Stainless Steel	Type 321 Stainless Steel	Type 347 Stainless Steel
Style	Heavy Hex	Heavy Hex	Heavy Hex	Heavy Hex

Chemical Composition %

Carbon	0.08 max	0.08 max	0.08 max	0.08 max
Manganese	2.00 max	2.00 max	2.00 max	2.00 max
Phosphorous	0.045 max	0.045 max	0.045 max	0.045 max
Sulphur	0.03 max	0.03 max	0.03 max	0.03 max
Silicon	1.00 max	1.00 max	1.00 max	1.00 max
Chromium	18.0-20.0	16.0-18.0	17.0-19.0	17.0-19.0
Nickel	8.0-11.0	10.0-14.0	9.0-12.0	9.0-12.0
Molybdenum	-	2.00-3.00	-	-
Titanium	-	-	5x(C+N) min-0.70 max	-
Columbium & Tantalum	-	-	-	10x carbon content min
Nitrogen	-	-	0.10% max	-
Vanadium	-	-	-	-

Mechanical Properties

Diameter	1 1/2" and Under	1 1/2" and Under	All Diameters	All Diameters
Brinell Hardness (Completed Nut)	126-300 HB (60 HRB-32 HRC)	126-300 HB (60 HRB-32 HRC)	126-300 HB (60 HRB-32 HRC)	126-300 HB (60 HRB-32 HRC)
Brinell Hardness (After Treatment)	-	-	-	-

Diameter	Over 1 1/2"	Over 1 1/2"	-	-
Brinell Hardness (Completed Nut)	126-300 HB (60 HRB-32 HRC)	126-300 HB (60 HRB-32 HRC)	-	-
Brinell Hardness (After Treatment)	-	-	-	-

Note: Other Grades of Studbolts and Nuts may be manufactured to order.

Please refer to relevant standards for more detailed information.

Service Temperatures refer to actual metal temperatures.

Brinell Hardness (After Treatment) refers to sample nuts that are tested in accordance with ASTM A194/A194M-09 section 8.1.5

Mechanical properties of heavy hex nuts

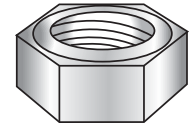

MECHANICAL PROPERTIES - Grades 2H, 3, 4, 4L, 7, 7L, 16
High Pressure or High Temperature Service
ASTM A194 / A194M

HEAVY HEX NUTS - MECHANICAL PROPERTIES						
Nominal Size (D)	Thread	TPI (n)	Stress Area (As)	Proof Stress (f)	Proof Load (PL)	
Inches			in ²	psi	lbf	
3/8"	UNC	16	0.0775	175,000	13,560	
1/2"	UNC	13	0.142	175,000	24,830	
5/8"	UNC	11	0.226	175,000	39,550	
3/4"	UNC	10	0.334	175,000	58,450	
7/8"	UNC	9	0.462	175,000	80,850	
1"	UNC	8	0.606	175,000	106,000	
1.1/8"	UN8	8	0.790	175,000	138,200	
1.1/4"	UN8	8	1.000	175,000	175,000	
1.3/8"	UN8	8	1.23	175,000	215,800	
1.1/2"	UN8	8	1.49	175,000	261,100	
1.5/8"	UN8	8	1.78	175,000	311,500	
1.3/4"	UN8	8	2.08	175,000	364,000	
1.7/8"	UN8	8	2.41	175,000	421,800	
2"	UN8	8	2.77	175,000	484,800	
2.1/4"	UN8	8	3.56	175,000	623,000	
2.1/2"	UN8	8	4.44	175,000	777,000	
2.3/4"	UN8	8	5.43	175,000	950,250	
3"	UN8	8	6.51			Not listed in ASTM A 194/A 194M
3.1/4"	UN8	8	7.69			
3.1/2"	UN8	8	8.96			
3.3/4"	UN8	8	10.34			
4"	UN8	8	11.81			
4" to 7"						

Values for proof stresses for diameters larger than 2.3/4" are not supported by ASTM A194/A 194M
 Proof loads for larger nuts shall be agreed upon prior to manufacturing.

MECHANICAL PROPERTIES



Mechanical properties of heavy hex nuts

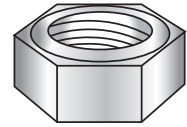

MECHANICAL PROPERTIES - GRADE 2HM, 2, 6, 6F & 7M

Low Pressure or Low Temperature Service

ASTM A194 / A194M

HEAVY HEX NUTS - MECHANICAL PROPERTIES					
Nominal Size (D)	Thread	TPI (n)	Stress Area (As)	Proof Stress (f)	Proof Load (PL)
Inches			in ²	psi	lbf
3/8"	UNC	16	0.0775	150,000	11,620
1/2"	UNC	13	0.142	150,000	21,280
5/8"	UNC	11	0.226	150,000	33,900
3/4"	UNC	10	0.334	150,000	50,100
7/8"	UNC	9	0.462	150,000	69,300
1"	UNC	8	0.606	150,000	90,900
1.1/8"	UN8	8	0.790	150,000	118,500
1.1/4"	UN8	8	1.000	150,000	150,000
1.3/8"	UN8	8	1.23	150,000	185,000
1.1/2"	UN8	8	1.49	150,000	223,800
1.5/8"	UN8	8	1.78	150,000	267,000
1.3/4"	UN8	8	2.08	150,000	312,000
1.7/8"	UN8	8	2.41	150,000	361,500
2"	UN8	8	2.77	150,000	415,500
2.1/4"	UN8	8	3.56	150,000	534,000
2.1/2"	UN8	8	4.44	150,000	666,000
2.3/4"	UN8	8	5.43	150,000	814,500
3"	UN8	8	6.51		
3.1/4"	UN8	8	7.69		
3.1/2"	UN8	8	8.96		
3.3/4"	UN8	8	10.34		
4"	UN8	8	11.81		
4" to 7"					

Not listed in ASTM A 194/A 194M

Values for proof stresses for diameters larger than 2.3/4" are not supported by ASTM A194/A 194M
Proof loads for larger nuts shall be agreed upon prior to manufacturing.

Mechanical properties of heavy hex nuts

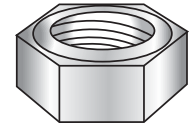

MECHANICAL PROPERTIES - Grades 8, 8T, 8C, 9C & 9CA
High Pressure or High Temperature Service
ASTM A194 / A194M

HEAVY HEX NUTS - MECHANICAL PROPERTIES						
Nominal Size (D)	Thread	TPI (n)	Stress Area (As)	Proof Stress (f)	Proof Load (PL)	
Inches			in ²	psi	lbf	
3/8"	UNC	16	0.0775	80,000	6,200	
1/2"	UNC	13	0.142	80,000	11,350	
5/8"	UNC	11	0.226	80,000	18,080	
3/4"	UNC	10	0.334	80,000	26,720	
7/8"	UNC	9	0.462	80,000	36,960	
1"	UNC	8	0.606	80,000	48,480	
1.1/8"	UN8	8	0.790	80,000	63,200	
1.1/4"	UN8	8	1.000	80,000	80,000	
1.3/8"	UN8	8	1.23	80,000	98,640	
1.1/2"	UN8	8	1.49	80,000	119,360	
1.5/8"	UN8	8	1.78			Not listed in ASTM A 194/A 194M
1.3/4"	UN8	8	2.08			
1.7/8"	UN8	8	2.41			
2"	UN8	8	2.77			
2.1/4"	UN8	8	3.56			
2.1/2"	UN8	8	4.44			
2.3/4"	UN8	8	5.43			
3"	UN8	8	6.51			
3.1/4"	UN8	8	7.69			
3.1/2"	UN8	8	8.96			
3.3/4"	UN8	8	10.34			
4"	UN8	8	11.81			
4" to 7"						

Values for proof stresses for diameters larger than 1.1/2" are not supported by ASTM A194/A 194M
 Proof loads for larger nuts shall be agreed upon prior to manufacturing.

MECHANICAL PROPERTIES



Mechanical properties of heavy hex nuts

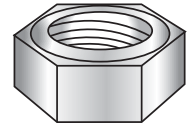

MECHANICAL PROPERTIES - GRADE 8M
High Pressure or High Temperature Service
ASTM A194 / A194M

HEAVY HEX NUTS - MECHANICAL PROPERTIES					
Nominal Size (D)	Thread	TPI (n)	Stress Area (As)	Proof Stress (f)	Proof Load (PL)
Inches			in ²	psi	lbf
3/8"	UNC	16	0.0775	110,000	8,510
1/2"	UNC	13	0.142	110,000	15,610
5/8"	UNC	11	0.226	110,000	24,860
3/4"	UNC	10	0.334	110,000	36,740
7/8"	UNC	9	0.462	100,000	46,200
1"	UNC	8	0.606	100,000	60,600
1.1/8"	UN8	8	0.790	95,000	75,050
1.1/4"	UN8	8	1.000	95,000	95,000
1.3/8"	UN8	8	1.23	90,000	110,970
1.1/2"	UN8	8	1.49	90,000	134,280
1.5/8"	UN8	8	1.78		
1.3/4"	UN8	8	2.08		
1.7/8"	UN8	8	2.41		
2"	UN8	8	2.77		
2.1/4"	UN8	8	3.56		
2.1/2"	UN8	8	4.44		
2.3/4"	UN8	8	5.43		
3"	UN8	8	6.51		
3.1/4"	UN8	8	7.69		
3.1/2"	UN8	8	8.96		
3.3/4"	UN8	8	10.34		
4"	UN8	8	11.81		
4" to 7"					

Not listed in ASTM A 194/A 194M

Values for proof stresses for diameters larger than 1.1/2" are not supported by ASTM A194/A 194M
 Proof loads for larger nuts shall be agreed upon prior to manufacturing.

HEAVY SERIES HEX NUT DIMENSIONS



BF
B7

ANSI B18.2.2

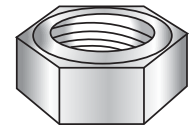
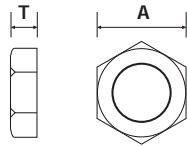

Thread Diameter	TPI	Dimension A		Dimension T	
		Min	Max	Min	Max
3/8"	16	0.669	0.688	0.341	0.377
1/2"	13	0.850	0.875	0.464	0.504
5/8"	11	1.031	1.062	0.687	0.631
3/4"	10	1.212	1.250	0.71	0.758
7/8"	9	1.394	1.438	0.833	0.885
1"	8	1.575	1.625	0.956	1.012
1.1/8"	8	1.756	1.812	1.079	1.139
1.1/4"	8	1.938	2.000	1.187	1.251
1.3/8"	8	2.119	2.188	1.31	1.378
1.1/2"	8	2.300	2.375	1.433	1.505
1.5/8"	8	2.481	2.562	1.556	1.632
1.3/4"	8	2.662	2.750	1.679	1.759
1.7/8"	8	2.844	2.938	1.802	1.886
2"	8	3.025	3.125	1.925	2.013
1.1/4"	8	3.388	3.500	2.155	2.251
2.1/2"	8	3.750	3.875	2.401	2.505
2.3/4"	8	4.223	4.250	2.647	2.759
3"	8	4.475	4.625	2.893	3.013
3.1/4"	8	4.838	5.000	3.124	3.252
3.1/2"	8	5.200	5.375	3.37	3.506
4"	8	5.925	6.125	3.862	4.014

HEAVY SERIES HEX NUT WEIGHT LIST

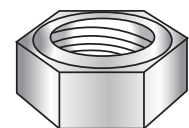

Diameter	3/8"	7/16"	1/2"	9/16"	5/8"	3/4"	7/8"	1"	1.1/8"	1.1/4"	1.3/8"
Kg per 100	1.4	1.9	3.0	3.7	5.4	8.8	13.5	19.3	26.9	35.7	46.3
Diameter	1.1/2"	1.5/8"	1.3/4"	1.7/8"	2"	2.1/4"	2.1/2"	2.3/4"	3"	3.1/2"	
Kg per 100	59.4	73.5	92.5	109.3	135.6	190.1	255.8	334.8	430.9	692.2	

BREMICK HEAVY HEX NUT - TECHNICAL INFORMATION

BREMSTUD WEIGHT LIST

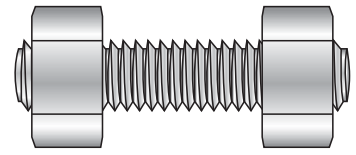

Stud Bolts complete with 2 nuts - Kg per 100

Stud Length (mm)	Diameter											
	3/8"	7/16"	1/2"	9/16"	5/8"	3/4"	7/8"	1"	1.1/8"	1.1/4"	1.3/8"	
50	5.3	7.2	10.4	13.6	18.0	28.1						
60	5.7	7.8	11.2	14.7	19.2	29.9						
65	5.9	8.1	11.6	15.3	19.9	30.9						
70	6.2	8.4	12.0	15.8	20.5	31.8						
75	6.4	8.7	12.4	16.3	21.1	32.7	47.8	65.9	88.9	115.5	146.8	
80	6.6	9.0	12.8	16.9	21.8	33.7	49.0	67.6	91.1	118.2	150.1	
85	6.8	9.3	13.2	17.4	22.4	34.6	50.3	69.3	93.2	120.9	153.4	
90	7.0	9.6	13.6	18.0	23.0	35.5	51.6	70.9	95.4	123.6	156.7	
95	7.2	9.9	14.0	18.5	23.7	36.4	52.8	72.6	97.5	126.3	160.0	
100	7.5	10.2	14.4	19.1	24.3	37.4	54.1	74.3	99.7	129.0	163.3	
105	7.7	10.5	14.8	19.6	24.9	38.3	55.4	75.9	101.8	131.7	166.6	
110	7.9	10.8	15.2	20.2	25.6	39.2	56.6	77.6	104.0	134.4	169.9	
115	8.1	11.1	15.5	20.7	26.2	40.2	57.9	79.3	106.1	137.1	173.3	
120	8.3	11.3	15.9	21.3	26.8	41.1	59.2	81.0	108.3	139.8	176.6	
125	8.5	11.6	16.3	21.8	27.4	42.0	60.4	82.6	110.4	142.5	179.9	
130	8.8	11.9	16.7	22.4	28.1	42.9	61.7	84.3	112.6	145.2	183.2	
135	9.0	12.2	17.1	22.9	28.7	43.9	63.0	86.0	114.7	147.9	186.5	
140	9.2	12.5	17.5	23.4	29.3	44.8	64.3	87.6	116.9	150.6	189.8	
145	9.4	12.8	17.9	24.0	30.0	45.7	65.5	89.3	119.0	153.3	193.1	
150	9.6	13.1	18.3	24.5	30.6	46.7	66.8	91.0	121.2	155.9	196.4	
160		13.7	19.1	25.6	31.9	48.5	69.3	94.3	125.5	161.3	203.0	
165		14.0	19.5	26.2	32.5	49.4	70.6	96.0	127.6	164.0	206.3	
170		14.3	19.9	26.7	33.1	50.4	71.9	97.6	129.8	166.7	209.6	
180		14.9	20.7	27.8	34.4	52.2	74.4	101.0	134.1	172.1	216.3	
185			21.1	28.4	35.0	53.2	75.7	102.6	136.2	174.8	219.6	
190			21.5	28.9	35.6	54.1	76.9	104.3	138.4	177.5	222.9	
195			21.8	29.4	36.3	55.0	78.2	106.0	140.5	180.2	226.2	
200			22.2	30.0	36.9	55.9	79.5	107.7	142.7	182.9	229.5	
210			23.0	31.1	38.2	57.8	82.0	111.0	146.9	188.3	236.1	
215			23.4	31.6	38.8	58.7	83.3	112.7	149.1	191.0	239.4	
220			23.8	32.2	39.4	59.6	84.6	114.3	151.2	193.7	242.7	
230			24.6	33.3	40.7	61.5	87.1	117.7	155.5	199.1	249.3	
235			25.0	33.8	41.3	62.4	88.4	119.3	157.7	201.8	252.6	
240			25.4	34.4	42.0	63.4	89.6	121.0	159.8	204.5	255.9	
250			26.2	35.4	43.2	65.2	92.2	124.3	164.1	209.9	262.6	
255			26.6	36.0	43.8	66.1	93.4	126.0	166.3	212.6	265.9	
260			27.0	36.5	44.5	67.1	94.7	127.7	168.4	215.3	269.2	
265			27.4	37.1	45.1	68.0	96.0	129.3	170.6	217.9	272.5	
275			28.1	38.2	46.4	69.9	98.5	132.7	174.9	223.3	279.1	
280			28.5	38.7	47.0	70.8	99.8	134.4	177.0	226.0	282.4	
285			28.9	39.3	47.6	71.7	101.1	136.0	179.2	228.7	285.7	
290			29.3	39.8	48.3	72.6	102.3	137.7	181.3	231.4	289.0	
300			30.1	40.9	49.5	74.5	104.9	141.0	185.6	236.8	295.6	

CONTINUED OVER PAGE ►

BREMSTUD WEIGHT LIST



BF
B7

CONTINUED

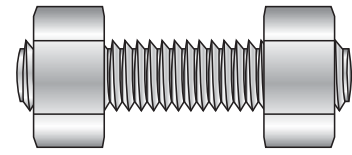

Stud Bolts complete with 2 nuts - Kg per 100

Stud Length (mm)	Diameter									
	1.1/2"	1.5/8"	1.3/4"	1.7/8"	2"	2.1/4"	2.1/2"	2.3/4"	3"	3.1/2"
50										
60										
65										
70										
75										
80										
85										
90										
95										
100										
105										
110	212.1									
115	216.1									
120	220.1									
125	224.1									
130	228.1									
135	232.1									
140	236.1									
145	240.1									
150	244.0	294.9	358.3							
160	252.0	304.3	369.3							
165	256.0	309.0	374.8							
170	260.0	313.8	380.3	443.8						
180	268.0	323.2	391.4	456.5						
185	272.0	327.9	396.9	462.9						
190	275.9	332.6	402.4	469.3						
195	279.9	337.3	407.9	475.6						
200	283.9	342.0	413.4	482.0						
210	291.9	351.5	424.5	494.7						
215	295.9	356.2	430.0	501.1						
220	299.9	360.9	435.5	507.4	602.4					
230	307.8	370.3	446.5	520.1	617.0	822.1				
235	311.8	375.0	452.1	526.5	624.3	831.4				
240	315.8	379.7	457.6	532.9	631.6	840.7				
250	323.8	389.2	468.6	545.6	646.2	859.4				
255	327.8	393.9	474.1	551.9	653.5	868.7				
260	331.8	398.6	479.6	558.3	660.8	878.0				
265	335.8	403.3	485.2	564.7	668.1	887.3				
275	343.7	412.7	496.2	577.4	682.7	906.0				
280	347.7	417.4	501.7	583.8	690.0	915.3				
285	351.7	422.1	507.2	590.1	697.3	924.6				
290	355.7	426.8	512.7	596.5	704.6	934.0				
300	363.7	436.3	523.8	609.2	719.2	952.6				

CONTINUED OVER PAGE ►

BREMICK BREMSTUD WEIGHT LIST

BREMSTUD WEIGHT LIST



CONTINUED

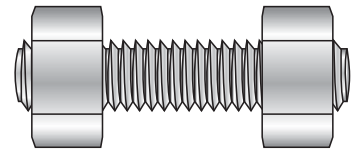

Stud Bolts complete with 2 nuts - Kg per 100

Stud Length (mm)	Diameter											
	3/8"	7/16"	1/2"	9/16"	5/8"	3/4"	7/8"	1"	1.1/8"	1.1/4"	1.3/8"	
305			30.5	41.4	50.1	75.4	106.1	142.7	187.8	239.5	298.9	
310			30.9	42.0	50.8	76.4	107.4	144.4	189.9	242.2	302.3	
320			31.7	43.1	52.0	78.2	109.9	147.7	194.2	247.6	308.9	
325			32.1	43.6	52.7	79.1	111.2	149.4	196.4	250.3	312.2	
330			32.5	44.2	53.3	80.1	112.5	151.0	198.5	253.0	315.5	
335			32.9	44.7	53.9	81.0	113.8	152.7	200.7	255.7	318.8	
345			33.7	45.8	55.2	82.9	116.3	156.1	205.0	261.1	325.4	
350			34.1	46.4	55.8	83.8	117.6	157.7	207.1	263.8	328.7	
355						84.7	118.8	159.4	209.3	266.5	332.0	
360						85.6	120.1	161.1	211.4	269.2	335.3	
370						87.5	122.6	164.4	215.7	274.6	342.0	
375						88.4	123.9	166.1	217.9	277.3	345.3	
380						89.4	125.2	167.7	220.0	279.9	348.6	
385						90.3	126.4	169.4	222.1	282.6	351.9	
395						92.1	129.0	172.7	226.4	288.0	358.5	
400						93.1	130.3	174.4	228.6	290.7	361.8	
405						94.0	131.5	176.1	230.7	293.4	365.1	
415						95.9	134.1	179.4	235.0	298.8	371.7	
420						96.8	135.3	181.1	237.2	301.5	375.0	
425						97.7	136.6	182.8	239.3	304.2	378.3	
430						98.6	137.9	184.4	241.5	306.9	381.6	
440						100.5	140.4	187.8	245.8	312.3	388.3	
445						101.4	141.7	189.4	247.9	315.0	391.6	
450						102.4	142.9	191.1	250.1	317.7	394.9	
455						103.3	144.2	192.8	252.2	320.4	398.2	
465						105.1	146.7	196.1	256.5	325.8	404.8	
470						106.1	148.0	197.8	258.7	328.5	408.1	
475						107.0	149.3	199.4	260.8	331.2	411.4	
485						108.9	151.8	202.8	265.1	336.6	418.0	
490						109.8	153.1	204.4	267.3	339.3	421.3	
495						110.7	154.4	206.1	269.4	342.0	424.6	
500						111.6	155.6	207.8	271.6	344.6	428.0	
510						113.5	158.2	211.1	275.9	350.0	434.6	
530												
540												
560												
580												
600												
620												
640												
660												
680												
700												

CONTINUED OVER PAGE ►

BREMSTUD WEIGHT LIST



BF
B7

CONTINUED

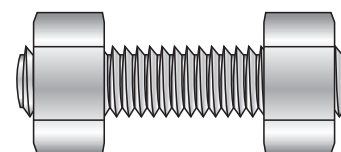

Stud Bolts complete with 2 nuts - Kg per 100

Stud Length (mm)	Diameter									
	1.1/2"	1.5/8"	1.3/4"	1.7/8"	2"	2.1/4"	2.1/2"	2.3/4"	3"	3.1/2"
305	367.7	441.0	529.3	615.6	726.5	961.9				
310	371.6	445.7	534.8	621.9	733.8	971.3				
320	379.6	455.1	545.8	634.6	748.3	989.9	1270.5			
325	383.6	459.8	551.3	641.0	755.6	999.2	1282.1			
330	387.6	464.5	556.9	647.4	762.9	1008.5	1293.7			
335	391.6	469.3	562.4	653.7	770.2	1017.9	1305.3			
345	399.6	478.7	573.4	666.4	784.8	1036.5	1328.5			
350	403.5	483.4	578.9	672.8	792.1	1045.8	1340.1			
355	407.5	488.1	584.4	679.2	799.4	1055.2	1351.7			
360	411.5	492.8	590.0	685.5	806.7	1064.5	1363.3	1706.7		
370	419.5	502.2	601.0	698.2	821.3	1083.1	1386.5	1735.0		
375	423.5	506.9	606.5	704.6	828.6	1092.5	1398.1	1749.1		
380	427.5	511.7	612.0	711.0	835.9	1101.8	1409.7	1763.2	2168.2	
385	431.5	516.4	617.5	717.3	843.2	1111.1	1421.3	1777.3	2185.1	
395	439.4	525.8	628.6	730.1	857.8	1129.8	1444.5	1805.6	2218.9	
400	443.4	530.5	634.1	736.4	865.1	1139.1	1456.1	1819.7	2235.8	
405	447.4	535.2	639.6	742.8	872.4	1148.4	1467.7	1833.9	2252.6	
415	455.4	544.6	650.6	755.5	887.0	1167.1	1490.9	1862.1	2286.4	
420	459.4	549.4	656.2	761.9	894.3	1176.4	1502.5	1876.3	2303.3	
425	463.3	554.1	661.7	768.2	901.5	1185.7	1514.1	1890.4	2320.2	
430	467.3	558.8	667.2	774.6	908.8	1195.0	1525.7	1904.5	2337.0	
440	475.3	568.2	678.2	787.3	923.4	1213.7	1548.9	1932.8	2370.8	3456.2
445	479.3	572.9	683.7	793.7	930.7	1223.0	1560.5	1946.9	2387.7	3479.4
450	483.3	577.6	689.3	800.0	938.0	1232.3	1572.1	1961.0	2404.6	3502.5
455	487.3	582.3	694.8	806.4	945.3	1241.6	1583.7	1975.2	2421.4	3525.7
465	495.2	591.8	705.8	819.1	959.9	1260.3	1606.9	2003.4	2455.2	3572.1
470	499.2	596.5	711.3	825.5	967.2	1269.6	1618.5	2017.6	2472.1	3595.2
475	503.2	601.2	716.8	831.8	974.5	1278.9	1630.1	2031.7	2488.9	3618.4
485	511.2	610.6	727.9	844.5	989.1	1297.6	1653.3	2060.0	2522.7	3664.8
490	515.2	615.3	733.4	850.9	996.4	1306.9	1664.9	2074.1	2539.6	3687.9
495	519.2	620.0	738.9	857.3	1003.7	1316.2	1676.5	2088.2	2556.5	3711.1
500	523.2	624.7	744.4	863.6	1011.0	1325.6	1688.1	2102.4	2573.3	3734.3
510	531.1	634.2	755.5	876.3	1025.6	1344.2	1711.3	2130.6	2607.1	3780.6
530		653.0	777.5	901.8	1054.7	1381.5	1757.8	2187.1	2674.6	3873.3
540		662.4	788.6	914.5	1069.3	1400.2	1781.0	2215.4	2708.4	3919.7
560		681.3	810.6	940.0	1098.5	1437.4	1827.4	2271.9	2775.9	4012.4
580				965.4	1127.7	1474.7	1873.8	2328.4	2843.4	4105.1
600				990.8	1156.9	1512.0	1920.2	2385.0	2910.9	4197.8
620				1016.3	1186.1	1549.3	1966.6	2441.5	2978.4	4290.5
640					1215.2	1586.6	2013.0	2498.0	3046.0	4383.2
660					1244.4	1623.9	2059.4	2554.5	3113.5	4475.9
680						1661.2	2105.8	2611.1	3181.0	4568.6
700						1698.5	2152.2	2667.6	3248.5	4661.3

BREMICK BREMSTUD WEIGHT LIST

LENGTH CONVERSIONS			
IMPERIAL UNIT	METRIC UNIT	IMPERIAL TO METRIC	METRIC TO IMPERIAL
inch	millimetre	1 in = 25.40 mm	1 mm = 0.03937 in
foot	millimetre	1 ft = 304.8 mm	1mm = 0.003281 ft
foot	metre	1 ft = 0.3048 m	1 m = 3.281 ft
yard	metre	1 yd = 0.9144 m	1 m = 1.094 yd
mile	metre	1 mile = 1609 m	1 m = 0.0006214 mile
mile	kilometre	1 mile = 1.609 km	1 km = 0.6214 mile

AREA CONVERSIONS			
IMPERIAL UNIT	METRIC UNIT	IMPERIAL TO METRIC	METRIC TO IMPERIAL
square inch	square millimetre	1 in ² = 645.2 mm ²	1 mm ² = 0.001550 in ²
square foot	square millimetre	1 ft ² = 92900 mm ²	1 mm ² = 0.00001076 ft ²
square foot	square metre	1 ft ² = 0.9290 m ²	1 m ² = 10.76 ft ²
square yard	square metre	1 yd ² = 0.8361 m ²	1 m ² = 1.196 yd ²

VOLUME CONVERSIONS			
IMPERIAL UNIT	METRIC UNIT	IMPERIAL TO METRIC	METRIC TO IMPERIAL
cubic inch	cubic millimetre	1 in ³ = 16387 mm ³	1 mm ³ = 0.00006102 in ³
cubic foot	cubic metre	1 ft ³ = 0.02832 m ³	1 m ³ = 35.31 ft ³
cubic yard	cubic metre	1 yd ³ = 0.7646 m ³	1 m ³ = 1.308 yd ³

LIQUID VOLUME CONVERSIONS			
IMPERIAL UNIT	METRIC UNIT	IMPERIAL TO METRIC	METRIC TO IMPERIAL
gallon (UK)	litre	1 gal = 4.546 Litre	1 litre = 0.2200 gal (UK)

MASS CONVERSIONS			
IMPERIAL UNIT	METRIC UNIT	IMPERIAL TO METRIC	METRIC TO IMPERIAL
ounce	gram	1 oz = 28.35 g	1 g = 0.03527 oz
pound	kilogram	1 lb = 0.4536 kg	1 kg = 2.205 lb
hundredweight	kilogram	1 cwt = 50.80 kg	1 kg = 0.01968 cwt
ton	kilogram	1 ton = 1016 kg	1 kg = 0.0009842 ton
ton	tonne	1 ton = 1.016 tonne	1 tonne = 0.9842 ton
short ton (US)	tonne	1 short ton = 0.9072 tonne	1 tonne = 1.102 short ton

MASS PER UNIT LENGTH CONVERSIONS			
IMPERIAL UNIT	METRIC UNIT	IMPERIAL TO METRIC	METRIC TO IMPERIAL
pound per foot	kilogram per metre	1 lb/ft = 1.488 kg/m	1 kg/m = 0.672 lb/ft
pound per yard	kilogram per metre	1 lb/yd = 0.4961 kg/m	1 kg/m = 2.016 lb/yd

MASS PER UNIT AREA CONVERSIONS			
IMPERIAL UNIT	METRIC UNIT	IMPERIAL TO METRIC	METRIC TO IMPERIAL
pound per square inch	kilogram per square metre	1 lb/in ² = 703.1 kg/m ²	1 kg/m ² = 0.001422 lb/in ²
pound per square foot	kilogram per square metre	1 lb/ft ² = 4.882 kg/m ²	1 kg/m ² = 0.2048 lb/ft ²

MASS PER UNIT VOLUME CONVERSIONS			
IMPERIAL UNIT	METRIC UNIT	IMPERIAL TO METRIC	METRIC TO IMPERIAL
pound per cubic inch	kilogram per cubic metre	1 lb/in ³ = 27680 kg/m ³	1 kg/m ³ = 0.00003605 lb/in ³
pound per cubic foot	kilogram per cubic metre	1 lb/ft ³ = 16.02kg/m ³	1 kg/m ³ = 0.0624 lb/ft ³
pound per cubic yard	kilogram per cubic metre	1 lb/yd ³ = 0.5933 kg/m ³	1 kg/m ³ = 1.686 lb/yd ³

METRIC / IMPERIAL CONVERSION TABLES



FORCE CONVERSIONS			
IMPERIAL UNIT	METRIC UNIT	IMPERIAL TO METRIC	METRIC TO IMPERIAL
pound force	newton	1 lbf = 4.448 N	1 N = 0.2248 lbf
ton force	kilonewton	1 tonf = 9.964 kN	1 kN = 0.1004 tonf
1000 pound force	kilonewton	1 kip = 4.448 kN	1 kN = 0.2248 kip
	kilogram force-newton		1 kgf = 9.807 N
	newton		1 N = 0.1020 kgf

PRESSURE & STRESS CONVERSIONS			
IMPERIAL UNIT	METRIC UNIT	IMPERIAL TO METRIC	METRIC TO IMPERIAL
pound force per square inch	megapascal	1 lbf/in ² = 0.006895 Mpa	1 MPa = 145.0 lbf/in ²
pound force per square inch	kilopascal	1 lbf/in ² = 6.895 kPa	1 kPa = 0.1450 lbf/in ²
ton force per square inch	megapascal	1 tonf/in ² = 15.44 Mpa	1 MPa = 0.06476 tonf/in ²
1000 pound force per square inch	megapascal	1 kip/in ² = 6.895 Mpa	1 MPa = 0.1450 kip/in ²
	megapascal		1 kgf/mm ² = 9.807 MPa
	megapascal		1 MPa = 1 N/mm ²
	kilopascal		1 kPa = 0.001 N/mm ²
pound per square inch		1 psi (US) = 1 lbf/in ²	
1000 pound per square inch		1 ksi (US) = 1000 psi (US)	

MOMENT OF FORCE (TORQUE) CONVERSIONS			
IMPERIAL UNIT	METRIC UNIT	IMPERIAL TO METRIC	METRIC TO IMPERIAL
pound force inch	newton metre	1 lbf in = 0.113 Nm	1 Nm = 8.851 lbf in
pound force foot	newton metre	1 lbf ft = 1.356 Nm	1 Nm = 0.7376 lbf ft
1000 pound force inch	kilonewton metre	1 kip in = 0.113 kNm	1 kNm = 8.851 kip in
tons force foot	kilonewton metre	1 ton ft = 3.037 kNm	1 kNm = 0.3293 tonf ft
	kilogram force per metre		1 kgf m = 9.807 Nm
	newton metre		1 Nm = 0.102 kgf m

POWER CONVERSIONS			
IMPERIAL UNIT	METRIC UNIT	IMPERIAL TO METRIC	METRIC TO IMPERIAL
foot pound per second	watt	1 ft lbf/s = 1.356 W	1 W = 0.7376 ft lbs/s
horse power	watt	1 hp = 754.7 W	1 W = 0.001341 hp
British thermal units per hour	watt	1 Btu/h = 0.2931 W	1 W = 3.412 Btu/h

ENERGY CONVERSIONS			
IMPERIAL UNIT	METRIC UNIT	IMPERIAL TO METRIC	METRIC TO IMPERIAL
foot pound-force	joule	1 ft lbf = 1.356 J	1 J = 0.7376 ft lbf

VELOCITY CONVERSIONS			
IMPERIAL UNIT	METRIC UNIT	IMPERIAL TO METRIC	METRIC TO IMPERIAL
foot per second	metre per second	1 fps = 0.3048 m/s	1 m/s = 3.281 fps
mile per hour	kilometre per hour	1 mph = 1.609 km/h	1 km/h = 0.6214 mph
inch per second	millimetre per second	1 ips = 25.40 mm/s	1 mm/s = 0.03937 ips

Stud bolt assembly and tightening

Each pipeline is uniquely engineered to accommodate the fluids carried, service pressures, service temperature range, operating conditions and environmental exposure. Accordingly each bolted flange connection, for any given pipe, is by design unique in respect of the pipe flange, gasket type and bolting specifications. Generally the integrity of the flange connection is largely reliant upon attaining an even gasket seating pressure that is applied by the controlled tensioning of the stud bolts under a controlled tightening sequence.

Target Gasket Pressures

The required seating pressure is wholly dependent upon the type and the mechanical properties of the gasket used. Over tightening of the stud bolts will result in the destruction of the gasket or deformation of the pipe flanges, and under tightening may result in leakage. Design professionals and installers are advised to consult with the Gasket manufacturer prior to developing installation procedures.

Attaining Bolt Tension

Imparting bolt tension into Stud Bolts can be achieved by tightening the nut or bolt head, by attainment of bolt elongation (strain), bolt load (stress) using hydraulic tensioning devices or by the use of direct tensioning devices.

The most widely used method for flange bolting is by tightening the nut or bolt head to a predetermined 'tightening torque'.

Whilst in theory there is direct correlation between applied torque and bolt tension in practice 50% of the applied tightening torque is resisted by surface friction between the bolt/nut and the flange, a further 40% is consumed by friction of the mating threads, leaving only 10% of the applied force to develop bolt tension.

Fortunately due to controlled manufacturing tolerances of Bremick stud bolts, the application of special surface coatings to control surface lubricity, careful application of lubrication, field experience and laboratory testing, it has been possible to derive a series of "torque coefficients" (k factors), that can be applied to give approximate, yet reliable guidance for the relationship between applied torque and bolt tension.

Torque Coefficients (k factors)

The "Torque / Tightening Coefficients" table displays the "k" factors applicable to Bremick Bremstud products.

Tightening Torques

The following tables "Bolt Tension and Tightening Torques" give guidance for tightening torques required to attain Bolt Preloads of 33% and 66% of "minimum bolt yield". These values have been derived using a "k factor" of 0.2 and the values displayed are applicable to plain studs with clean, burr free threads and light oil lubrication. Tightening torque guidance for Bremstud products with other coatings and lubrication can be attained by the application of the Torque Multiplier given in the following table "Torque / Tightening Coefficients".

Torque Multiplier

For approximate tightening torques for coated Bremstuds simply apply the appropriate multiplication factor from table "Torque / Tightening Coefficients" to the Tightening Torque values given in the applicable table "Bolt Tension and Tightening Torques".

Bolt Tightening Sequences

To ensure even seating pressures and the integrity the installed pipe flange it is important to tighten the Stud Bolts in correct sequence.

The following Bolt Tightening Sequences are given for guidance and reflect current industry practice with full tightening applied over a minimum of 4 complete cycles.

Typical bolt tightening sequences for 4, 8, 12, 16, 20 and 24 bolt flanges for pipe diameters 1/2" to 24" .

4 Bolt Flanges

- PN20 (Class 150) – 1/2" to 3" pipe diameters.
- PN50 (Class 300) – 1/2" to 1. 1/2" pipe diameters.
- PN100 (Class 600) – 1/2" to 1. 1/2" pipe diameters
- PN150 (Class 900) – 1/2" to 1. 1/2" pipe diameters
- PN250 (Class 1500) – 1/2" to 1. 1/2" pipe diameters.
- PN420 (Class 2500) – 3/4" to 1. 1/8" pipe diameters

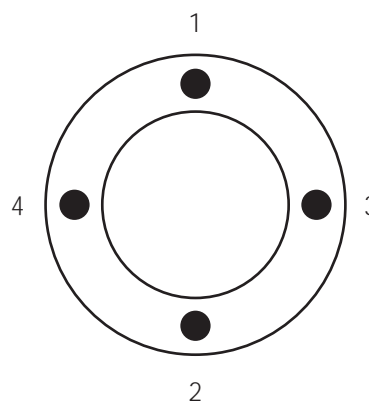

8 Bolt Flanges

- PN20 (Class 150) – 3. 1/2" to 8" pipe diameters.
- PN50 (Class 300) – 2" to 5" pipe diameters.
- PN100 (Class 600) – 2" to 5" pipe diameters
- PN150 (Class 900) – 2" to 5" pipe diameters
- PN250 (Class 1500) – 2" to 5" pipe diameters.
- PN420 (Class 2500) – 2" to 6" pipe diameters

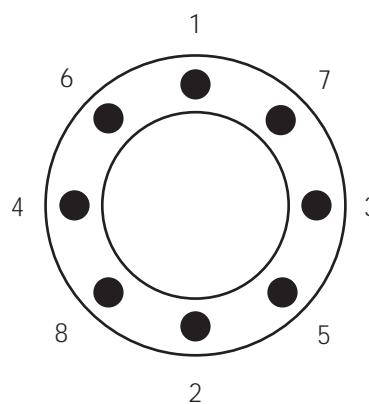

12 Bolt Flanges

- PN20 (Class 150) – 10" to 14" pipe diameters.
- PN50 (Class 300) – 6" to 8" pipe diameters.
- PN100 (Class 600) – 6" to 8" pipe diameters
- PN150 (Class 900) – 6" to 8" pipe diameters
- PN250 (Class 1500) – 6" to 10" pipe diameters.
- PN420 (Class 2500) – 8" to 12" pipe diameters

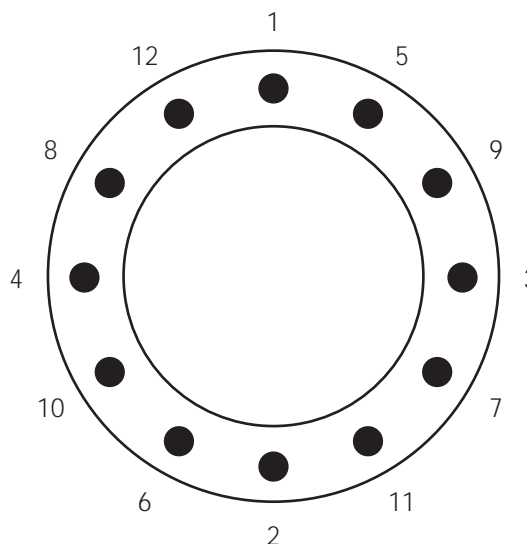

16 Bolt Flanges

PN20 (Class 150) – 16" to 18" pipe diameters.

PN50 (Class 300) – 10" to 12" pipe diameters.

PN100 (Class 600) – 10" pipe diameter

PN150 (Class 900) – 10" pipe diameter

PN250 (Class 1500) – 14" to 24" pipe diameters.

PN420 (Class 2500) – not listed in BS 3293

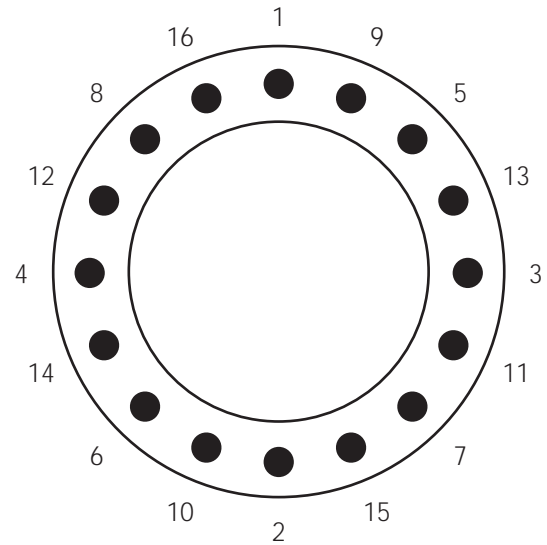
**20 Bolt Flanges**

PN20 (Class 150) – 20" to 24" pipe diameters.

PN50 (Class 300) – 14" to 16" pipe diameters.

PN100 (Class 600) – 12" to 18" pipe diameters

PN150 (Class 900) – 12" to 24" pipe diameters

PN250 (Class 1500) – not listed in BS 3293.

PN420 (Class 2500) – not listed in BS 3293

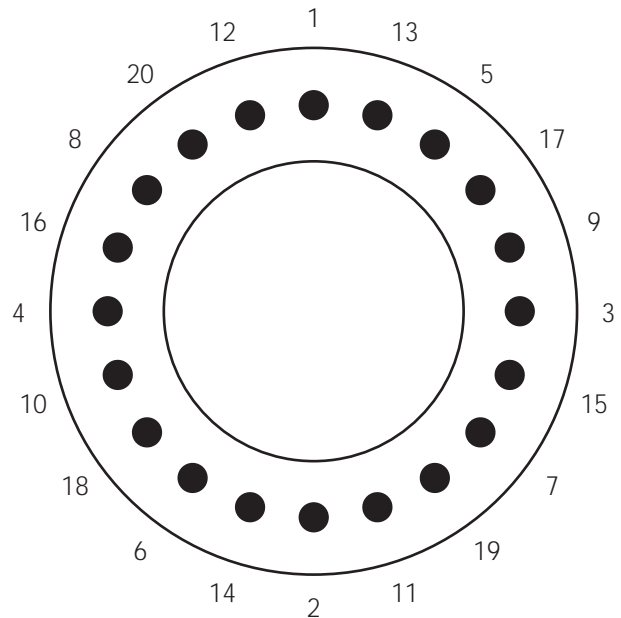
**24 Bolt Flanges**

PN20 (Class 150) – not listed in BS 3293.

PN50 (Class 300) – 18" to 24" pipe diameters.

PN100 (Class 600) – 20" to 24" pipe diameters

PN150 (Class 900) – not listed in BS 3293

PN250 (Class 1500) – not listed in BS 3293.

PN420 (Class 2500) – not listed in BS 3293

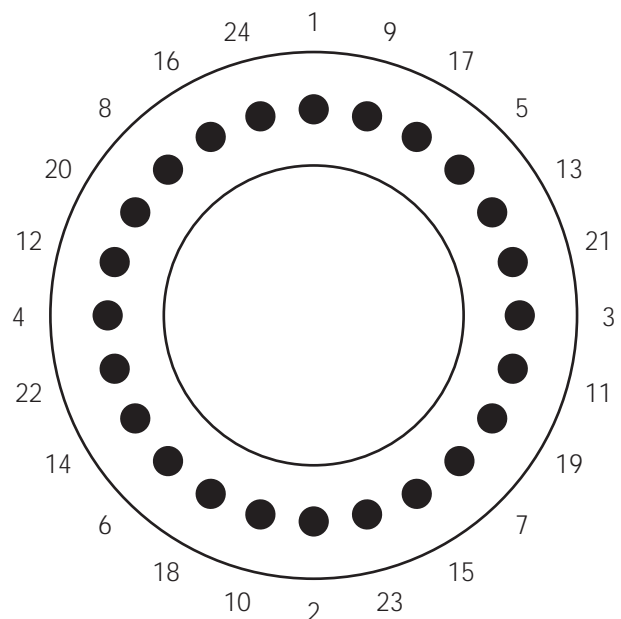

Torque / Tightening Coefficients

Stud/Bolt & Nut Coating	Lubrication	Torque Coefficient (k)	Multiplication Factor
Plain Stainless Steel	No Lubrication	0.34	1.70
Plain Stainless Steel	Lightly Oiled	0.20	1.00
Plain Carbon Steel	No Lubrication	0.25	1.25
Plain Carbon Steel	Lightly Oiled	0.20	1.00
Plain Carbon Steel	Heavily Greased	0.14	0.70
Phosphate Coated	Lightly Oiled	0.14	0.70
Zinc Plated	Degreased	0.29	1.45
Zinc Plated	No Lubrication	0.22	1.10
Zinc Plated	Lightly Oiled	0.18	0.90
Hot Dip Galvanised	Degreased	0.38	1.90
Hot Dip Galvanised	No Lubrication	0.25	1.25
Hot Dip Galvanised	Lightly Oiled	0.22	1.10
Mechanically Galvanised	No Lubrication	0.24	1.20
Mechanically Galvanised	Lightly Oiled	0.23	1.15
Cadium Plated	No Lubrication	0.17	0.85
Cadium Plated	Lightly Oiled	0.14	0.70
Molykote1PX1	No Lubrication	0.18	0.90
Inorganic Silicate (IOZ)	No Lubrication	0.17	0.85
Xylan	No Lubrication	0.10	0.50
PTFE Coated	No Lubrication	0.10	0.50
Flourobond 20	No Lubrication	0.10	0.50
Flouropolymer (Bullet Coat)	No Lubrication	0.10	0.50
Bremkote - EZN	No Lubrication	0.16	0.80
Bremkote - ZTX	No Lubrication	0.10	0.50
Bremkote - CDX	No Lubrication	0.10	0.50
Bremkote - ZNX	No Lubrication	0.10	0.50
Bremkote - EZP	No Lubrication	0.10	0.50

k factors

The above table "Torque / Tightening Coefficients" displays the relative "Torque Coefficients" (k factors) for plain, lubricated and coated stud bolt / nut products manufactured by Bremick Fasteners. These "k factors" may be used when deriving approximate tightening torques for the installation of stud bolts.

Please note: To avoid possible damage to either pipe flanges or gaskets the user is advised to seek advice from the respective pipe and gasket supplier to ensure recommended seating pressures are not exceeded.

Multiplication factors

The approximate "Tightening Torque" values displayed in the tables "Bolt Tension and Tightening Torques" gives tightening guidance for plain, lightly oiled stud bolt and nuts with a "k factor" of 0.20.

The above table "Torque / Tightening Coefficients" displays "multiplication factors" for various plain, lubricated and coated stud bolt / nut products manufactured by Bremick Fasteners. These "multiplication factors" may be applied to the "Tightening Torque" values displayed in the tables "Bolt Tension and Tightening Torques" to give approximate tightening torques for Stud bolt /nut products.

Please note: To avoid possible damage to either pipe flanges or gaskets the user is advised to seek advice from the respective pipe and gasket supplier to ensure recommended seating pressures are not exceeded.

Installation guidance for Stud Bolts and Hex Head Bolts

MECHANICAL PROPERTIES - B7

High Temperature

ASTM A 193/A 193M

BOLT TENSION AND TIGHTENING TORQUES								
Stud Bolt Properties				For Bolt Preload of 33% of Minimum Yield		For Bolt Preload of 66% of Minimum Yield		
Nominal Size	Thread	TPI	Stress Area	Minimum Yield Load	Tightening Torque	Bolt Preload (Bolt Tension)	Tightening Torque	Bolt Preload (Bolt Tension)
Inches			in ²	lbf	ft.lbs	lbf	ft.lbs	lbf
3/8"	UNC	16	0.0775	8,138	17	2,685	34	5,371
1/2"	UNC	13	0.142	14,910	41	4,920	82	9,841
5/8"	UNC	11	0.226	23,730	82	7,831	163	15,662
3/4"	UNC	10	0.334	35,070	145	11,573	289	23,146
7/8"	UNC	9	0.462	48,510	233	16,008	467	32,017
1"	UNC	8	0.606	63,630	350	20,998	700	41,996
1.1/8"	UN8	8	0.790	82,950	513	27,374	1,027	54,747
1.1/4"	UN8	8	1.000	105,000	722	34,650	1,444	69,300
1.3/8"	UN8	8	1.23	129,150	977	42,620	1,953	85,239
1.1/2"	UN8	8	1.49	156,660	1,292	51,698	2,585	103,396
1.5/8"	UN8	8	1.78	186,900	1,670	61,677	3,341	123,354
1.3/4"	UN8	8	2.08	218,400	2,102	72,072	4,204	144,144
1.7/8"	UN8	8	2.41	253,050	2,610	83,507	5,219	167,013
2"	UN8	8	2.77	290,850	3,199	95,981	6,399	191,961
2.1/4"	UN8	8	3.56	373,800	4,626	123,354	9,252	246,708
2.1/2"	UN8	8	4.44	466,200	6,410	153,846	12,821	307,692
2.3/4"	UN8	8	5.43	515,850	7,802	170,231	15,604	340,461
3"	UN8	8	6.51	618,450	10,204	204,089	20,409	408,177
3.1/4"	UN8	8	7.69	730,550	13,059	241,082	26,117	482,163
3.1/2"	UN8	8	8.96	851,200	16,386	280,896	32,771	561,792
3.3/4"	UN8	8	10.34	982,300	20,260	324,159	40,520	648,318
4"	UN8	8	11.81	1,121,950	24,683	370,244	49,366	740,487

Displayed values for Minimum Yield Load are derived from Stress Area and Yield Strength.

Values given for Bolt Preloads are for 33% and 66% of Minimum Yield Load respectively.

Values displayed for Tightening Torques are given for guidance only and are derived using a Torque Coefficient of 0.20 (lightly oiled)

For flanges where gaskets are employed users should consult with the gasket manufacturer to obtain compatible tightening torques.

Installation guidance for Stud Bolts and Hex Head Bolts

MECHANICAL PROPERTIES - B16

High Temperature

ASTM A 193/A 193M

TENSIONING & TIGHTENING TORQUES								
Stud Bolt Properties				For Bolt Preload of 33% of Minimum Yield		For Bolt Preload of 66% of Minimum Yield		
Nominal Size	Thread	TPI	Stress Area	Minimum Yield Load	Tightening Torque	Bolt Preload (Bolt Tension)	Tightening Torque	Bolt Preload (Bolt Tension)
Inches			in ²	lbf	ft.lbs	lbf	ft.lbs	lbf
3/8"	UNC	16	0.0775	8,138	17	2,685	34	5,371
1/2"	UNC	13	0.142	14,910	41	4,920	82	9,841
5/8"	UNC	11	0.226	23,730	82	7,831	163	15,662
3/4"	UNC	10	0.334	35,070	145	11,573	289	23,146
7/8"	UNC	9	0.462	48,510	233	16,008	467	32,017
1"	UNC	8	0.606	63,630	350	20,998	700	41,996
1.1/8"	UN8	8	0.790	82,950	513	27,374	1,027	54,747
1.1/4"	UN8	8	1.000	105,000	722	34,650	1,444	69,300
1.3/8"	UN8	8	1.23	129,150	977	42,620	1,953	85,239
1.1/2"	UN8	8	1.49	156,660	1,292	51,698	2,585	103,396
1.5/8"	UN8	8	1.78	186,900	1,670	61,677	3,341	123,354
1.3/4"	UN8	8	2.08	218,400	2,102	72,072	4,204	144,144
1.7/8"	UN8	8	2.41	253,050	2,610	83,507	5,219	167,013
2"	UN8	8	2.77	290,850	3,199	95,981	6,399	191,961
2.1/4"	UN8	8	3.56	373,800	4,626	123,354	9,252	246,708
2.1/2"	UN8	8	4.44	466,200	6,410	153,846	12,821	307,692
2.3/4"	UN8	8	5.43	515,850	7,802	170,231	15,604	340,461
3"	UN8	8	6.51	618,450	10,204	204,089	20,409	408,177
3.1/4"	UN8	8	7.69	730,550	13,059	241,082	26,117	482,163
3.1/2"	UN8	8	8.96	851,200	16,386	280,896	32,771	561,792
3.3/4"	UN8	8	10.34	982,300	20,260	324,159	40,520	648,318
4"	UN8	8	11.81	1,121,950	24,683	370,244	49,366	740,487

Displayed values for Minimum Yield Load are derived from Stress Area and Yield Strength.

Values given for Bolt Preloads are for 33% and 66% of Minimum Yield Load respectively.

Values displayed for Tightening Torques are given for guidance only and are derived using a Torque Coefficient of 0.20 (lightly oiled)

For flanges where gaskets are employed users should consult with the gasket manufacturer to obtain compatible tightening torques.

Installation guidance for Stud Bolts and Hex Head Bolts

MECHANICAL PROPERTIES - L7, L7A, L7B, L7C, L70, L71, L72 & L73

For Low Temperature Service

ASTM A 320 / A 320M

BOLT TENSION AND TIGHTENING TORQUES								
Stud Bolt Properties				For Bolt Preload of 33% of Minimum Yield		For Bolt Preload of 66% of Minimum Yield		
Nominal Size	Thread	TPI	Stress Area	Minimum Yield Load	Tightening Torque	Bolt Preload (Bolt Tension)	Tightening Torque	Bolt Preload (Bolt Tension)
Inches			in ²	lbf	ft.lbs	lbf	ft.lbs	lbf
3/8"	UNC	16	0.0775	8,138	17	2,685	34	5,371
1/2"	UNC	13	0.142	14,910	41	4,920	82	9,841
5/8"	UNC	11	0.226	23,730	82	7,831	163	15,662
3/4"	UNC	10	0.334	35,070	145	11,573	289	23,146
7/8"	UNC	9	0.462	48,510	233	16,008	467	32,017
1"	UNC	8	0.606	63,630	350	20,998	700	41,996
1.1/8"	UN8	8	0.790	82,950	513	27,374	1,027	54,747
1.1/4"	UN8	8	1.000	105,000	722	34,650	1,444	69,300
1.3/8"	UN8	8	1.23	129,150	977	42,620	1,953	85,239
1.1/2"	UN8	8	1.49	156,660	1,292	51,698	2,585	103,396
1.5/8"	UN8	8	1.78	186,900	1,670	61,677	3,341	123,354
1.3/4"	UN8	8	2.08	218,400	2,102	72,072	4,204	144,144
1.7/8"	UN8	8	2.41	253,050	2,610	83,507	5,219	167,013
2"	UN8	8	2.77	290,850	3,199	95,981	6,399	191,961
2.1/4"	UN8	8	3.56	373,800	4,626	123,354	9,252	246,708
2.1/2"	UN8	8	4.44	466,200	6,410	153,846	12,821	307,692
2.3/4"	UN8	8	5.43					
3"	UN8	8	6.51					
3.1/4"	UN8	8	7.69					
3.1/2"	UN8	8	8.96					
3.3/4"	UN8	8	10.34					
4"	UN8	8	11.81					

Not listed in ASTM A 320/A 320M

Displayed values for Minimum Yield Load are derived from Stress Area and Yield Strength.

Values given for Bolt Preloads are for 33% and 66% of Minimum Yield Load respectively.

Values displayed for Tightening Torques are given for guidance only and are derived using a Torque Coefficient of 0.20 (lightly oiled)

For flanges where gaskets are employed users should consult with the gasket manufacturer to obtain compatible tightening torques.

Diameters over 2 1/2" are uncommon and conforming Heat Numbers may not be available

Installation guidance for Stud Bolts and Hex Head Bolts

MECHANICAL PROPERTIES - L7M

For Low Temperature Service

ASTM A 320 / A 320M

BOLT TENSION AND TIGHTENING TORQUES									
Stud Bolt Properties				For Bolt Preload of 33% of Minimum Yield			For Bolt Preload of 66% of Minimum Yield		
Nominal Size	Thread	TPI	Stress Area	Minimum Yield Strength (0.2% offset)	Minimum Yield	Tightening Torque	Bolt Preload (Bolt Tension)	Tightening Torque	Bolt Preload (Bolt Tension)
Inches			in²	lbf/in²	lbf	ft.lbs	lbf	ft.lbs	lbf
3/8"	UNC	16	0.0775	80,000	6,200	13	2,046	26	4,092
1/2"	UNC	13	0.142	80,000	11,360	31	3,749	62	7,498
5/8"	UNC	11	0.226	80,000	18,080	62	5,966	124	11,933
3/4"	UNC	10	0.334	80,000	26,720	110	8,818	220	17,635
7/8"	UNC	9	0.462	80,000	36,960	178	12,197	356	24,394
1"	UNC	8	0.606	80,000	48,480	267	15,998	533	31,997
1.1/8"	UN8	8	0.790	80,000	63,200	391	20,856	782	41,712
1.1/4"	UN8	8	1.000	80,000	80,000	550	26,400	1,100	52,800
1.3/8"	UN8	8	1.23	80,000	98,400	744	32,472	1,488	64,944
1.1/2"	UN8	8	1.49	80,000	119,360	985	39,389	1,969	78,778
1.5/8"	UN8	8	1.78	80,000	142,400	1,273	46,992	2,545	93,984
1.3/4"	UN8	8	2.08	80,000	166,400	1,602	54,912	3,203	109,824
1.7/8"	UN8	8	2.41	80,000	192,800	1,988	63,624	3,977	127,248
2"	UN8	8	2.77	80,000	221,600	2,438	73,128	4,875	146,256
2.1/4"	UN8	8	3.56	80,000	284,800	3,524	93,984	7,049	187,968
2.1/2"	UN8	8	4.44	80,000	355,200	4,884	117,216	9,768	234,432
2.3/4"	UN8	8	5.43						
3"	UN8	8	6.51						
3.1/4"	UN8	8	7.69						
3.1/2"	UN8	8	8.96						
3.3/4"	UN8	8	10.34						
4"	UN8	8	11.81						

Not listed in ASTM A 320/A 320M

Displayed values for Mnimum Yield Load are derived from Stress Area and Yield Strength.
 Values given for Bolt Preloads are for 33% and 66% of Minimum Yield Load respectively.
 Values displayed for Tightening Torques are given for guidance only and are derived using a Torque Coefficient of 0.20 (lightly oiled)
 For flanges where gaskets are employed users should consult with the gasket manufacturer to obtain compatible tightening torques.
 Diameters over 2 1/2" are uncommon and conforming Heat Numbers may not be available

Installation guidance for Stud Bolts and Hex Head Bolts

MECHANICAL PROPERTIES - Class 1 - B8, B8M, B8C, B8P, B8F, B8T, B8LN, & B8MLN
Low Temperature Service
ASTM A 320 / A 320M

BOLT TENSION AND TIGHTENING TORQUES								
Stud Bolt Properties				For Bolt Preload of 33% of Minimum Yield		For Bolt Preload of 66% of Minimum Yield		
Nominal Size	Thread	TPI	Stress Area	Minimum Yield Load	Tightening Torque	Bolt Preload (Bolt Tension)	Tightening Torque	Bolt Preload (Bolt Tension)
Inches			in ²	lbf	ft.lbs	lbf	ft.lbs	lbf
3/8"	UNC	16	0.0775	2,325	4.8	767	10	1,535
1/2"	UNC	13	0.142	4,260	12	1,406	23	2,812
5/8"	UNC	11	0.226	6,780	23	2,237	47	4,475
3/4"	UNC	10	0.334	10,020	41	3,307	83	6,613
7/8"	UNC	9	0.462	13,860	67	4,574	133	9,148
1"	UNC	8	0.606	18,180	100	5,999	200	11,999
1.1/8"	UN8	8	0.790	23,700	147	7,821	293	15,642
1.1/4"	UN8	8	1.000	30,000	206	9,900	413	19,800
1.3/8"	UN8	8	1.23	36,900	279	12,177	558	24,354
1.1/2"	UN8	8	1.49	44,760	369	14,771	739	29,542
1.5/8"	UN8	8	1.78	53,400	477	17,622	955	35,244
1.3/4"	UN8	8	2.08	62,400	601	20,592	1,201	41,184
1.7/8"	UN8	8	2.41	72,300	746	23,859	1,491	47,718
2"	UN8	8	2.77	83,100	914	27,423	1,828	54,846
2.1/4"	UN8	8	3.56	106,800	1,322	35,244	2,643	70,488
2.1/2"	UN8	8	4.44	133,200	1,832	43,956	3,663	87,912
2.3/4"	UN8	8	5.43	162,900	2,464	53,757	4,928	107,514
3"	UN8	8	6.51	195,300	3,222	64,449	6,445	128,898
3.1/4"	UN8	8	7.69	230,700	4,124	76,131	8,248	152,262
3.1/2"	UN8	8	8.96	268,800	5,174	88,704	10,349	177,408
3.3/4"	UN8	8	10.34	310,200	6,398	102,366	12,796	204,732
4"	UN8	8	11.81	354,300	7,795	116,919	15,589	233,838

Displayed values for Minimum Yield Load are derived from Stress Area and Yield Strength.

Values given for Bolt Preloads are for 33% and 66% of Minimum Yield Load respectively.

Values displayed for Tightening Torques are given for guidance only and are derived using a Torque Coefficient of 0.20 (lightly oiled)

For flanges where gaskets are employed users should consult with the gasket manufacturer to obtain compatible tightening torques.

Installation guidance for Stud Bolts and Hex Head Bolts

MECHANICAL PROPERTIES -Class 2 - B8M

Low & High Temperature Service

ASTM A 320 / A 320M & ASTM A 193 / A193M

BOLT TENSION AND TIGHTENING TORQUES									
Stud Bolt Properties				For Bolt Preload of 33% of Minimum Yield			For Bolt Preload of 66% of Minimum Yield		
Nominal Size	Thread	TPI	Stress Area	Minimum Yield Strength (0.2% offset)	Minimum Yield	Tightening Torque	Bolt Preload (Bolt Tension)	Tightening Torque	Bolt Preload (Bolt Tension)
Inches			in²	lbf/in²	lbf	ft.lbs	lbf	ft.lbs	lbf
3/8"	UNC	16	0.0775	95,000	7,363	15	2,430	30	4,859
1/2"	UNC	13	0.142	95,000	13,490	37	4,452	74	8,903
5/8"	UNC	11	0.226	95,000	21,470	74	7,085	148	14,170
3/4"	UNC	10	0.334	95,000	31,730	131	10,471	262	20,942
7/8"	UNC	9	0.462	80,000	36,960	178	12,197	356	24,394
1"	UNC	8	0.606	80,000	48,480	267	15,998	533	31,997
1.1/8"	UN8	8	0.790	65,000	51,350	318	16,946	635	33,891
1.1/4"	UN8	8	1.000	65,000	65,000	447	21,450	894	42,900
1.3/8"	UN8	8	1.23	50,000	61,500	465	20,295	930	40,590
1.1/2"	UN8	8	1.49	50,000	74,600	615	24,618	1,231	49,236
1.5/8"	UN8	8	1.78						
1.3/4"	UN8	8	2.08						
1.7/8"	UN8	8	2.41						
2"	UN8	8	2.77						
2.1/4"	UN8	8	3.56						
2.1/2"	UN8	8	4.44						
2.3/4"	UN8	8	5.43						
3"	UN8	8	6.51						
3.1/4"	UN8	8	7.69						
3.1/2"	UN8	8	8.96						
3.3/4"	UN8	8	10.34						

Not listed in ASTM A 320/A 320M or ASTM A 193/A 193M

Displayed values for Minimum Yield Load are derived from Stress Area and Yield Strength.
 Values given for Bolt Preloads are for 33% and 66% of Minimum Yield Load respectively.
 Values displayed for Tightening Torques are given for guidance only and are derived using a Torque Coefficient of 0.20 (lightly oiled)
 For flanges where gaskets are employed users should consult with the gasket manufacturer to obtain compatible tightening torques.
 Austenitic steels in the strain hardened (work hardened) condition may not show uniform properties in sizes over 1.1/2" in diameter.

Installation guidance for Stud Bolts and Hex Head Bolts

MECHANICAL PROPERTIES - Class 2 - B8, B8C, B8P, B8F & B8T

Low & High Temperature Service

ASTM A 320 / A 320M and ASTM A 193 / A 193M

BOLT TENSION AND TIGHTENING TORQUES								
Stud Bolt Properties				For Bolt Preload of 33% of Minimum Yield		For Bolt Preload of 66% of Minimum Yield		
Nominal Size	Thread	TPI	Stress Area	Minimum Yield Load	Tightening Torque	Bolt Preload (Bolt Tension)	Tightening Torque	Bolt Preload (Bolt Tension)
Inches			in ²	lbf	ft.lbs	lbf	ft.lbs	lbf
3/8"	UNC	16	0.0775	7,750	16	2,558	32	5,115
1/2"	UNC	13	0.142	14,200	39	4,686	78	9,372
5/8"	UNC	11	0.226	22,600	78	7,458	155	14,916
3/4"	UNC	10	0.334	33,400	138	11,022	276	22,044
7/8"	UNC	9	0.462	36,960	178	12,197	356	24,394
1"	UNC	8	0.606	48,480	267	15,998	533	31,997
1.1/8"	UN8	8	0.790	51,350	318	16,946	635	33,891
1.1/4"	UN8	8	1.000	65,000	447	21,450	894	42,900
1.3/8"	UN8	8	1.23	61,500	465	20,295	930	40,590
1.1/2"	UN8	8	1.49	74,600	615	24,618	1,231	49,236
1.5/8"	UN8	8	1.78					
1.3/4"	UN8	8	2.08					
1.7/8"	UN8	8	2.41					
2"	UN8	8	2.77					
2.1/4"	UN8	8	3.56					
2.1/2"	UN8	8	4.44					
2.3/4"	UN8	8	5.43					
3"	UN8	8	6.51					
3.1/4"	UN8	8	7.69					
3.1/2"	UN8	8	8.96					
3.3/4"	UN8	8	10.34					

Not listed in ASTM A 320/A 320M

Displayed values for Minimum Yield Load are derived from Stress Area and Yield Strength.

Values given for Bolt Preloads are for 33% and 66% of Minimum Yield Load respectively.

Values displayed for Tightening Torques are given for guidance only and are derived using a Torque Coefficient of 0.20 (lightly oiled)

For flanges where gaskets are employed users should consult with the gasket manufacturer to obtain compatible tightening torques.

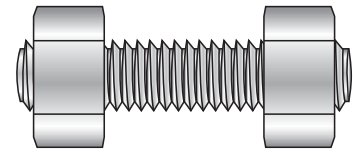

Temperature and Pressure Ratings Carbon Steel Pipe Flanges to ANSI B16.5 (BS 1560)

Operating Temperature			Maximum Working Pressure, kPa by PN (Pressure Numbers)					
			PN20	PN50	PN100	PN150	PN250	PN420
°C								
			(For approximate PSI divide by 7)					
-29	to	38	1960	5110	10210	15320	25530	42550
		50	1920	5010	10020	15020	25040	41730
		100	1770	4640	9280	13910	23190	38650
		150	1580	4520	9050	13570	22610	37690
		200	1400	4380	8760	13150	21910	36520
		250	1210	4170	8340	12520	20860	34770
		300	1020	3870	7750	11620	19370	32280
		350	840	3700	7390	11090	18480	30800
		375	740	3650	7290	10940	18230	30390
		400	650	3450	6900	10350	17250	28750
		425	560	2880	5750	8630	14380	23960
		450	470	2000	4010	6010	10020	16690
		475	370	1350	2710	4060	6770	11290
		500	280	880	1760	2540	4400	7330
		525	190	520	1040	1550	2590	4320
		540	130	330	650	980	1630	2720

- Note:**
1. Forges flanges to ASTM A105 are not recommended for prolonged use above 427°C.
 2. Forged flanges to ASTM A350-LF2 are not to be used above 343°C.
 3. Flanges above DN 600 are not included in ANSI B16.5 and the class designations in these large diameters do not imply specific temperature/pressure ratings.

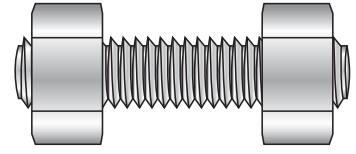

**Bolting Requirement for Raised Face Flanges,
Sizes DN15 to 600 conforming to ANSI B16.5 and DN 750 & 900 to BS 3293**

Nominal Flange Size		PN20 (Class 150)				PN50 (Class 300)			
DN Nominal Diameter	NPS Nominal Pipe Size	Number of Stud Bolts	Diameter of Stud Bolts	Length of Stud Bolts	Length of Hex Bolts L	Number of Stud Bolts	Diameter of Stud Bolts	Length of Stud Bolts	Length of Hex Bolts L
(mm)	(inches)		(inches)	(mm)	(mm)		(inches)	(mm)	(mm)
15	1/2	4	1/2	60	45	4	1/2	65	55
20	3/4	4	1/2	65	50	4	5/8	75	60
25	1	4	1/2	65	55	4	5/8	80	65
32	1.1/4	4	1/2	70	55	4	5/8	80	65
40	1.1/2	4	1/2	70	60	4	3/4	90	75
50	2	4	5/8	80	65	8	5/8	90	75
65	2.1/2	4	5/8	90	75	8	3/4	100	85
80	3	4	5/8	90	75	8	3/4	110	90
90	3.1/2	8	5/8	90	75	8	3/4	110	95
100	4	8	5/8	90	75	8	3/4	110	95
125	5	8	3/4	90	80	8	3/4	120	100
150	6	8	3/4	100	85	12	3/4	125	105
200	8	8	7/8	110	90	12	7/8	140	110
250	10	12	7/8	115	95	16	1	155	130
300	12	12	7/8	120	100	16	1.1/8	170	145
350	14	12	1	130	110	20	1.1/8	175	150
400	16	16	1	135	115	20	1.1/4	190	160
450	18	16	1.1/8	150	125	24	1.1/4	195	170
500	20	20	1.1/8	160	135	24	1.1/4	205	180
600	24	20	1.1/4	175	145	24	1.1/2	230	195
750	30	28	1.1/4	190	160	28	1.3/4	290	250
900	36	32	1.1/2	215	180	32	2	325	280

- Note:**
1. Raised Face height of 2mm for PN20 & 50 and 7mm for PN100 and above is included in bolt length.
 2. Studbolt lengths are exclusive of point lengths (length of full thread).
 3. Bolt lengths are rounded to the nearest 5mm.

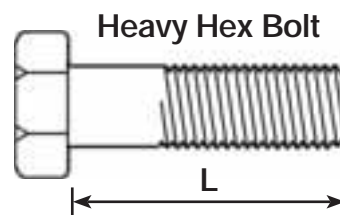
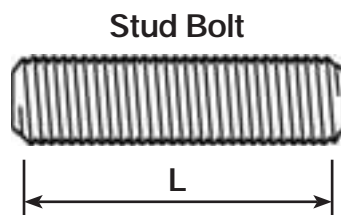

Bolt Diameters are given in inches.

Stud Bolt Lengths (L) are given in millimetres. Stud Bolt lengths do not include the height of points.

Heavy Hex Bolt Lengths (L) are given in millimetres and include the height of point.

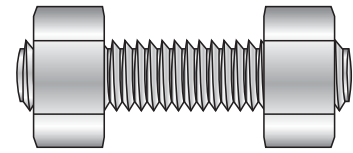

Bolting Requirement for Raised Face Flanges, Sizes DN15 to 600 conforming to ANSI B16.5 and DN750 & 900 to BS 3293

Nominal Flange Size		PN100 (Class 600)			PN150 (Class 900)		
DN Nominal Diameter (mm)	NPS Nominal Pipe Size (inches)	Number of Stud Bolts	Diameter of Stud Bolts (inches)	Length of Stud Bolts (mm)	Number of Stud Bolts	Diameter of Stud Bolts (inches)	Length of Stud Bolts (mm)
15	1/2	4	1/2	80	4	3/4	105
20	3/4	4	5/8	90	4	3/4	115
25	1	4	5/8	90	4	7/8	125
32	1.1/4	4	5/8	100	4	7/8	125
40	1.1/2	4	3/4	105	4	1	140
50	2	8	5/8	105	8	7/8	145
65	2.1/2	8	3/4	120	8	1	160
80	3	8	3/4	125	8	7/8	145
90	3.1/2	8	7/8	140	-	-	-
100	4	8	7/8	145	8	1.1/8	170
125	5	8	1	165	8	1.1/4	190
150	6	12	1	170	12	1.1/8	195
200	8	12	1.1/8	195	12	1.3/8	220
250	10	16	1.1/4	216	16	1.3/8	235
300	12	20	1.1/4	220	20	1.3/8	255
350	14	20	1.3/8	235	20	1.1/2	275
400	16	20	1.1/2	255	20	1.5/8	285
450	18	20	1.5/8	275	20	1.7/8	325
500	20	24	1.5/8	290	20	2	345
600	24	24	1.7/8	330	20	2.1/2	435
750	30	28	2	355	Not listed in BS 3293		
900	36	28	2.1/2	400	Not listed in BS 3293		

- Note:**
1. Raised face height of 2mm for PN20 and 50 and 7mm for PN100 and above is included in bolt length.
 2. Studbolt lengths are exclusive of point lengths (length of full thread).

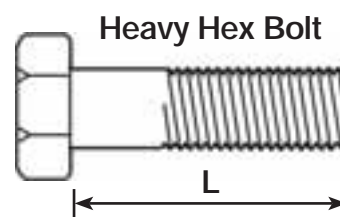
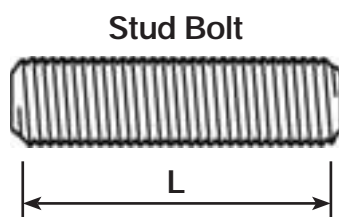

Bolt Diameters are given in inches.

Stud Bolt Lengths (L) are given in millimetres. Stud Bolt lengths do not include the height of points.

Heavy Hex Bolt Lengths (L) are given in millimetres and include the height of point.

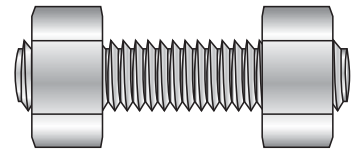

**Bolting Requirements for Raised Face Flanges,
Sizes DN15 to 600 conforming to ANSI B16.5 and DN750 & 900 to BS 3293**

Nominal Flange Size		PN250 (Class 1500)			PN420 (Class 2500)		
DN Nominal Diameter (mm)	NPS Nominal Pipe Size (inches)	Number of Stud Bolts	Diameter of Stud Bolts (inches)	Length of Stud Bolts (mm)	Number of Stud Bolts	Diameter of Stud Bolts (inches)	Length of Stud Bolts (mm)
15	1/2	4	3/4	105	4	3/4	125
20	3/4	4	3/4	115	4	3/4	125
25	1	4	7/8	125	4	7/8	140
32	1.1/4	4	7/8	125	4	1	150
40	1.1/2	4	1	140	4	1.1/8	170
50	2	8	7/8	145	8	1	175
65	2.1/2	8	1	160	8	1.1/8	195
80	3	8	1.1/8	180	8	1.1/4	220
90	3.1/2	-	-	-	-	-	-
100	4	8	1.1/4	195	8	1.1/2	255
125	5	8	1.1/2	250	8	1.3/4	300
150	6	12	1.3/8	260	8	2	345
200	8	12	1.5/8	290	12	2	380
250	10	12	1.7/8	335	12	2.1/2	485
300	12	16	2	375	12	2.3/4	540
350	14	16	2.1/4	405	-	-	-
400	16	16	2.1/2	445	-	-	-
450	18	16	2.3/4	495	-	-	-
500	20	16	3	540	-	-	-
600	24	16	3.1/2	615	-	-	-
750	30	Not listed in BS 3293			Not listed in BS 3293		
900	36	Not listed in BS 3293			Not listed in BS 3293		

- Note:**
1. Raised face height of 2mm for PN20 and 50 and 7mm for PN100 and above is included in bolt length.
 2. Studbolt lengths are exclusive of point lengths (length of full thread).

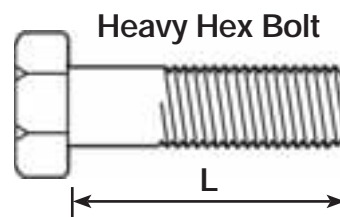
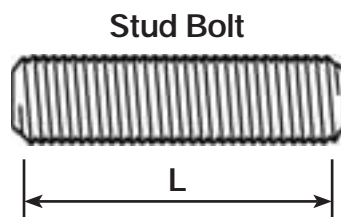

Bolt Diameters are given in inches.

Stud Bolt Lengths (L) are given in millimetres. Stud Bolt lengths do not include the height of points.

Heavy Hex Bolt Lengths (L) are given in millimetres and include the height of point.

A full set of our current conditions is available on request

FIS Delivery

Our company does not pass on the cost of normal freight to customers, providing orders are despatched by our nominated carriers.

Payment/Credits

Our trading terms are 30 days from statement date. Consignment stock is not available.

Returns for credit are subject to prior approval and allocation of an acceptance number, without which our warehouse is directed not to receive them. Receipt of goods in this way does not imply agreement to issue a credit note.

Approval of credit can only be considered if the request for credit in writing is received (within 14 days of receipt of goods) showing the credit acceptance number, original invoice number, date and reason for return.

No freight charges for return of goods shall be accepted unless authorised by Bremick.

Products which have been reworked, specially manufactured or zinc plated cannot be returned.

List Prices

All prices are Industrial List, current at the time of printing and adopted by leading suppliers and distributors. Relevant trade discounts apply. Tax is not included. All care but no responsibility is taken.

Fixed Term Pricing

Some end users request firm (eg, 12 month contract) pricing arrangements. We receive no guarantees in relation to our costs. Increases usually occur without advance notice, resulting from currency fluctuation and in reaction to raw material costs and worldwide demand. Hence we cannot make fixed longterm price undertakings to distributors and do not recommend they do so to end users. However, we can advise anticipated price trends resulting from recent changes in our own costs.

We are unable to commit to a fixed period of prior advice of upcoming price changes (detailed written explanation available on request) but have always worked closely with specialist merchant distributors.

Disclaimer

- This document is published and distributed to provide general guidelines on products.
- Bremick Pty Ltd hereby advise the users of products contained herein to make their own enquiries of individual respective manufacturers in respect of the particular specific applications which those users propose for these products.
- Bremick Pty Ltd takes no responsibility at all for the use or misuse of those products in any way.

This publication is distributed on the terms and understanding that the authors, consultants and the publisher expressly disclaim all and any liability and responsibility to any person, whether a reader of this publications or not, in respect of any thing and or the consequences of any thing done or omitted to be done by any such person in reliance, whether wholly or partially, upon the whole or any part of the contents of this publication. Without limiting the generality of the above, no author, consultant or publisher shall have any responsibility for any act or

omission of any other author, consultant or publisher. All rights reserved. No part of this work that is covered by copyright may be reproduced or copied in any form or by any means (including but not limited to graphic, electronic or mechanical. Including photocopying, recording, and taping, or in information retrieval systems) without the written permission of Bremick Pty Limited, which permission may in the absolute discretion of Bremick Pty Limited be withheld.

Romalpa Clause

1. Notwithstanding anything in these Conditions of Sale contained, expressed or implied or incorporated herein by reference and notwithstanding any rule of law or equity to the contrary and notwithstanding any course of dealing between the Company and the Purchaser, property in goods shall not pass from the Company to the Purchaser unless and until –
 - (a) Such goods have been delivered in accordance with these conditions and
 - (b) The Purchaser shall have made payment in full for such goods ("the goods") and
 - (c) The Purchaser shall have fully discharged all their indebtedness and other liability (if any) of the Purchaser to the Company on whatsoever account. The Purchaser shall, notwithstanding the foregoing, be empowered as the agent of the Company to sell the goods and shall hold the proceeds of such sale upon trust to apply the same, firstly in payment or otherwise discharging the price payable to the Company for such goods and any other costs of carriage or insurance or other costs or expenses borne by the Company in respect thereof; secondly, in paying or otherwise discharging all the other indebtedness or liability (if any) of the Purchaser to the Company on whatsoever account, which is outstanding at the date that the Purchaser receives such proceeds of sale; thirdly, as to any balance, for the Purchaser's own use and benefit. Pending the passing of title to the goods the Company may require the Purchaser to mark the goods as being the property of the Company.

This catalogue has been produced by Bremick Pty Ltd, A.B.N 68 000 496 131. All care was taken in its preparation, however Bremick accepts no responsibility for the accuracy of information it contains. Copyright 2006.